

N-channel 600 V, 0.13 Ω typ., 23 A FDmesh™ II Power MOSFETs
in D²PAK, TO-220FP, TO-220 and TO-247 packages

Datasheet - production data

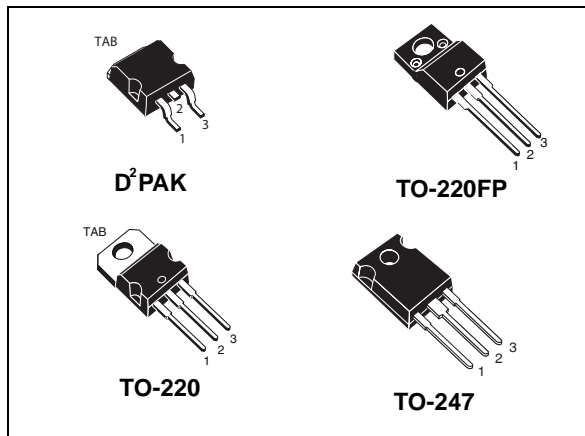
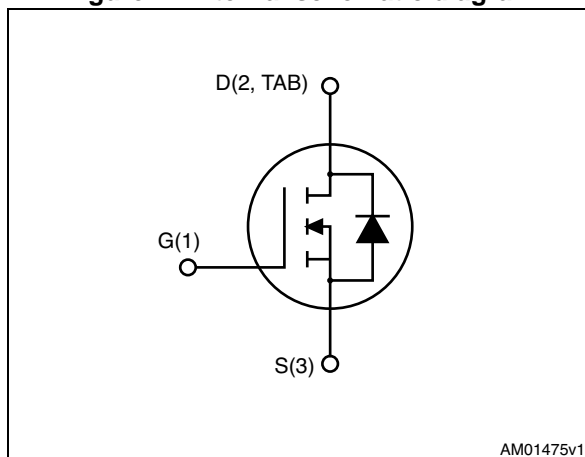

Figure 1. Internal schematic diagram



Features

| Order codes | V_{DS} @ T_J max. | $R_{DS(on)}$ max | I_D |
|-------------|--------------------------|------------------|-------|
| STB28NM60ND | 650 V | 0.150 Ω | 23 A |
| STF28NM60ND | | | |
| STP28NM60ND | | | |
| STW28NM60ND | | | |

- Intrinsic fast-recovery body diode
- 100% avalanche tested
- Low input capacitance and gate charge
- Low gate input resistance
- Extremely high dv/dt and avalanche capabilities

Applications

- Switching applications

Description

These FDmesh™ II Power MOSFETs with intrinsic fast-recovery body diode are produced using the second generation of MDmesh™ technology. Utilizing a new strip-layout vertical structure, these revolutionary devices feature extremely low on-resistance and superior switching performance. They are ideal for bridge topologies and ZVS phase-shift converters.

Table 1. Device summary

| Order codes | Marking | Packages | Packaging |
|-------------|----------|--------------------|---------------|
| STB28NM60ND | 28NM60ND | D ² PAK | Tape and reel |
| STF28NM60ND | | TO-220FP | Tube |
| STP28NM60ND | | TO-220 | |
| STW28NM60ND | | TO-247 | |

Contents

| | | |
|----------|---|-----------|
| 1 | Electrical ratings | 3 |
| 2 | Electrical characteristics | 4 |
| 2.1 | Electrical characteristics (curves) | 6 |
| 3 | Test circuits | 9 |
| 4 | Package mechanical data | 10 |
| 4.1 | D ² PAK, STB28NM60ND | 11 |
| 4.2 | TO-220FP, STF28NM60ND | 13 |
| 4.3 | TO-220, STP28NM60ND | 15 |
| 4.4 | TO-247, STW28NM60ND | 17 |
| 5 | Packing mechanical data | 19 |
| 6 | Revision history | 21 |

1 Electrical ratings

Table 2. Absolute maximum ratings

| Symbol | Parameter | Value | | Unit |
|--------------------------------|--|------------------------------------|---------------------|------|
| | | D ² PAK, TO-220, TO-247 | TO-220FP | |
| V _{DS} | Drain-source voltage | 600 | | V |
| V _{GS} | Gate-source voltage | ±25 | | V |
| I _D | Drain current (continuous) at T _C = 25 °C | 23 | 23 ⁽¹⁾ | A |
| I _D | Drain current (continuous) at T _C = 100 °C | 14.5 | 14.5 ⁽¹⁾ | A |
| I _{DM} ⁽²⁾ | Drain current (pulsed) | 92 | 92(1) | A |
| P _{TOT} | Total dissipation at T _C = 25 °C | 190 | 35 | W |
| dv/dt ⁽³⁾ | Peak diode recovery voltage slope | 40 | | V/ns |
| V _{ISO} | Insulation withstand voltage (RMS) from all three leads to external heat sink (t=1 s; T _C =25 °C) | | 2500 | V |
| T _{stg} | Storage temperature | -55 to 150 | | °C |
| T _J | Max. operating junction temperature | 150 | | °C |

- Limited by maximum junction temperature
- Pulse width limited by safe operating area
- I_{SD} ≤ 23 A, di/dt ≤ 600 A/μs, V_{DD} = 80% V_{(BR)DSS}

Table 3. Thermal data

| Symbol | Parameter | D ² PAK | TO-220FP | TO-220 | TO-247 | Unit |
|-------------------------------------|---|--------------------|----------|--------|--------|------|
| R _{thj-case} | Thermal resistance junction-case max | 0.66 | 3.6 | 0.66 | | °C/W |
| R _{thj-amb} | Thermal resistance junction-ambient max | | 62.5 | | 50 | °C/W |
| R _{thj-pcb} ⁽¹⁾ | Thermal resistance junction-pcb max | 30 | | | | °C/W |

- When mounted on 1inch² FR-4 board, 2 oz Cu

Table 4. Avalanche characteristics

| Symbol | Parameter | Max value | Unit |
|-----------------|--|-----------|------|
| I _{AR} | Avalanche current, repetitive or not-repetitive (pulse width limited by T _J max) | 5 | A |
| E _{AS} | Single pulse avalanche energy (starting T _J = 25 °C, I _D = I _{AS} , V _{DD} = 50 V) | 450 | mJ |

2 Electrical characteristics

($T_{CASE}=25\text{ °C}$ unless otherwise specified).

Table 5. On/off states

| Symbol | Parameter | Test conditions | Value | | | Unit |
|---------------|--|--|-------|------|-----------|---------------|
| | | | Min. | Typ. | Max. | |
| $V_{(BR)DSS}$ | Drain-source breakdown voltage | $I_D = 1\text{ mA}, V_{GS} = 0$ | 600 | | | V |
| $dv/dt^{(1)}$ | Drain source voltage slope | $V_{DD} = 480\text{ V}, I_D = 23\text{ A}, V_{GS} = 10\text{ V}$ | 45 | | | V/ns |
| I_{DSS} | Zero gate voltage drain current ($V_{GS} = 0$) | $V_{DS} = 600\text{ V}$ | | | 1 | μA |
| | | $V_{DS} = 600\text{ V}, T_C = 125\text{ °C}$ | | | 100 | μA |
| I_{GSS} | Gate-body leakage current ($V_{DS} = 0$) | $V_{GS} = \pm 20\text{ V}$ | | | ± 100 | nA |
| $V_{GS(th)}$ | Gate threshold voltage | $V_{DS} = V_{GS}, I_D = 250\text{ }\mu\text{A}$ | 3 | 4 | 5 | V |
| $R_{DS(on)}$ | Static drain-source on resistance | $V_{GS} = 10\text{ V}, I_D = 11.5\text{ A}$ | | 0.13 | 0.15 | Ω |

1. Characteristic value at turn off on inductive load.

Table 6. Dynamic

| Symbol | Parameter | Test conditions | Min. | Typ. | Max. | Unit |
|----------------------------|-------------------------------|--|------|------|------|----------|
| C_{iss} | Input capacitance | $V_{DS} = 100\text{ V}, f = 1\text{ MHz}, V_{GS} = 0$ | - | 2090 | - | pF |
| C_{oss} | Output capacitance | | - | 90 | - | pF |
| C_{riss} | Reverse transfer capacitance | | - | 5.5 | - | pF |
| $C_{oss\text{ eq.}}^{(1)}$ | Equivalent output capacitance | $V_{GS} = 0, V_{DS} = 0\text{ to }480\text{ V}$ | - | 312 | - | pF |
| $t_{d(on)}$ | Turn-on delay time | $V_{DD} = 300\text{ V}, I_D = 11.5\text{ A}, R_G = 4.7\text{ }\Omega, V_{GS} = 10\text{ V}$ (see Figure 18), (see Figure 20) | - | 23.5 | - | ns |
| t_r | Rise time | | - | 21.5 | - | ns |
| $t_{d(off)}$ | Turn-off delay time | | - | 92 | - | ns |
| t_f | Fall time | | - | 27 | - | ns |
| Q_g | Total gate charge | $V_{DD} = 480\text{ V}, I_D = 23\text{ A}, V_{GS} = 10\text{ V},$ (see Figure 10) | - | 62.5 | - | nC |
| Q_{gs} | Gate-source charge | | - | 11 | - | nC |
| Q_{gd} | Gate-drain charge | | - | 38 | - | nC |
| R_g | Gate input resistance | $f = 1\text{ MHz},$ test signal level = 20 mV, $I_D = 0$ | - | 4.7 | - | Ω |

1. $C_{oss\text{ eq.}}$ is defined as a constant equivalent capacitance giving the same charging time as C_{oss} when V_{DS} increases from 0 to 80% V_{DSS}

Table 7. Source drain diode

| Symbol | Parameter | Test conditions | Min. | Typ. | Max. | Unit |
|-----------------|-------------------------------|---|------|------|------|------|
| I_{SD} | Source-drain current | | - | | 23 | A |
| $I_{SDM}^{(1)}$ | Source-drain current (pulsed) | | - | | 92 | A |
| $V_{SD}^{(2)}$ | Forward on voltage | $I_{SD} = 23 \text{ A}, V_{GS} = 0$ | - | | 1.6 | V |
| t_{rr} | Reverse recovery time | $I_{SD} = 23 \text{ A}, V_{DD} = 60 \text{ V}$ $di/dt = 100 \text{ A}/\mu\text{s}$ (see Figure 17) | - | 170 | | ns |
| Q_{rr} | Reverse recovery charge | | - | 1160 | | nC |
| I_{RRM} | Reverse recovery current | | - | 14 | | A |
| t_{rr} | Reverse recovery time | $I_{SD} = 23 \text{ A}, V_{DD} = 60 \text{ V}$ $di/dt = 100 \text{ A}/\mu\text{s},$ $T_J = 150 \text{ }^\circ\text{C}$ (see Figure 17) | - | 237 | | ns |
| Q_{rr} | Reverse recovery charge | | - | 2090 | | nC |
| I_{RRM} | Reverse recovery current | | - | 18 | | A |

1. Pulse width limited by safe operating area
2. Pulsed: Pulse duration = 300 μs , duty cycle 1.5%.

2.1 Electrical characteristics (curves)

Figure 2. Safe operating area for D²PAK and TO-220

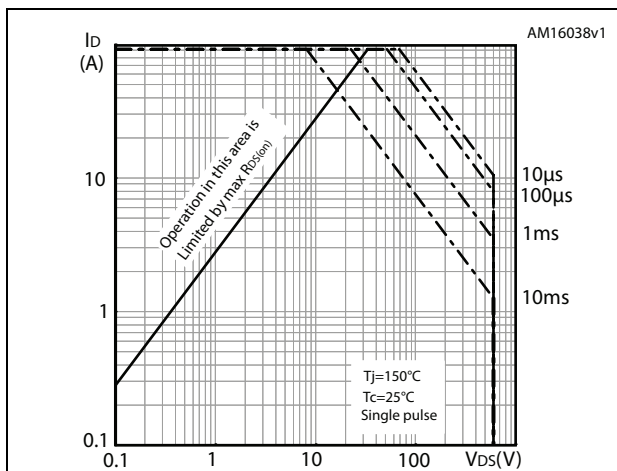

Figure 3. Thermal impedance for D²PAK and TO-220

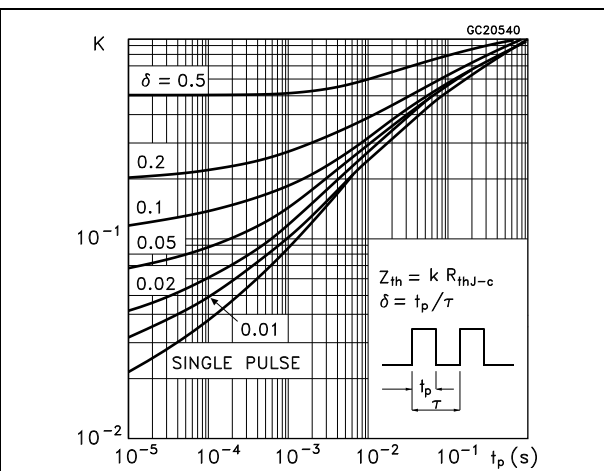

Figure 4. Safe operating area for TO-220FP

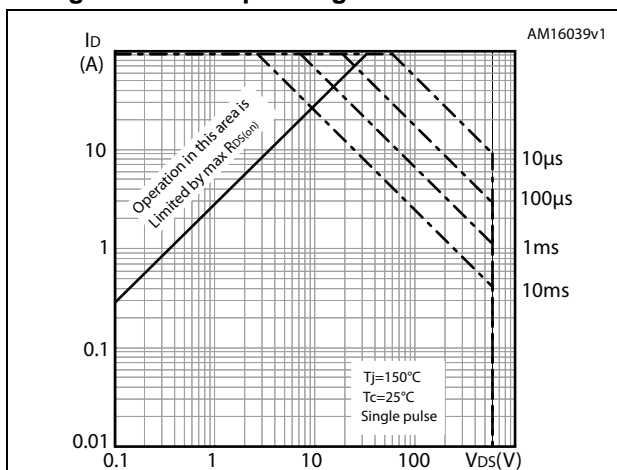

Figure 5. Thermal impedance for TO-220FP

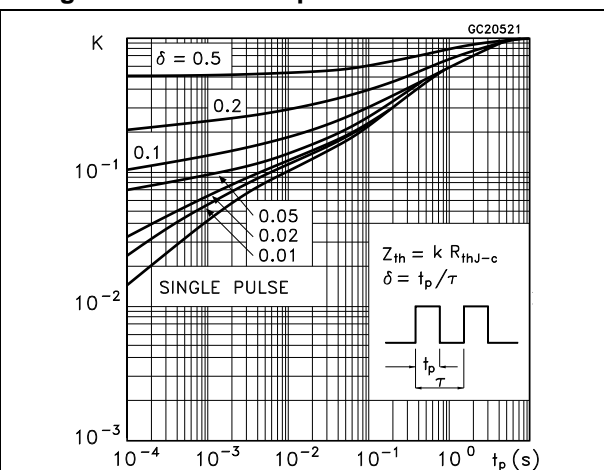

Figure 6. Safe operating area for TO-247

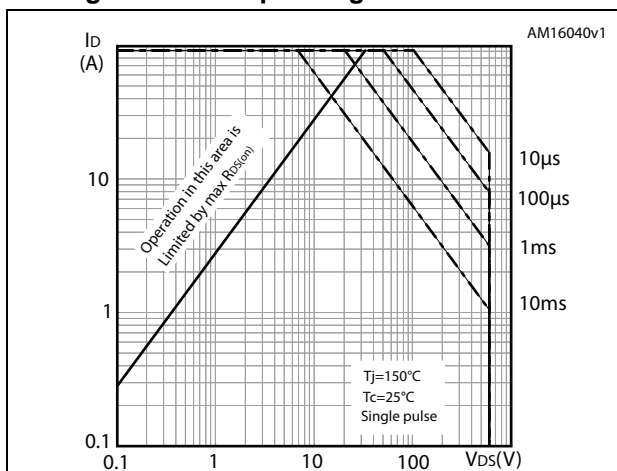

Figure 7. Thermal impedance for TO-247

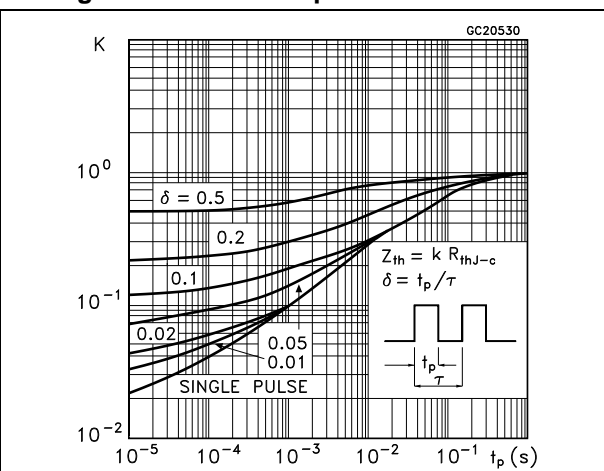

Figure 8. Output characteristics

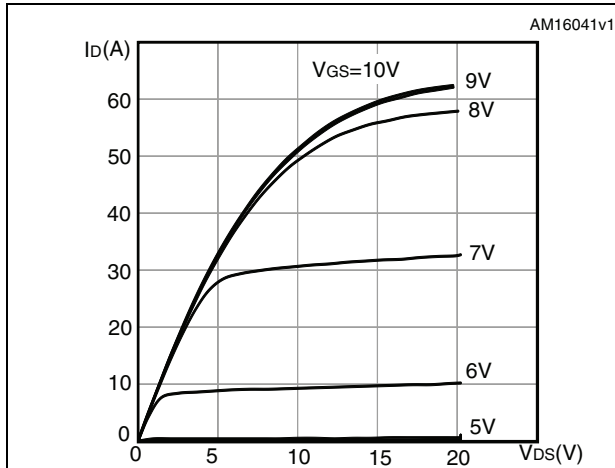

Figure 9. Transfer characteristics

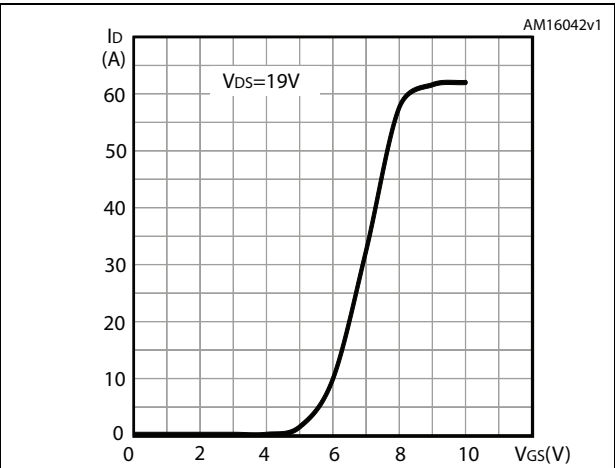

Figure 10. Gate charge vs gate-source voltage

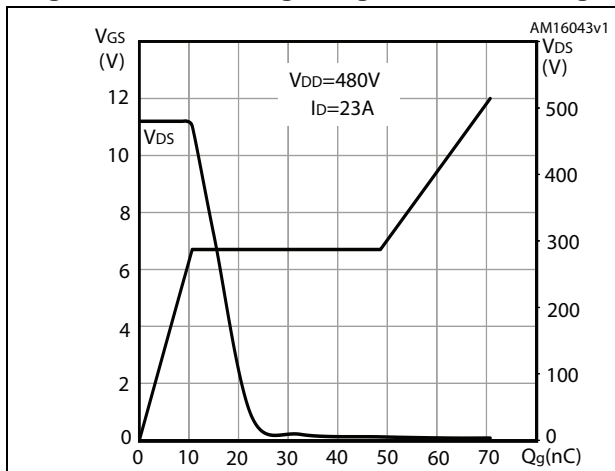

Figure 11. Static drain-source on-resistance

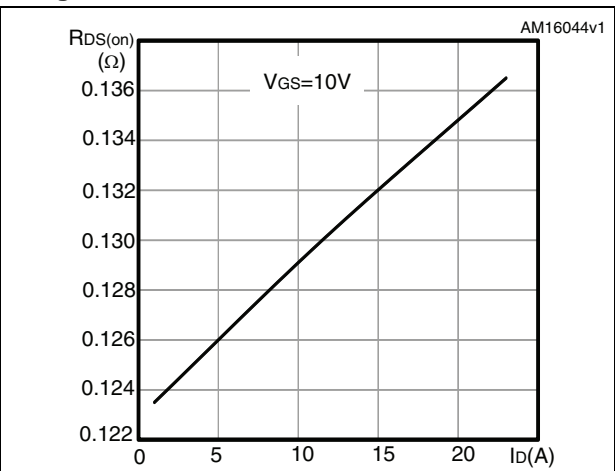

Figure 12. Capacitance variations

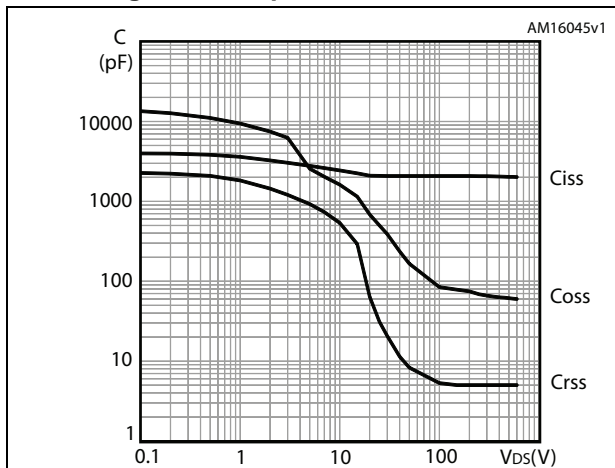

Figure 13. Output capacitance stored energy

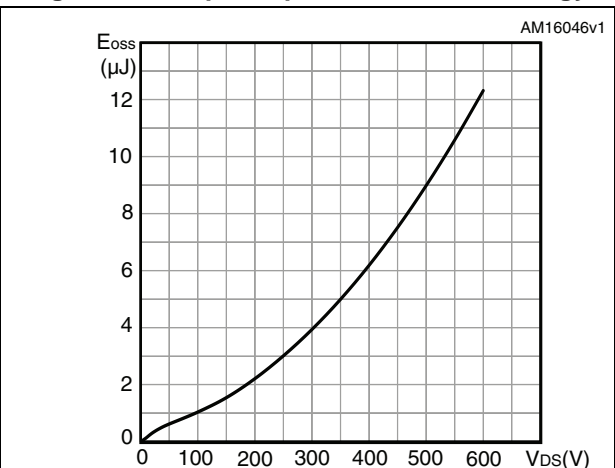

Figure 14. Normalized gate threshold voltage vs temperature

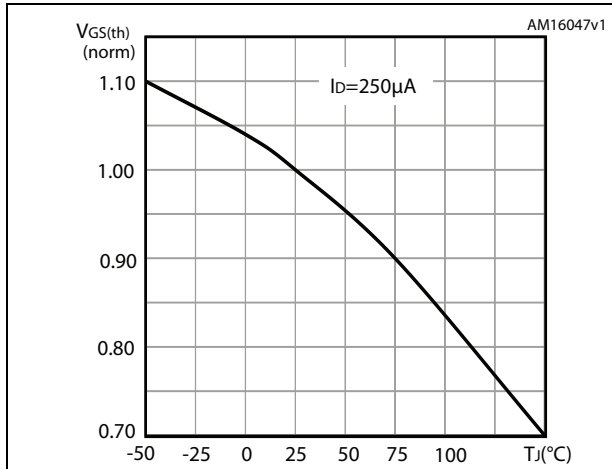

Figure 15. Normalized on-resistance vs temperature

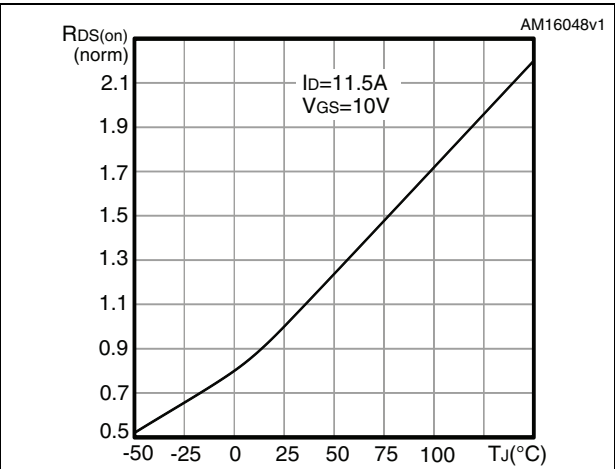

Figure 16. Source-drain diode forward characteristics

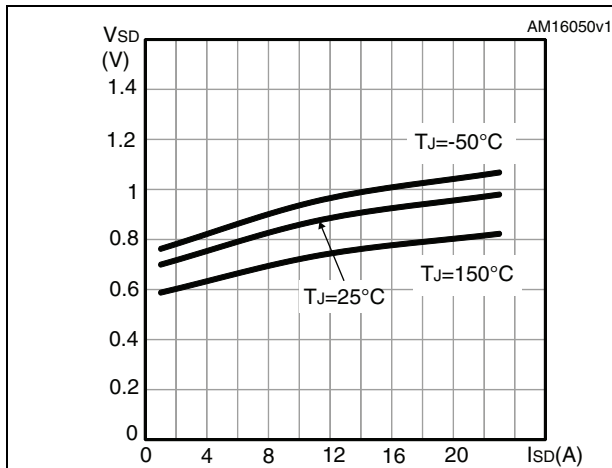
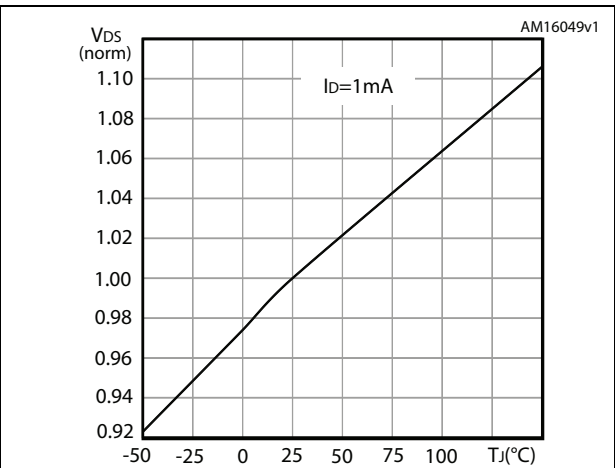
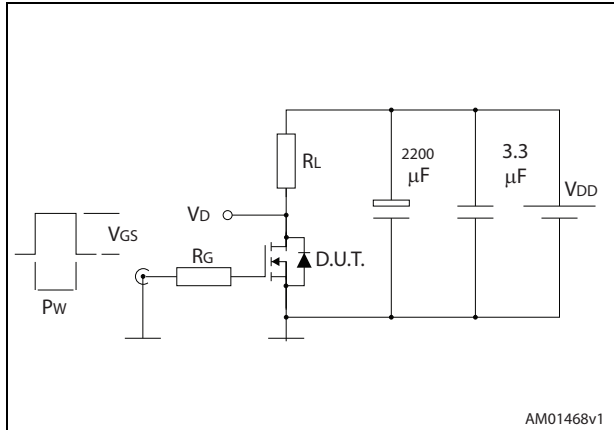

Figure 17. Normalized V_{DS} vs temperature



3 Test circuits

Figure 18. Switching times test circuit for resistive load



AM01468v1

Figure 19. Gate charge test circuit

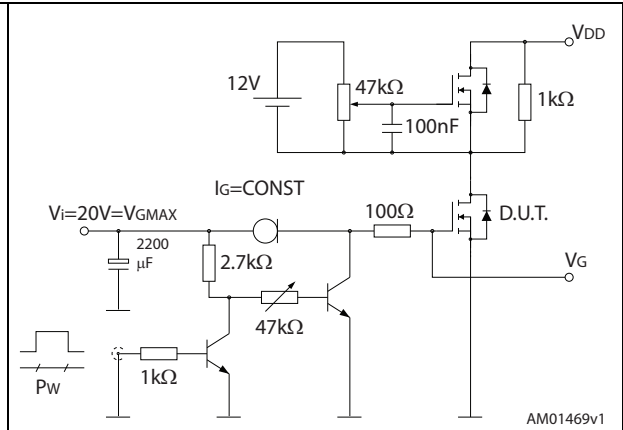

AM01469v1

Figure 20. Test circuit for inductive load switching and diode recovery times

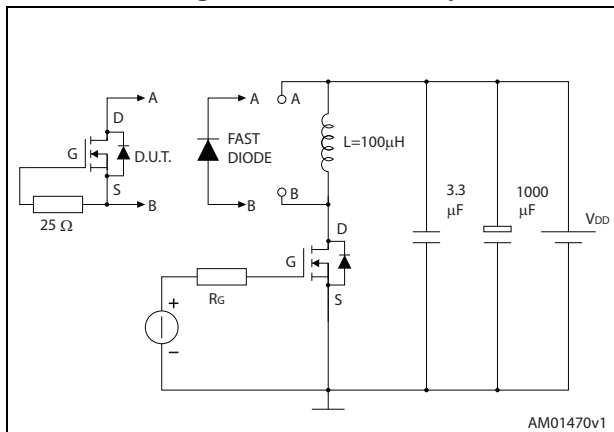

AM01470v1

Figure 21. Unclamped inductive load test circuit

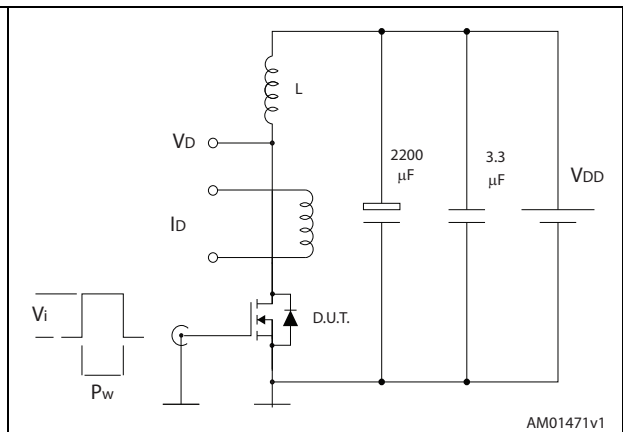

AM01471v1

Figure 22. Unclamped inductive waveform

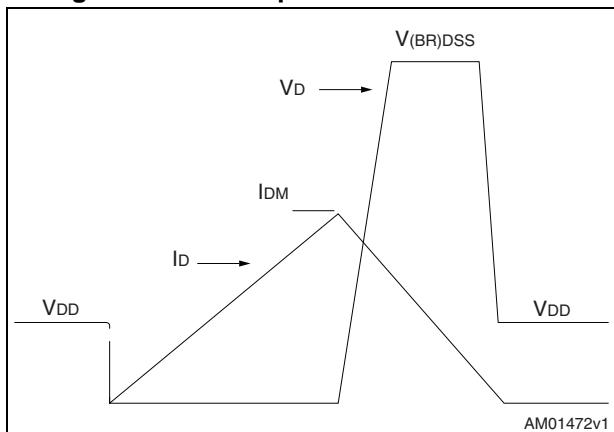

AM01472v1

Figure 23. Switching time waveform

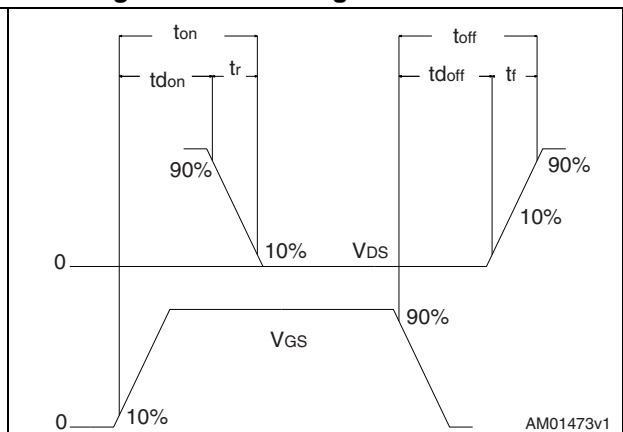

AM01473v1

4 Package mechanical data

In order to meet environmental requirements, ST offers these devices in different grades of ECOPACK[®] packages, depending on their level of environmental compliance. ECOPACK[®] specifications, grade definitions and product status are available at: www.st.com. ECOPACK[®] is an ST trademark.

4.1 D²PAK, STB28NM60ND

Figure 24. D²PAK (TO-263) drawing

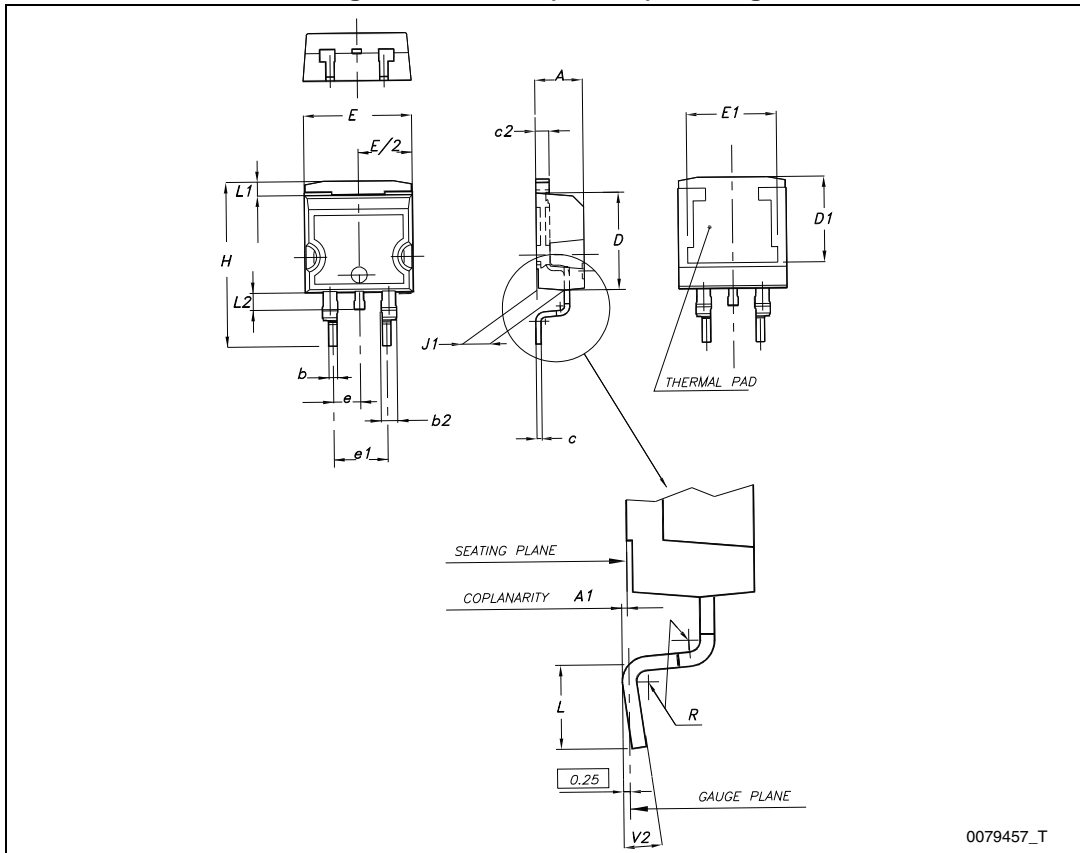
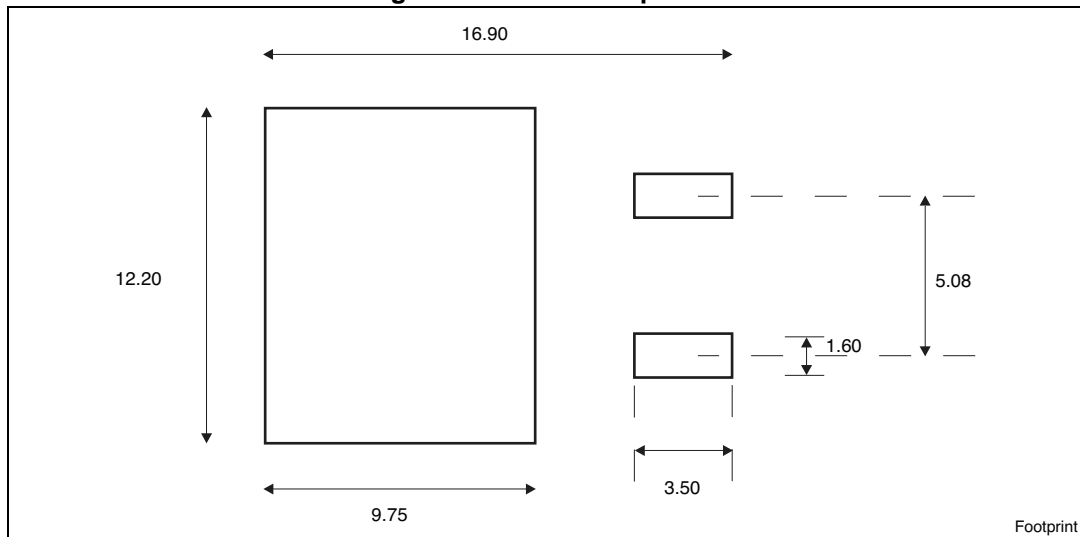

Table 8. D²PAK (TO-263) mechanical data

| Dim. | mm | | |
|------|------|------|-------|
| | Min. | Typ. | Max. |
| A | 4.40 | | 4.60 |
| A1 | 0.03 | | 0.23 |
| b | 0.70 | | 0.93 |
| b2 | 1.14 | | 1.70 |
| c | 0.45 | | 0.60 |
| c2 | 1.23 | | 1.36 |
| D | 8.95 | | 9.35 |
| D1 | 7.50 | | |
| E | 10 | | 10.40 |
| E1 | 8.50 | | |
| e | | 2.54 | |
| e1 | 4.88 | | 5.28 |
| H | 15 | | 15.85 |
| J1 | 2.49 | | 2.69 |
| L | 2.29 | | 2.79 |
| L1 | 1.27 | | 1.40 |
| L2 | 1.30 | | 1.75 |
| R | | 0.4 | |
| V2 | 0° | | 8° |

Figure 25. D²PAK footprint^(a)



a. All dimension are in millimeters

4.2 TO-220FP, STF28NM60ND

Figure 26. TO-220FP drawing

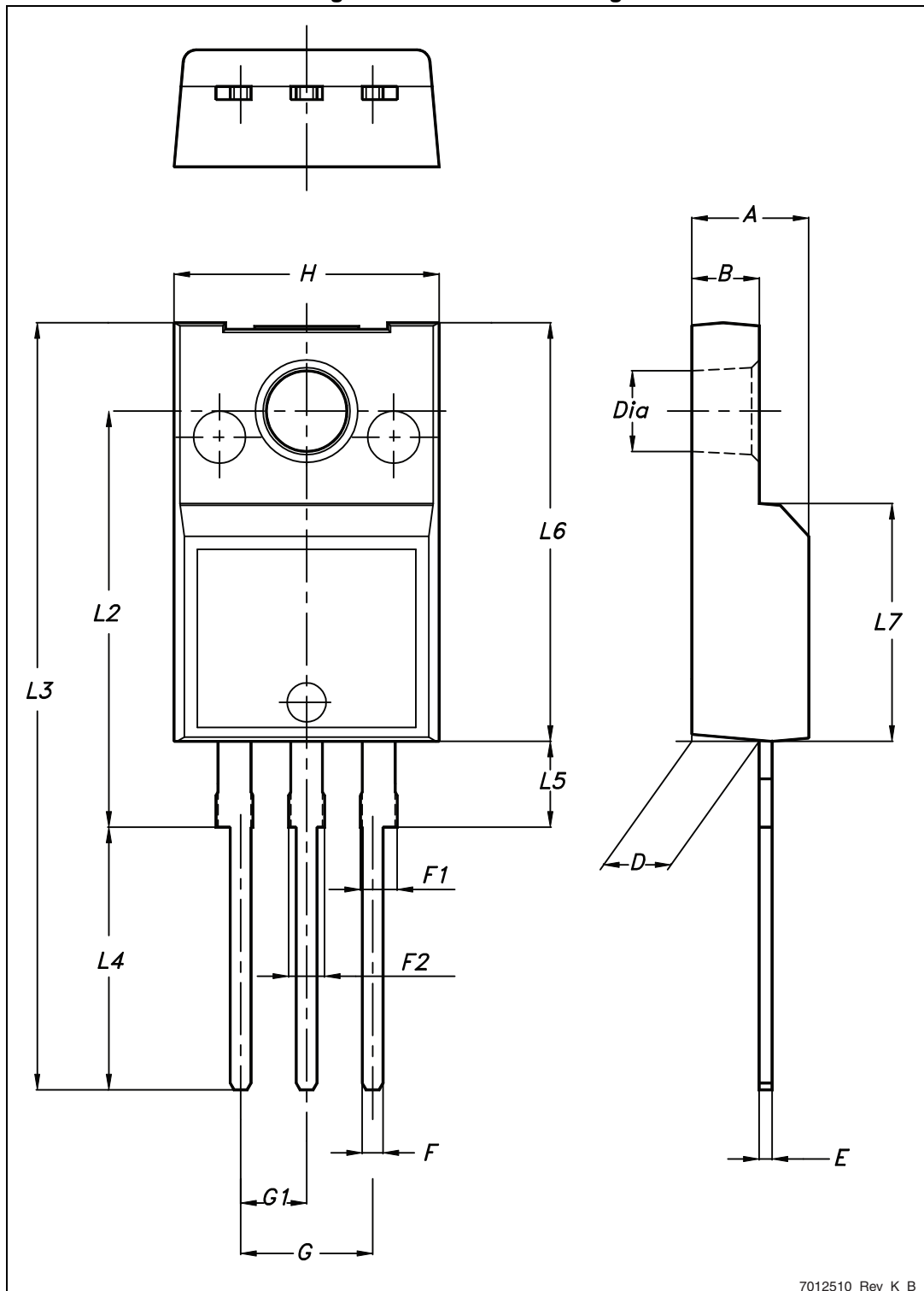

7012510_Rev_K_B

Table 9. TO-220FP mechanical data

| Dim. | mm | | |
|------|------|------|------|
| | Min. | Typ. | Max. |
| A | 4.4 | | 4.6 |
| B | 2.5 | | 2.7 |
| D | 2.5 | | 2.75 |
| E | 0.45 | | 0.7 |
| F | 0.75 | | 1 |
| F1 | 1.15 | | 1.70 |
| F2 | 1.15 | | 1.70 |
| G | 4.95 | | 5.2 |
| G1 | 2.4 | | 2.7 |
| H | 10 | | 10.4 |
| L2 | | 16 | |
| L3 | 28.6 | | 30.6 |
| L4 | 9.8 | | 10.6 |
| L5 | 2.9 | | 3.6 |
| L6 | 15.9 | | 16.4 |
| L7 | 9 | | 9.3 |
| Dia | 3 | | 3.2 |

4.3 TO-220, STP28NM60ND

Figure 27. TO-220 type A drawing

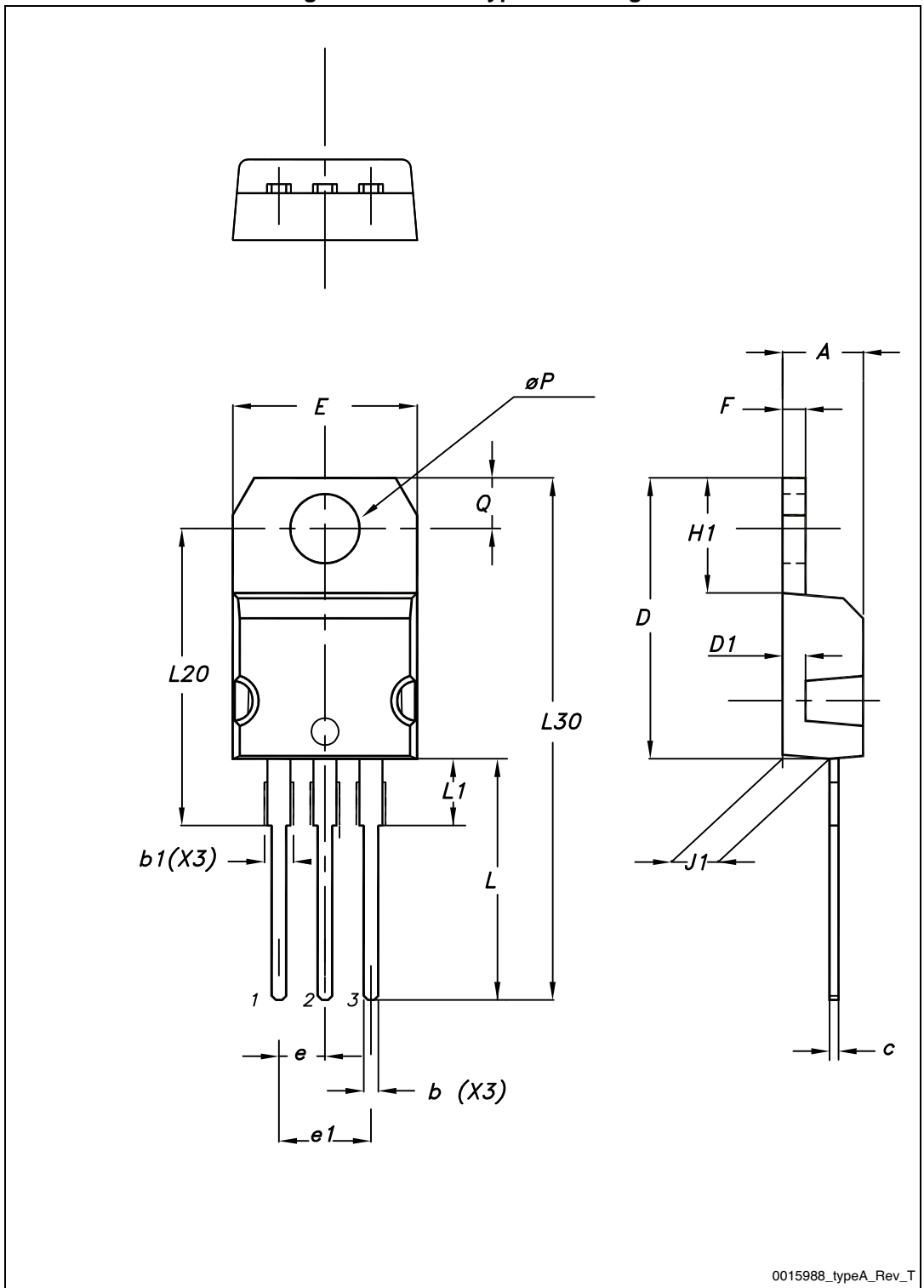

Table 10. TO-220 type A mechanical data

| Dim. | mm | | |
|------|-------|-------|-------|
| | Min. | Typ. | Max. |
| A | 4.40 | | 4.60 |
| b | 0.61 | | 0.88 |
| b1 | 1.14 | | 1.70 |
| c | 0.48 | | 0.70 |
| D | 15.25 | | 15.75 |
| D1 | | 1.27 | |
| E | 10 | | 10.40 |
| e | 2.40 | | 2.70 |
| e1 | 4.95 | | 5.15 |
| F | 1.23 | | 1.32 |
| H1 | 6.20 | | 6.60 |
| J1 | 2.40 | | 2.72 |
| L | 13 | | 14 |
| L1 | 3.50 | | 3.93 |
| L20 | | 16.40 | |
| L30 | | 28.90 | |
| ØP | 3.75 | | 3.85 |
| Q | 2.65 | | 2.95 |

4.4 TO-247, STW28NM60ND

Figure 28. TO-247 drawing

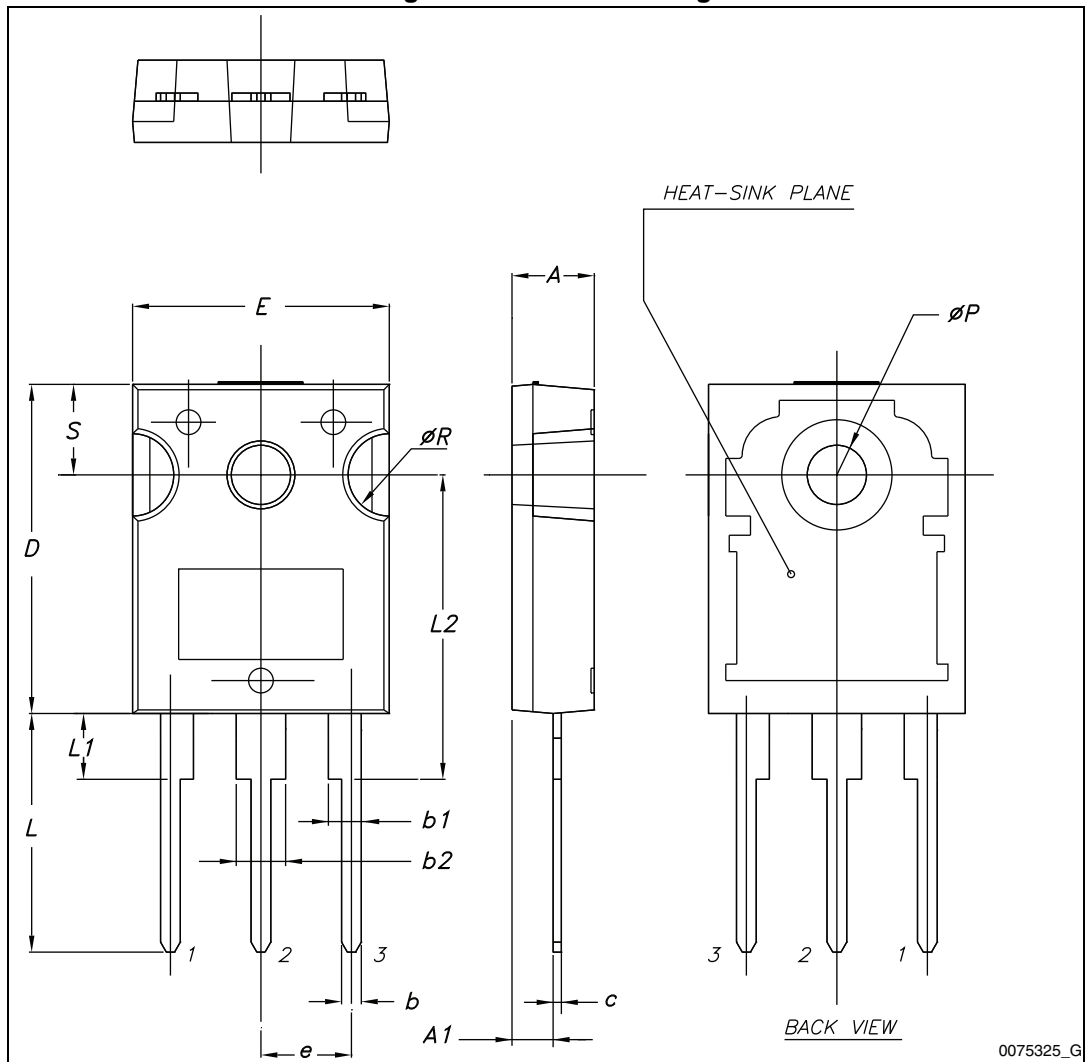

Table 11. TO-247 mechanical data

| Dim. | mm. | | |
|------|-------|-------|-------|
| | Min. | Typ. | Max. |
| A | 4.85 | | 5.15 |
| A1 | 2.20 | | 2.60 |
| b | 1.0 | | 1.40 |
| b1 | 2.0 | | 2.40 |
| b2 | 3.0 | | 3.40 |
| c | 0.40 | | 0.80 |
| D | 19.85 | | 20.15 |
| E | 15.45 | | 15.75 |
| e | 5.30 | 5.45 | 5.60 |
| L | 14.20 | | 14.80 |
| L1 | 3.70 | | 4.30 |
| L2 | | 18.50 | |
| ØP | 3.55 | | 3.65 |
| ØR | 4.50 | | 5.50 |
| S | 5.30 | 5.50 | 5.70 |

5 Packing mechanical data

Figure 29. Tape

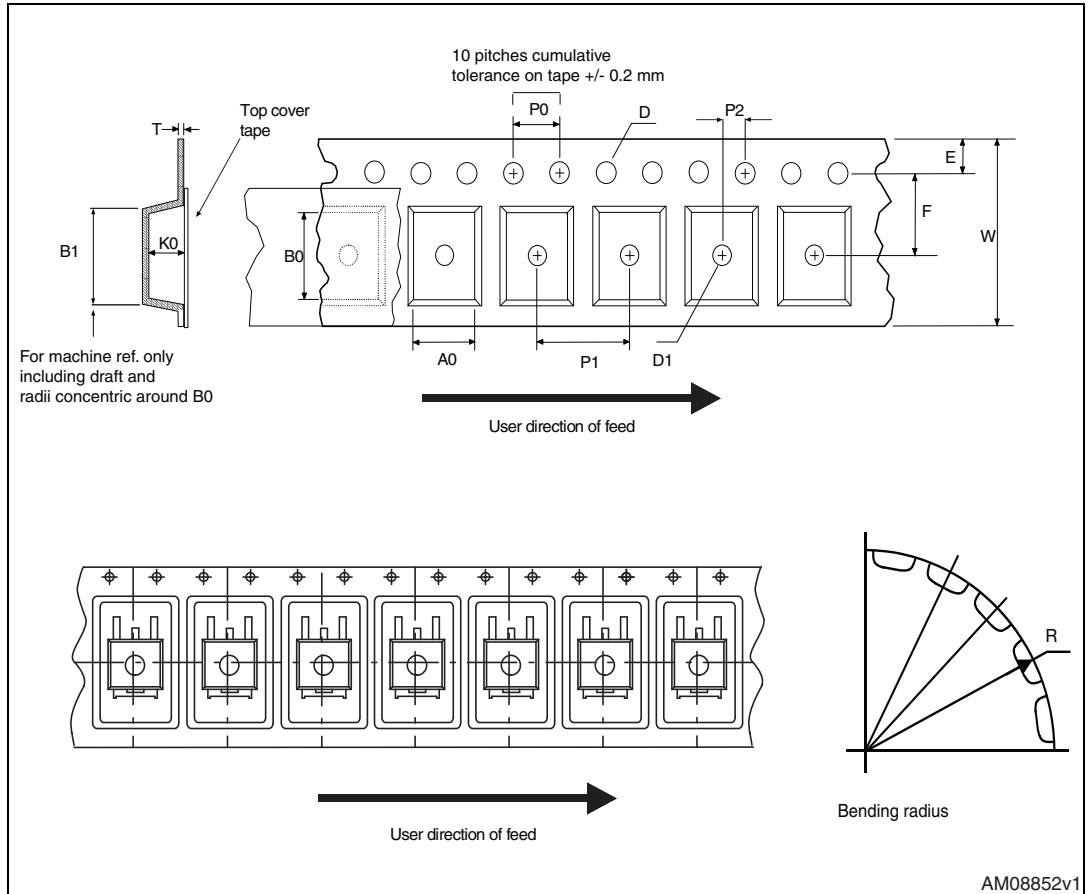
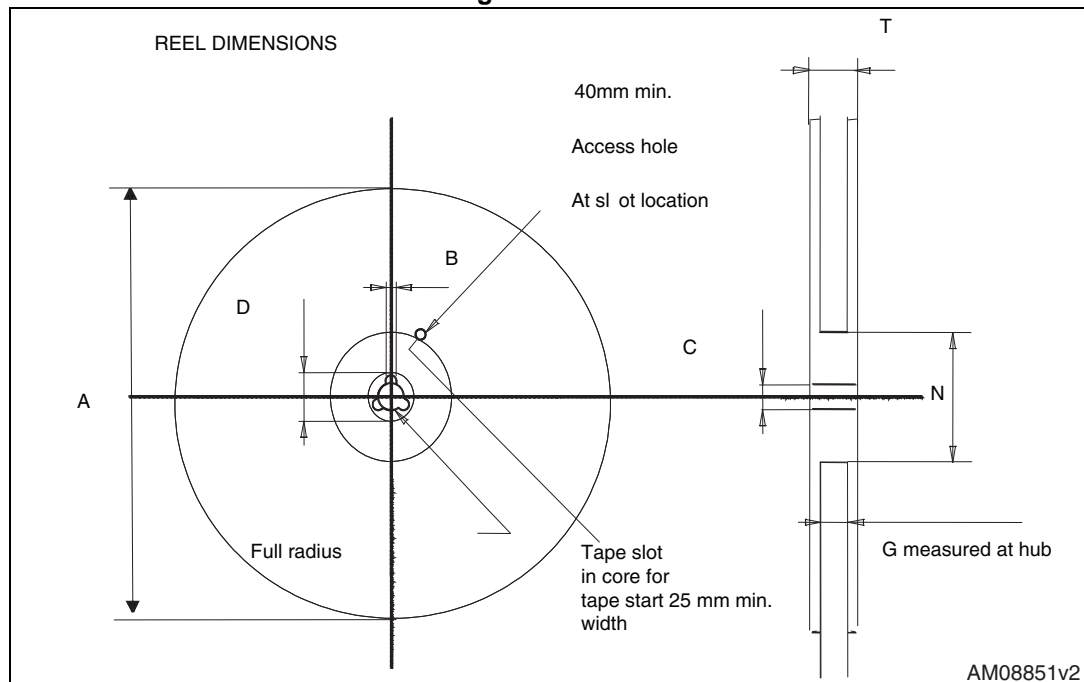

Table 12. D²PAK (TO-263) tape and reel mechanical data

| Tape | | | Reel | | |
|------|------|------|----------|------|------|
| Dim. | mm | | Dim. | mm | |
| | Min. | Max. | | Min. | Max. |
| A0 | 10.5 | 10.7 | A | | 330 |
| B0 | 15.7 | 15.9 | B | 1.5 | |
| D | 1.5 | 1.6 | C | 12.8 | 13.2 |
| D1 | 1.59 | 1.61 | D | 20.2 | |
| E | 1.65 | 1.85 | G | 24.4 | 26.4 |
| F | 11.4 | 11.6 | N | 100 | |
| K0 | 4.8 | 5.0 | T | | 30.4 |
| P0 | 3.9 | 4.1 | | | |
| P1 | 11.9 | 12.1 | Base qty | | 1000 |
| P2 | 1.9 | 2.1 | Bulk qty | | 1000 |
| R | 50 | | | | |
| T | 0.25 | 0.35 | | | |
| W | 23.7 | 24.3 | | | |

Figure 30. Reel



6 Revision history

Table 13. Document revision history

| Date | Revision | Changes |
|-------------|----------|--|
| 15-Apr-2013 | 1 | First release. |
| 25-Nov-2013 | 2 | <ul style="list-style-type: none">– Document status changed from preliminary to production data– Modified: typical values in Table 6 and 7– Added: Section 2.1: Electrical characteristics (curves)– Updated: Table 10 and Figure 27– Minor text changes |
| 05-May-2014 | 3 | <ul style="list-style-type: none">– Modified: E_{AS} value in Table 4– Minor text changes |