

1.5 A max constant current LED driver

Features

- Up to 40 V input voltage
- Less than 0.5 V voltage overhead
- Up to 1.5 A output current
- PWM dimming pin
- Shutdown pin
- LED disconnection diagnostic
- Slope control with external cap

Applications

- LED constant current supplying for varying input voltages
- Low voltage lighting
- Small appliances LED lighting
- Car LED lights

Description

The STCS1A is a BiCMOS constant current source designed to provide a precise constant current starting from a varying input voltage source. The main target is to replace discrete components solution for driving LEDs in low voltage applications such as 5 V, 12 V or 24 V giving benefits in terms of precision, integration and reliability.

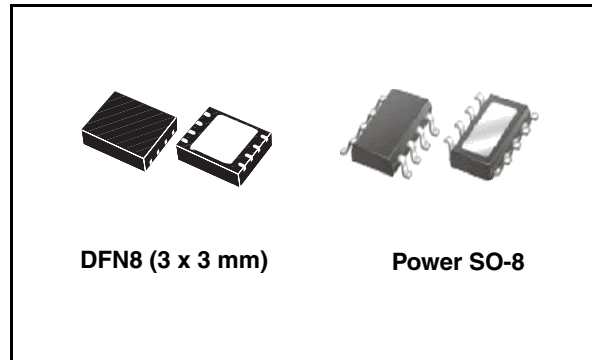

The current is set with external resistor up to 1.5 A with a $\pm 10\%$ precision; a dedicated pin allows implementing PWM dimming. An external capacitor allows setting the slope for the current rise from tens of microseconds to tens of milliseconds allowing reduction of EMI.

An open-drain pin output provides information on load disconnection condition.

Table 1. Device summary

Order codes	Packages	Packaging
STCS1APUR	DFN8 (3 x 3 mm)	3000 parts per reel
STCS1APHR	Power SO-8	2500 parts per reel

Contents

1	Application diagram	3
2	Pin configuration	4
3	Maximum ratings	5
4	Electrical characteristics	6
5	Timing	7
6	Typical performance characteristics	8
7	Detail description	10
	7.1 Current setting	10
	7.2 Enable	10
	7.3 PWM Dimming	10
	7.4 Diagnostic	11
8	Application information	12
	8.1 Reverse polarity protection	12
	8.2 Thermal considerations	12
9	Package mechanical data	14
10	Revision history	18

1 Application diagram

Figure 1. Typical application diagram for 0.5 A LED current

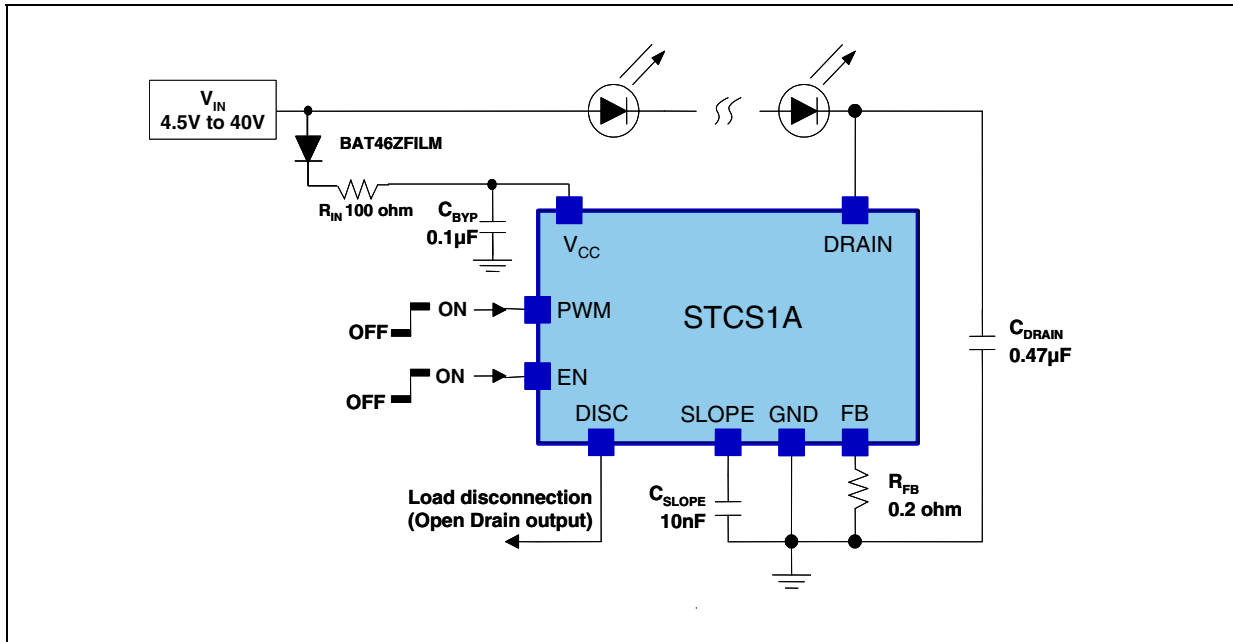

2 Pin configuration

Figure 2. Pin connections (top view)

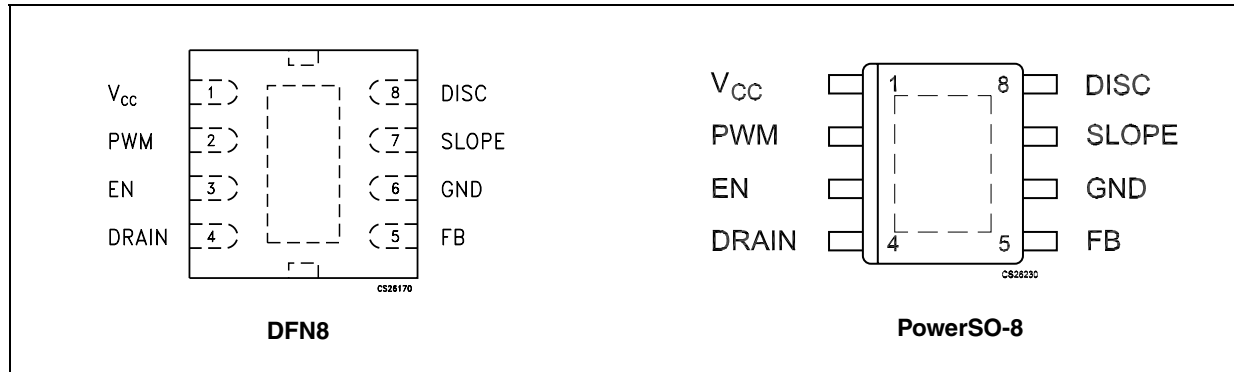

Table 2. Pin description

Pin n°	Symbol	Note
1	V _{CC}	Supply voltage
2	PWM	PWM dimming input
3	EN	Shutdown pin
4	DRAIN	Internal N-MOSFET drain
5	FB	Feedback input. The control loop regulates the current in such a way that the average voltage at the FB input is 100 mV (nominal). The cathode of the LED and a resistor to ground to set the LED current should be connected at this point.
6	GND	Ground
7	SLOPE	Capacitor for slope control
8	DISC	Load disconnection flag (open drain)
	Exp-pad	Internally connected to ground.

3 Maximum ratings

Table 3. Absolute maximum ratings

Symbol	Parameter	Value	Unit
V _{CC}	DC supply voltage	-0.3 to +45	V
DRAIN	Drain pin	-0.3 to +45	
PWM, EN, DISC	Logic pins	-0.3 to + V _{CC} + 0.3	V
SLOPE, FB	Configuration pins	-0.3 to + 3.3	V
ESD	Human body model (all pins)	±2	kV
T _J ⁽¹⁾	Junction temperature	-40 to 150	°C
T _{STG}	Storage temperature range	-55 to 150	°C

1. T_J is calculated from the ambient temperature T_A and the power dissipation P_D according the following formula:
 $T_J = T_A + (P_D \times R_{thJA})$. See [Figure 16](#) and [Figure 17](#) for details of max power dissipation for ambient temperatures higher than 25°C.

Note: Absolute maximum ratings are those values beyond which damage to the device may occur. Functional operation under these conditions is not implied.

Table 4. Thermal data

Symbol	Parameter	DFN8	Power SO-8	Unit
R _{thJC}	Thermal resistance junction-case	10	12	°C/W
R _{thJA}	Thermal resistance junction-ambient	37.6 ⁽¹⁾	45 ⁽²⁾	°C/W

- This value is referred to four-layer PCB, JEDEC standard test board.
- With two sides, two planes PCB following EIA/JEDEC JESD51-7 standard.

4 Electrical characteristics

Table 5. Electrical characteristics ($V_{CC} = 12\text{ V}$; $I_O = 100\text{ mA}$; $T_J = -40\text{ °C}$ to 125 °C ; $V_{DRAIN} = 1\text{ V}$; $C_{DRAIN} = 1\text{ }\mu\text{F}$; $C_{BYP} = 100\text{ nF}$ typical values are at $T_A = 25\text{ °C}$, unless otherwise specified)

Symbol	Parameter	Test conditions	Min.	Typ.	Max.	Unit
V_{CC}	Supply voltage range		4.5		40	V
	Output current range		1		1500	mA
I_O	Output current	$R_{FB} = 0.2\text{ }\Omega$		500		mA
	Regulation (percentage with respect to $V_{CC}=12\text{V}$)	$V_{CC} = 4.5\text{ to }40\text{ V}$, $I_O = 100\text{ mA}$; $V_{DRAIN} = 1\text{ V}$	-1		+1	%
V_{FB}	Feedback voltage	$I_O = 0\text{ to }1.5\text{ A}$	90	100	110	mV
I_{CC}	Quiescent current (Measured on V_{CC} pin)	On Mode		450	750	μA
		Shutdown Mode; $V_{CC} = 5\text{ to }12\text{ V}$			1	
		Shutdown Mode; $V_{CC} = 12\text{ to }40\text{ V}$			3	
V_{DROP}	Dropout voltage (V_{DRAIN} to GND)	$I_O = 100\text{ mA}$		0.12	0.16	V
		$I_O = 1.5\text{ A}$		0.58	0.9	
$LEAK_{DRAIN}$	Drain leakage current	Shutdown; $V_{DRAIN} = 40\text{ V}$			10	μA
T_R/T_F	Rise/Fall time of the current on PWM transition	$C_{SLOPE} = 10\text{ nF}$, $T_J = -40\text{ °C}$ to 105 °C		800		μs
T_D	Delay on PWM signal (see Figure 1)	V_{PWM} rising, $V_{CC} = 12\text{ V}$ $C_{SLOPE} = \text{floating}$		3		μs
		V_{PWM} falling, $V_{CC} = 12\text{ V}$ $C_{SLOPE} = \text{floating}$		1.2		
DISC	Low level voltage	$I_{SINK} = 5\text{ mA}$		0.2	0.5	V
	Leakage current	$V_{DISC} = 5\text{ V}$			1	μA
	Load disconnection threshold (V_{DRAIN} -GND)	DISC Turn-ON			75	mV
		DISC Turn-OFF			110	
Thermal Protection	Shutdown temperature			155		$^{\circ}\text{C}$
	Hysteresis			25		
Logic Inputs (PWM and EN)						
V_L	Input low level				0.4	V
V_H	Input high level		1.2			V
	EN, PWM leakage current	$V_{EN} = 5\text{ V}$; $V_{PWM} = 5\text{ V}$			2	μA
	EN input leakage current	$V_{EN} = 40\text{ V}$			60	
	PWM input leakage current	$V_{PWM} = 40\text{ V}$			120	

Note: All devices 100 % production tested at $T_A = 25\text{ °C}$. Limits over the operating temperature range are guaranteed by design.

5 Timing

Figure 3. PWM and output current timing



Figure 4. Block diagram

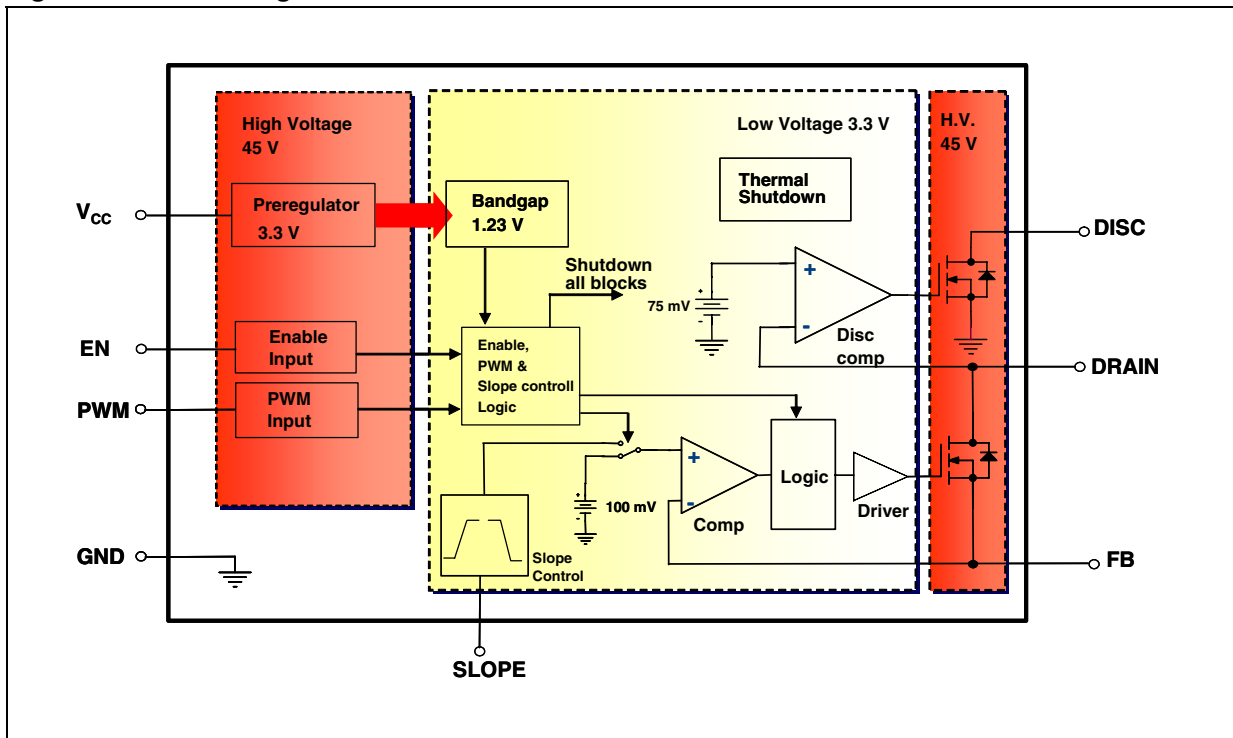

6 Typical performance characteristics

Figure 5. I_{DRAIN} vs V_{CC} , $T_A = 25^\circ C$



Figure 6. I_{DRAIN} vs R_{SET}

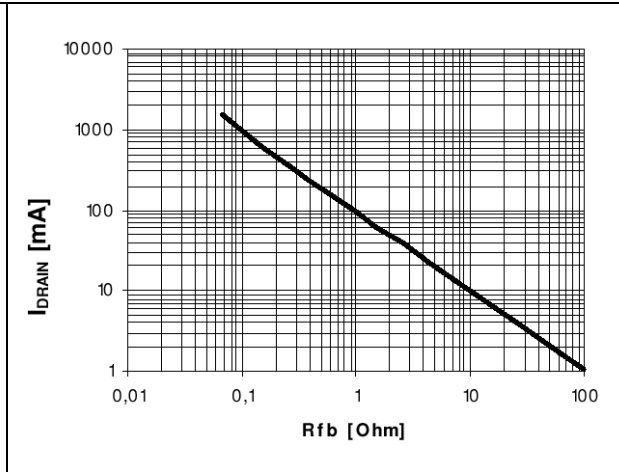

Figure 7. I_{DRAIN} vs Temperature



Figure 8. V_{DROP} (including V_{FB}) vs temperature



Figure 9. I_{CC} vs Temperature



Figure 10. I_{CC} vs V_{CC}

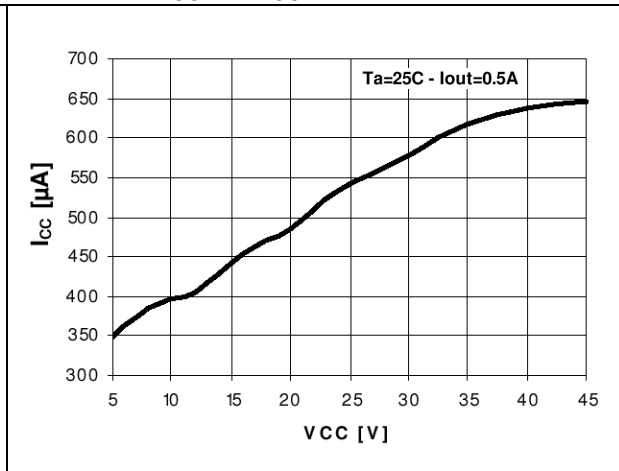

Figure 11. T_{rise}/T_{fall} vs C_{SLOPE}

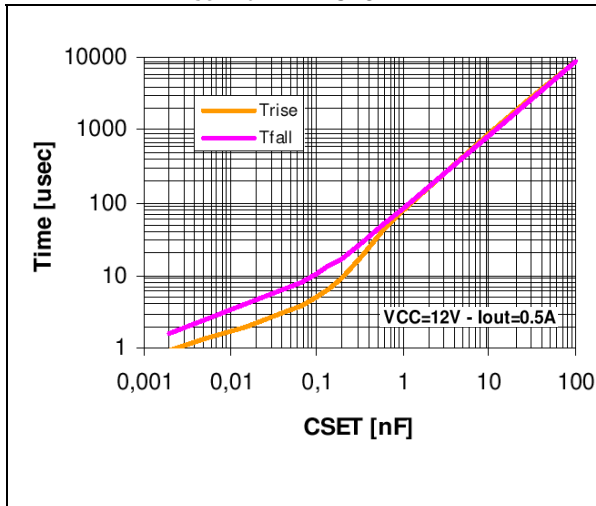

Figure 12. Turn-on time

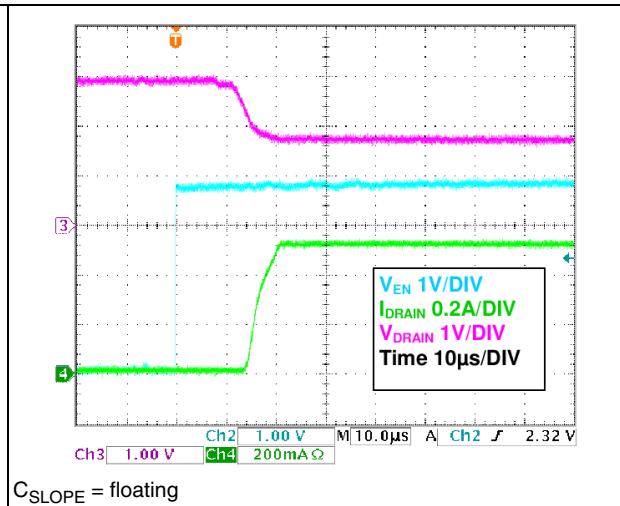

Figure 13. Dimming operation: Rise

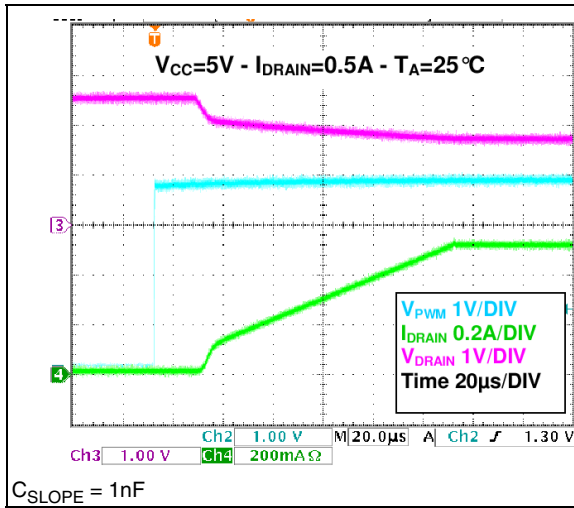
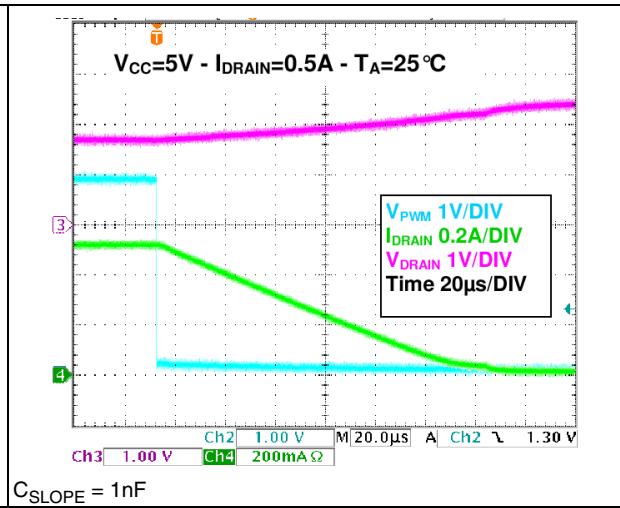

Figure 14. Dimming operation: Fall



7 Detail description

The STCS1A is a BiCMOS constant current source designed to provide a precise constant current starting from a varying input voltage source. The main target is to replace discrete components solution for driving LEDs in low voltage applications such as 5 V, 12 V or 24 V giving benefits in terms of precision, integration and reliability.

7.1 Current setting

The current is set with an external sensing resistor connected to the FB pin. The feedback voltage is 100 mV, then a low resistor value can be chosen reducing power dissipation. A value between 1 for instance, should one need a 700 mA LEDs current, R_F should be selected according to the following equation:

For instance, should one need a 700 mA LEDs current, R_F should be selected according to the following equation:

$$R_F = V_{FB} / I_{LEDs} = 100 \text{ mV} / 700 \text{ mA} = 142 \text{ m}\Omega$$

7.2 Enable

When the enable pin is low the device completely off thus reducing current consumption to less than 1 μ A. When in shutdown mode, the internal main switch is off.

7.3 PWM dimming

The PWM input allows implementing PWM dimming on the LED current; when the PWM input is high the main switch will be on and vice versa. A typical frequency range for the input is from few Hertz to 50 kHz. The maximum dimming frequency is limited by the minimum rise/fall time of the current (obtained with $C_{SLOPE} = 0$) which is around 4 μ s each. Above 50 kHz the current waveforms starts assuming a triangular shape.

While the PWM input is switching, the overall circuitry remains on, this is needed in order to implement two important features: short delay time and controlled slope for the current.

Since the PWM pin is controlling just the main switch, the overall circuitry is always on and it is able to control the delay time between the PWM input signal and the output current in the range of few μ s, this is important to implement synchronization among several light LED sources.

The rise and fall slope of the current is controlled by the C_{SLOPE} capacitor. The rise and fall time are linear dependent from the C_{SLOPE} capacitor value (see graph in typical characteristics). A controlled rise time has two main benefits: reducing EMI noise and avoid current spike at turn on.

When C_{SLOPE} is left floating, the internal switch is turned on at maximum speed, in this condition an overshoot can be present on the LED current before the system goes into regulation.

7.4 Diagnostic

When STCS1A is in on mode (EN is high), the device is able to detect disconnection or fail of the LED string monitoring V_{DRAIN} pin. If V_{DRAIN} is lower than 75 mV the DISC pin is pulled low regardless the PWM pin status. This information can be used by the system to inform that some problem happens in the LEDs.

8 Application information

8.1 Reverse polarity protection

STCS1A must be protected from reverse connection of the supply voltage. Since the current sunk from V_{CC} pin is in the range of $450 \mu\text{A}$ a small diode connected to V_{CC} is able to protect the chip. Care must be taken for the whole application circuit, especially for the LEDs, in fact, in case a negative voltage is applied between V_{IN} and GND, a negative voltage will be applied to the LED string that must have a total breakdown voltage higher than the negative applied voltage in order to avoid any damage.

Figure 15. Reverse polarity condition

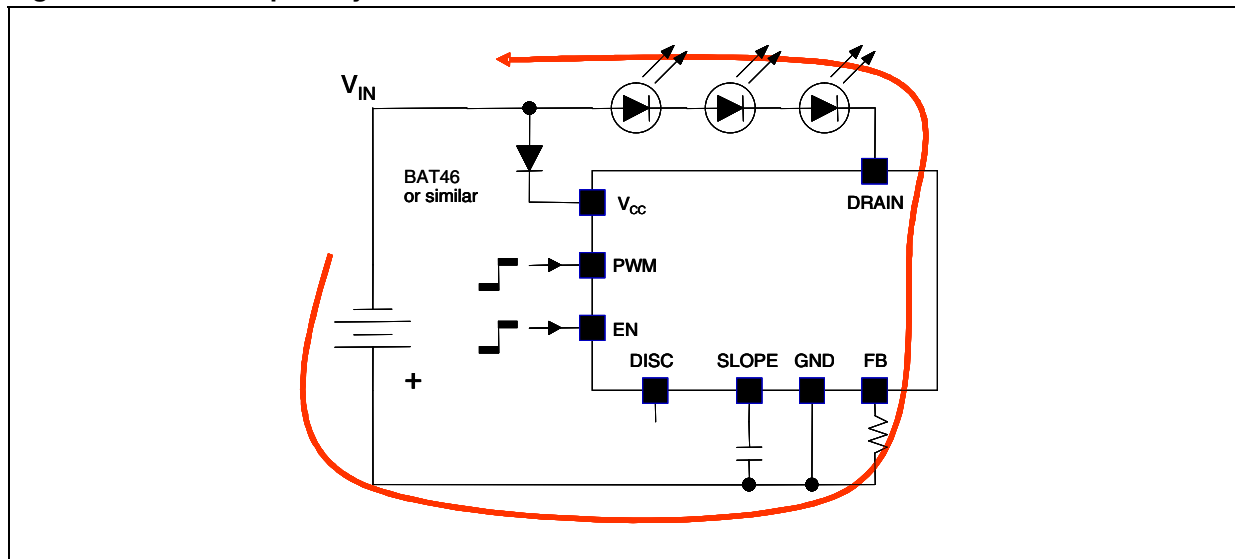

8.2 Thermal considerations

The STCS1A is able to control a LED current up to 1.5 A and able to sustain a voltage on the drain pin up to 40 V. Those operating conditions are however limited by thermal constraints, the thermal resistances shown in the [Thermal data](#) section are the typical ones, in particular R_{thJA} depends on the copper area and the number of layers of the printed circuit board under the pad. DFN8 and PowerSO-8 have an exposed die attach pad which enhances the thermal conductivity enabling high power application.

The power dissipation in the device can be calculated as follow:

$$P_D = (V_{DRAIN} - V_{FB}) \times I_{LED} + (V_{CC} \times I_{CC})$$

basing on this and on the thermal resistance and ambient temperature, the junction temperature can be calculated as:

$$T_J = R_{thJA} \times P_D + T_A$$

A typical application could be:

- Input voltage: 12 V;
- 3 white LEDs with an typical $V_F=3.6 \text{ V}$;

- LEDs current: 500 mA;
- Package: DFN8 3x3 mm;
- $T_A = 50^\circ\text{C}$;

In this case $V_{\text{DRAIN}} = 12 - 3 \times 3.6 = 1.2 \text{ V}$

$$P_D = (1.2 - 0.1) \times 0.5 + 12 \times 0.5 \times 10^{-3} = 0.55 + 6 \times 10^{-3} = 556 \text{ mW}$$

The junction temperature will be:

$$T_J = 37.6 \times 0.556 + 50 = 70.9 \text{ }^\circ\text{C}$$

The following pictures show the maximum power dissipation according to the ambient temperature for both packages:

Figure 16. Maximum power dissipation vs T_A for DFN8 3x3 mm

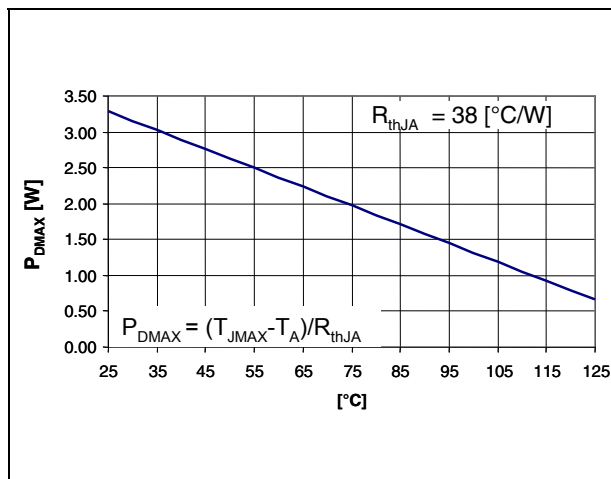
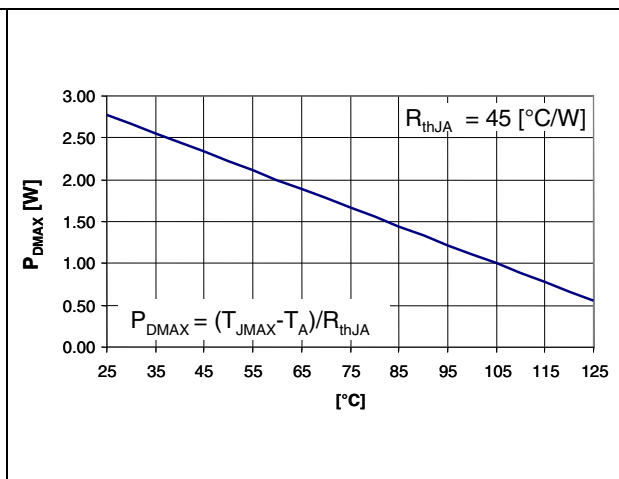

Figure 17. Maximum power dissipation vs T_A for PowerSO-8



9 Package mechanical data

In order to meet environmental requirements, ST offers these devices in ECOPACK® packages. These packages have a lead-free second level interconnect. The category of second Level Interconnect is marked on the package and on the inner box label, in compliance with JEDEC Standard JESD97. The maximum ratings related to soldering conditions are also marked on the inner box label. ECOPACK is an ST trademark. ECOPACK specifications are available at: www.st.com.

DFN8 (3x3 mm) mechanical data

Dim.	mm.			mils.		
	Min.	Typ.	Max.	Min.	Typ.	Max.
A	0.80	0.90	1.00	31.5	35.4	39.4
A1		0.02	0.05		0.8	2.0
A2		0.70			27.6	
A3		0.20			7.9	
b	0.18	0.23	0.30	7.1	9.1	11.8
D		3.00			118.1	
D2	2.23	2.38	2.48	87.8	93.7	97.7
E		3.00			118.1	
E2	1.49	1.64	1.74	58.7	64.6	68.5
e		0.50			19.7	
L	0.30	0.40	0.50	11.8	15.7	19.7

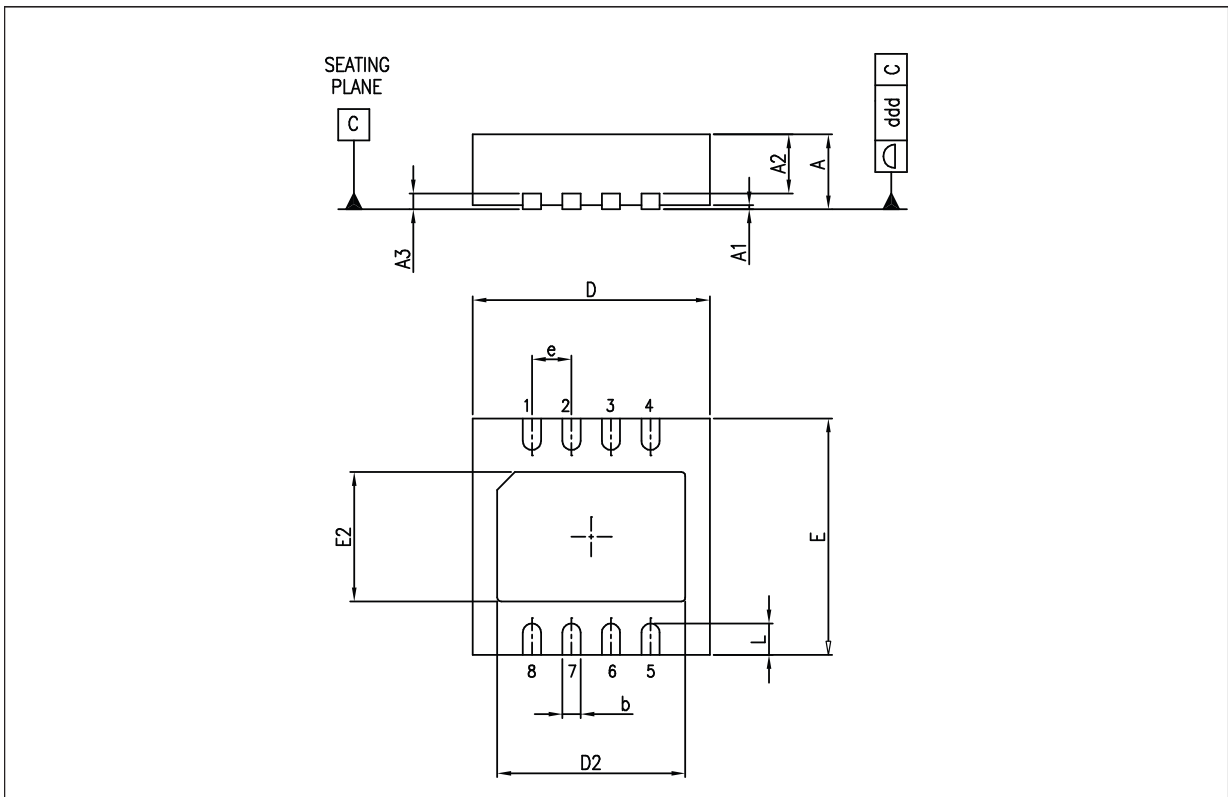

PowerSO-8 mechanical data

Dim.	mm.			inch.		
	Min.	Typ.	Max.	Min.	Typ.	Max.
A			1.70			0.067
A1	0.00		0.15	0.00		0.006
A2	1.25			0.049		0.142
b	0.31		0.51	0.012		0.020
c	0.17		0.25	0.007		0.010
D	4.80	4.90	5.00	0.189	0.193	0.197
D1	2.24	3.10	3.20	0.088	0.122	0.126
E	5.80	6.00	6.20	0.228	0.236	0.244
E1	3.80	3.90	4.00	0.150	0.154	0.157
E2	1.55	2.41	2.51	0.061	0.095	0.099
e		1.27			0.050	
h	0.25		0.50	0.010		0.020
L	0.40		1.27	0.016		0.050
k	0°		8°	0°		8°
ccc			0.10			0.004

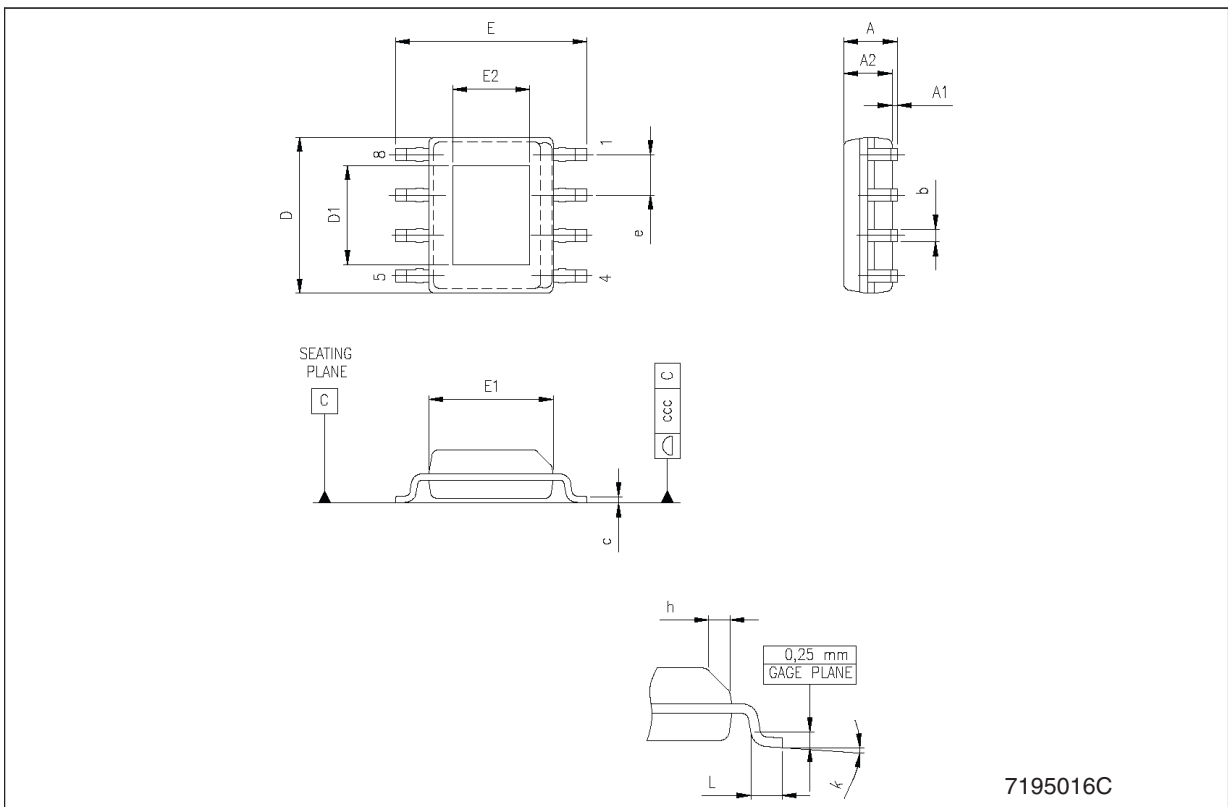

Tape & reel QFNxx/DFNxx (3x3) mechanical data

Dim.	mm.			inch.		
	Min.	Typ.	Max.	Min.	Typ.	Max.
A			180			7.087
C	12.8		13.2	0.504		0.519
D	20.2			0.795		
N	60			2.362		
T			14.4			0.567
Ao		3.3		0.130		
Bo		3.3		0.130		
Ko		1.1		0.043		
Po		4		0.157		
P		8		0.315		

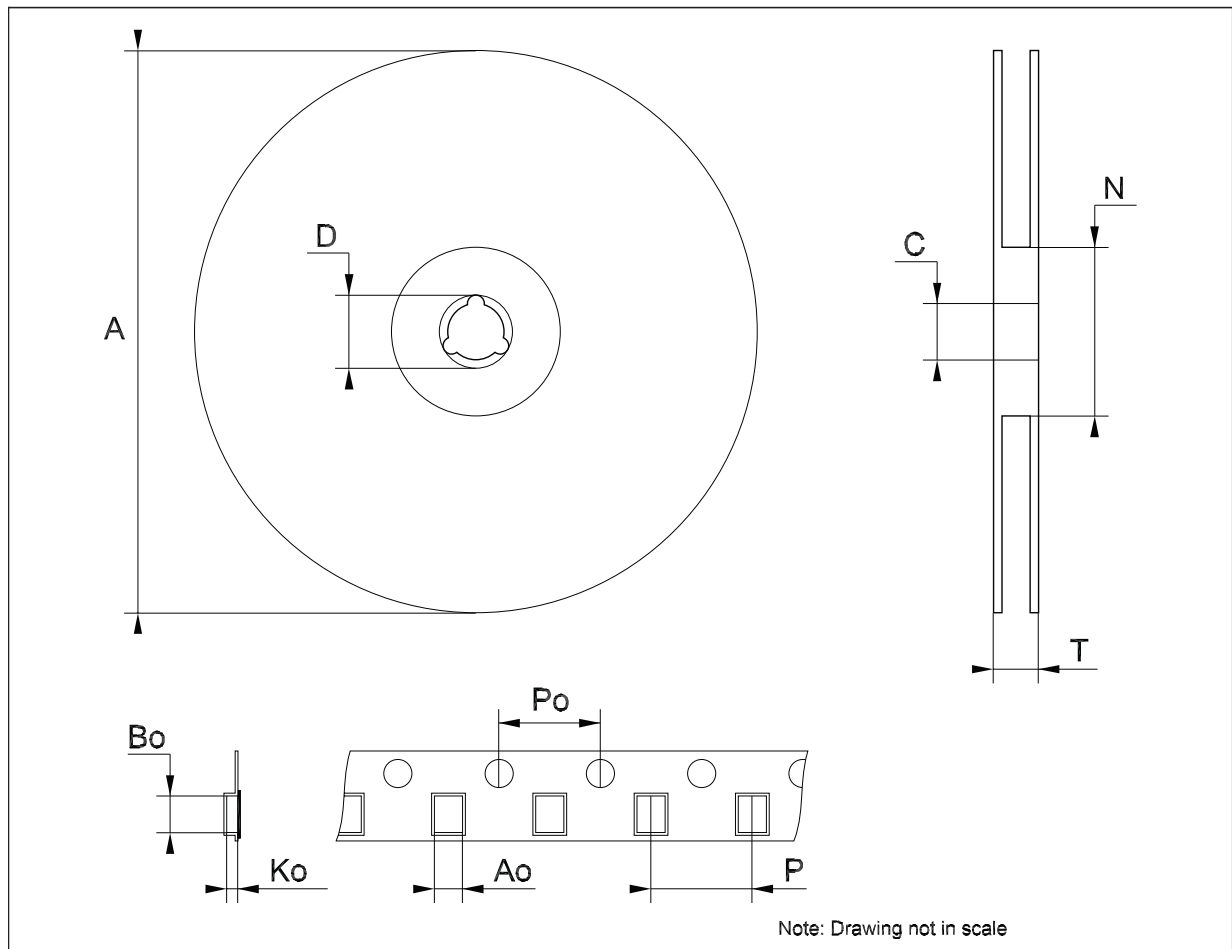

10 Revision history

Table 6. Document revision history

Date	Revision	Changes
19-Feb-2008	1	Initial release.
02-Jul-2008	2	Modified: Table 5 on page 6.