

Evaluation board based on the ST1PS01EJR 400 mA nano-quiescent synchronous step-down converter

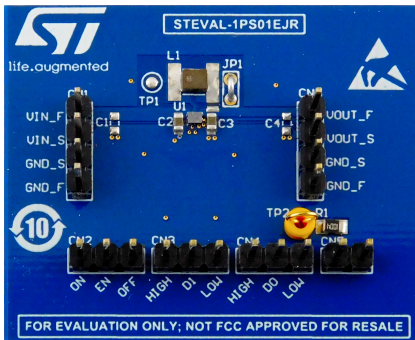

Features

- 94% typical efficiency at 1 mA load ($V_{IN}=3.6\text{ V}$, $V_{OUT}=3.3\text{ V}$)
- 1.8 V to 5.5 V input operating range
- Up to 400 mA output current capability
- Tiny external components: $L=2.2\text{ }\mu\text{H}$ typ.
- Selectable output voltages: 1.8 V to 3.3 V
- Output voltage Power Good
- Dynamic output voltage selection (D0, D1)
- Suitable for the following applications:
 - Wearable applications
 - Personal tracking monitors
 - Smart watches, sport bands
 - Energy harvesting, wireless sensors
 - Wearable and fitness accessories
 - Industrial sensors, portable low power devices
 - Single cell Li-Ion battery applications
 - Bluetooth[®] low energy
 - ZigBee[®]
- Hardware is WEEE and RoHS compliant

Product summary

Evaluation board for ST1PS01 step-down converter	STEVAL-1PS01EJR
400 mA nano-quiescent synchronous step-down converter with digital voltage selection and power good	ST1PS01

Description

The STEVAL-1PS01EJR evaluation board features the ST1PS01 nano-quiescent miniaturized synchronous step-down converter that is designed for applications where high efficiency, PCB size and thickness are key factors.

The converter can provide up to 400 mA output current with an input voltage ranging from 1.8 V to 5.5 V. The output voltage can be dynamically adjusted from 1.8 V to 3.3 V using two digital control inputs.

Thanks to the enhanced peak current control (PCC), the ST1PS01 can achieve very high conversion efficiency using only a 2.2 μH inductor and two small capacitors.

The advanced design circuitry minimizes quiescent current.

1 Block diagram

Figure 1. STEVAL-1PS01EJR block diagram

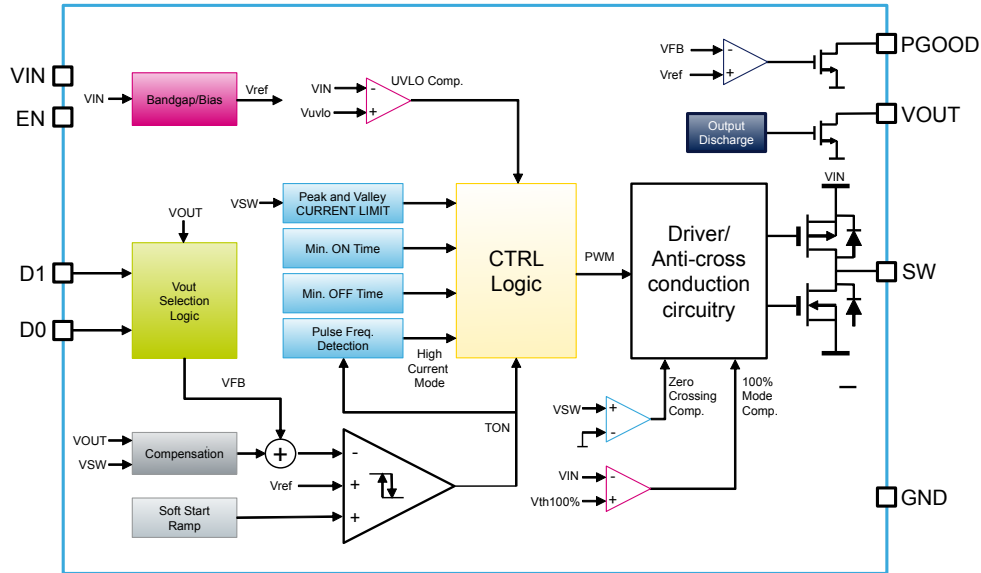

2 Schematic diagrams

Figure 2. STEVAL-1PS01EJR schematic

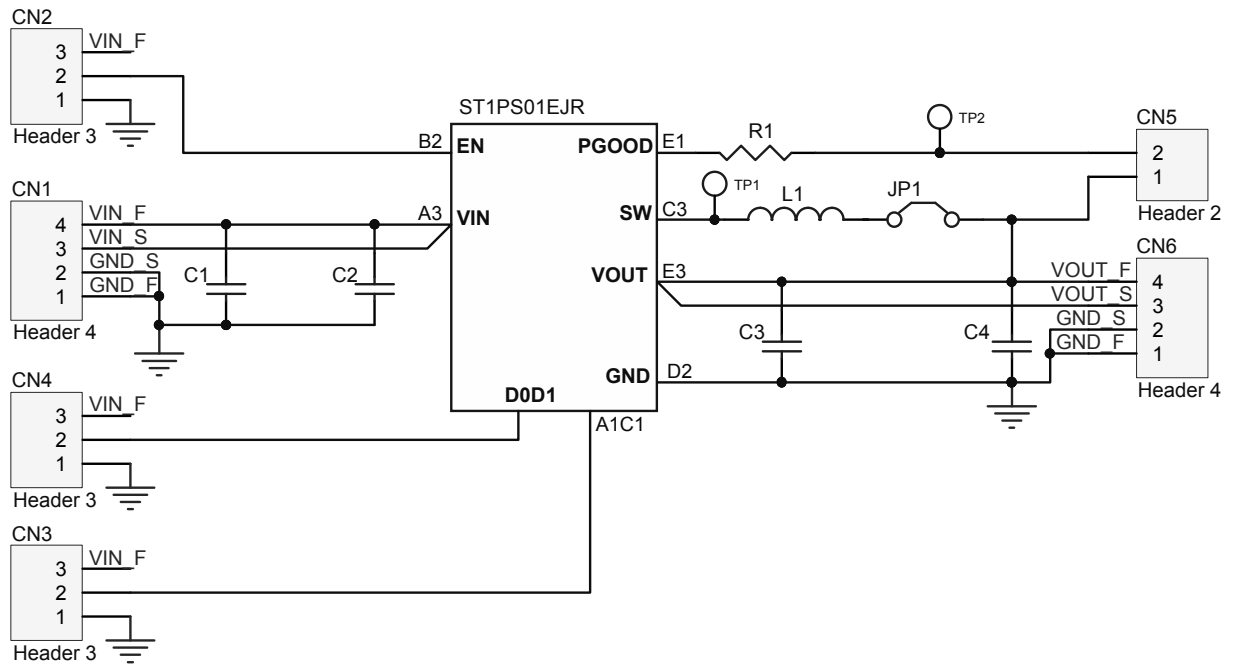

Revision history

Table 1. Document revision history

Date	Version	Changes
21-Dec-2018	1	Initial release.
17-Jun-2019	2	Updated features and photo in cover page.