

Evaluation board based on ST1PS02AQTR 400 mA nano-quiescent synchronous step-down converter with AUX switch

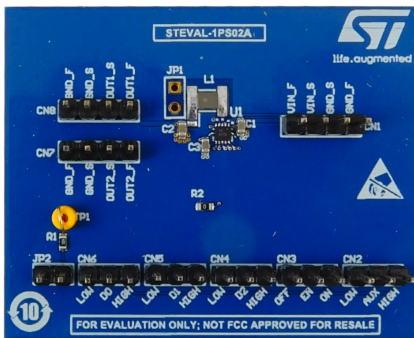

Features

- 1.8 to 5.5 V input operating range
- Up to 400 mA output current capability
- Tiny external components: L = 2.2 μ H typ.
- Dynamically selectable output voltages from 1.4 to 1.75 V
- Output voltage power good
- Auxiliary load switch Vout2 (AUX control input)
- WEEE and RoHS compliant (hardware only)

Description

The **STEVAL-1PS02A** evaluation board allows evaluation of a smart converter design able to deliver up to 400 mA output current from a 1.8 V to 5.5 V input, with a dynamically adjustable 1.4 V to 1.75 V output voltage.

The board embeds the **ST1PS02AQTR** nano-quiescent miniaturized synchronous step-down converter which implements enhanced peak current control (PCC) and advanced design circuitry to minimize quiescent current. It features a controlled load switch to supply a subsystem with the same voltage rail. The device is supplied in TQFN12 (2.0x1.7 mm) thin package, but other packages are also available.

The board demonstrates how highly efficient conversion can be achieved using just the **ST1PS02AQTR**, a 2.2 μ H inductor and two small capacitors.

The board highlights **ST1PS02AQTR** key application benefits, including high efficiency and small PCB size and thickness, and is ideal for power conversion solutions in wearable applications, fitness accessories, personal tracking monitors, smart watches, sports bands, energy harvesting, wireless sensors, industrial sensors, portable low power devices, single cell Li-Ion battery applications as well as Bluetooth® low energy and Zigbee applications.

Product summary	
Evaluation board based on ST1PS02AQTR 400 mA nano-quiescent synchronous step-down converter with AUX switch	STEVAL-1PS02A
400mA nano-quiescent synchronous step-down converter with digital voltage selection, Power Good and AUX switch	ST1PS02AQTR
Application	Buck Converter

1 Schematic diagrams

Figure 1. STEVAL-1PS02A circuit schematic

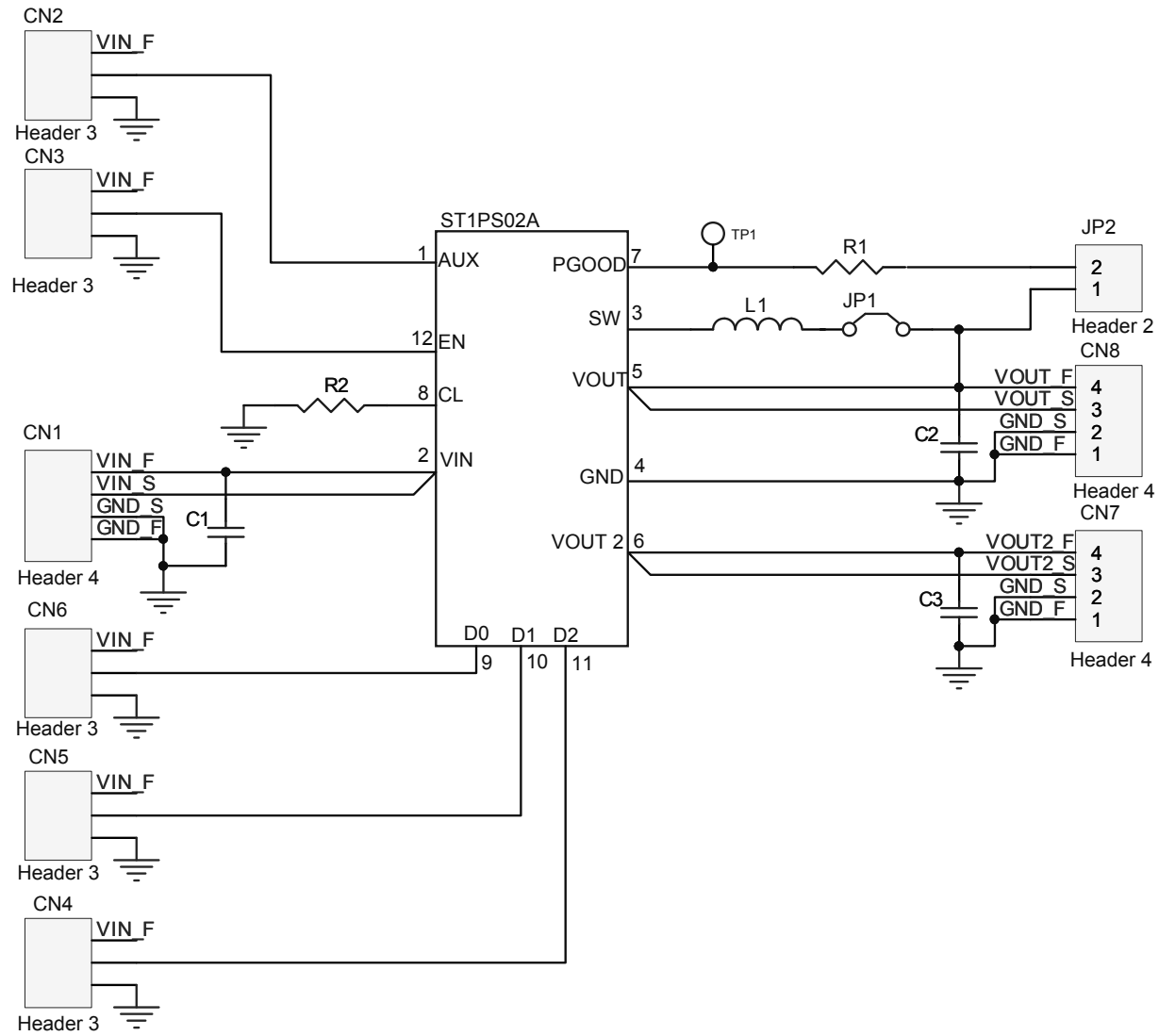

Revision history

Table 1. Document revision history

Date	Version	Changes
19-May-2021	1	Initial release.