

Evaluation kit for high precision bidirectional current sense amplifiers

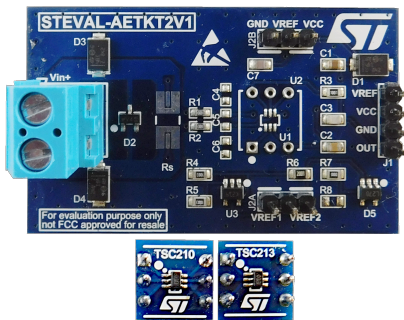

Features

- Input common mode voltage: 26 V
- Offset voltage: $\pm 35 \mu\text{V}$ ($\pm 100 \mu\text{V}$) max.
- Offset drift: $0.1 \mu\text{V}/^\circ\text{C}$ max.
- Gain drift: $20 \text{ ppm}/^\circ\text{C}$ max.
- 2.7 to 26 V supply voltage
- Quiescent current: $100 \mu\text{A}$ max.
- SC70-6 and QFN10 (1.8 x 1.4 mm) package
- Temperature range: -40 to 125°C
- Gain configuration from 50 V/V to 1000 V/V
- RoHS compliant

Description

The STEVAL-AETKT2V1 evaluation kit implements bidirectional current sense amplifiers by placing a sense resistor either in the high-side or in the low-side.

The STEVAL-AETKT2V1 kit consists of a motherboard and two different daughter boards for different gain configurations.

The TSC21x family implements zero drift technology and is specially designed to accurately measure current by amplifying the voltage across a shunt resistor connected to its input. The voltage drop (V_{sense}) is then amplified by an amplifier.

Thanks to the use of thin film resistors, the TSC21x offers an extremely precise gain and very high CMRR performance.

Moreover, thanks to the possibility of fixing the output common mode voltage through a reference pin, the TSC21x can be either used as a unidirectional or bidirectional current sensing amplifier.

Product summary	
Evaluation kit for high precision bidirectional current sense amplifiers	STEVAL-AETKT2V1
Low/high-side bidirectional, zero-drift, current sense amplifiers	TSC210/TSC213
Applications	Electro-mobility Factory automation Industrial power tools

1 Schematic diagrams

Figure 1. STEVAL-AETKT2V1 main board (STEVAL-AET011V1B) circuit schematic

The STEVAL-AET011V1B board is not available for separate sale.

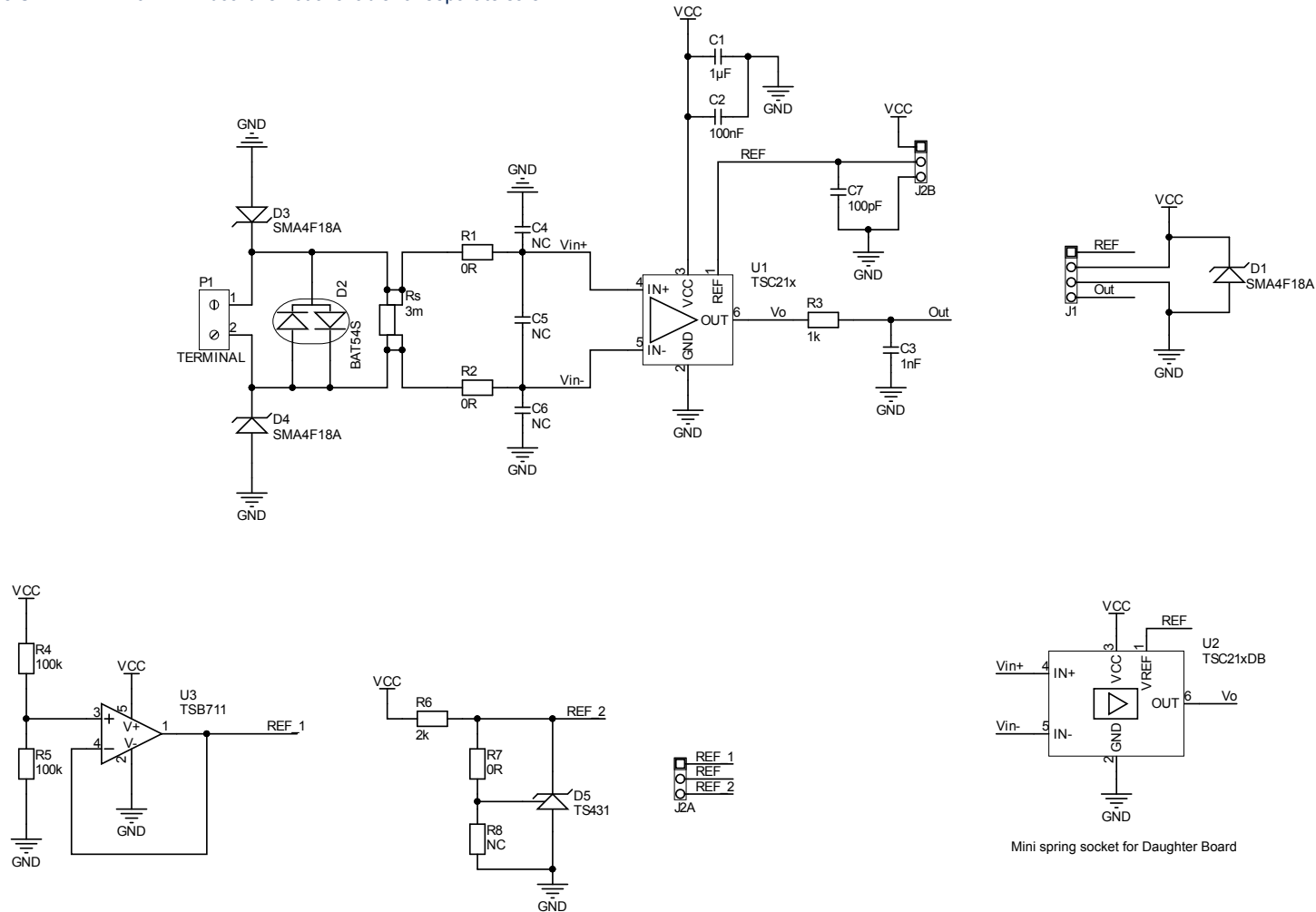
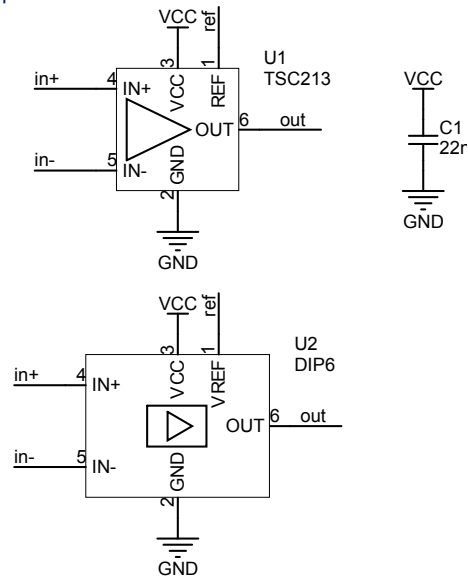
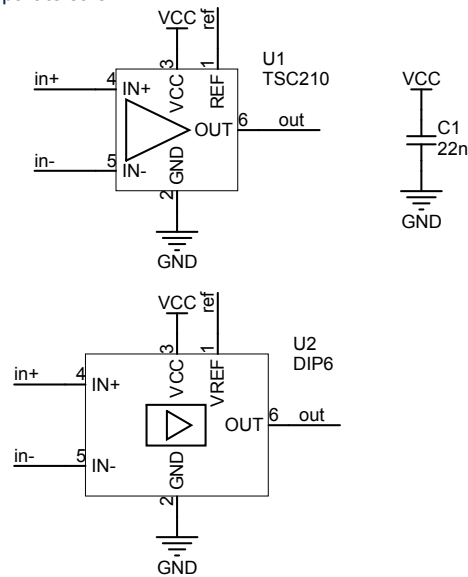

Figure 2. STEVAL-AETKT2V1 daughterboard (STEVAL-AET012V1B) circuit schematic

The STEVAL-AET012V1B board is not available for separate sale.

**Figure 3. STEVAL-AETKT2V1 daughterboard (STEVAL-AET013V1B) circuit schematic**

The STEVAL-AET013V1B board is not available for separate sale.



Revision history

Table 1. Document revision history

Date	Revision	Changes
08-June-2021	1	Initial release.