

Multiconnectivity asset tracking reference design based on STM32WB5MMG and STM32WL55JC



Features

- Ultra-low-power and multiconnectivity asset tracking platform
- Two wireless SoCs:
 - [STM32WB5MMG](#) 2.4 GHz wireless dual core SoC module as main application processor, which supports Bluetooth® Low Energy 5.0
 - [STM32WL55JC](#) sub 1-GHz wireless dual core SoC, which supports multimodulation (LoRa and GFSK)
- [ST25DV64K](#) for NFC connectivity
- [Teseo-LIV3F](#) GNSS module with simultaneous multiconstellation
- Environmental and motion sensors: [STTS22H](#), [LPS22HH](#), [HTS221](#), [LIS2DTW12](#), and [LSM6DSO32X](#)
- [STSAFE-A110](#) secure element
- Battery-operated solution with smart power management architecture ([ST1PS02](#), [STBC03](#), and [TCPP01-M12](#))
- [FP-ATR-ASTRA1 STM32Cube](#) function pack
- End-to-end proof of concept ecosystem mobile app and cloud dashboard:
 - [DSH-ASSETTRACKING](#) web cloud dashboard
 - [STAssetTracking](#) mobile app available on Google Play and App store
- 480 mAh LiPo battery
- Plastic case
- SMA antenna
- NFC antenna
- Operating conditions: +5 to 35°C

Description

The ASTRA platform ([STEVAL-ASTRA1B](#)) is a development kit and reference design that simplifies prototyping, testing and evaluating advanced asset tracking applications such as livestock monitoring, fleet management, and logistics.

It comes with comprehensive software, firmware libraries, tools, battery, and plastic case. Thanks to its modular and optimized design, it simplifies the development of tracking and monitoring innovative solutions.

The [STEVAL-ASTRA1B](#) is built around the [STM32WB5MMG](#) module and the [STM32WL55JC](#) SoC for short and long range connectivity (BLE, LoRa, and 2.4 GHz and sub 1-GHz proprietary protocols). [ST25DV64K](#) for NFC connectivity is also available. The on-board [STSAFE-A110](#) enhances security features.

The kit embeds a complete set of environmental and motion sensors ([LIS2DTW12](#), [LSM6DSO32X](#), [HTS221](#), [STTS22H](#), [LPS22HH](#)). Moreover, the [Teseo-LIV3F](#) GNSS module provides outdoor positioning.

The power management, built around [ST1PS02](#) and [STBC03](#), is optimized for long battery life.

Product summary	
Multiconnectivity asset tracking reference design based on STM32WB5MMG and STM32WL55JC	STEVAL-ASTRA1B
STM32Cube function pack for the STEVAL-ASTRA1B multiconnectivity asset tracking reference design	FP-ATR-ASTRA1
Ultra-low-power dual-core Arm® Cortex®-M4/M0+ MCU	STM32WB5MMG H6TR
Sub-GHz wireless dual-core Arm® Cortex®-M4/M0+ MCU	STM32WL55JC17
ST Asset Tracking application for Android and iOS	STAssetTracking
Cloud Amazon-based web application for asset tracking	DSH-ASSETTRACKING
Applications	Asset Tracking/Smart Farming

1 Kit assembly

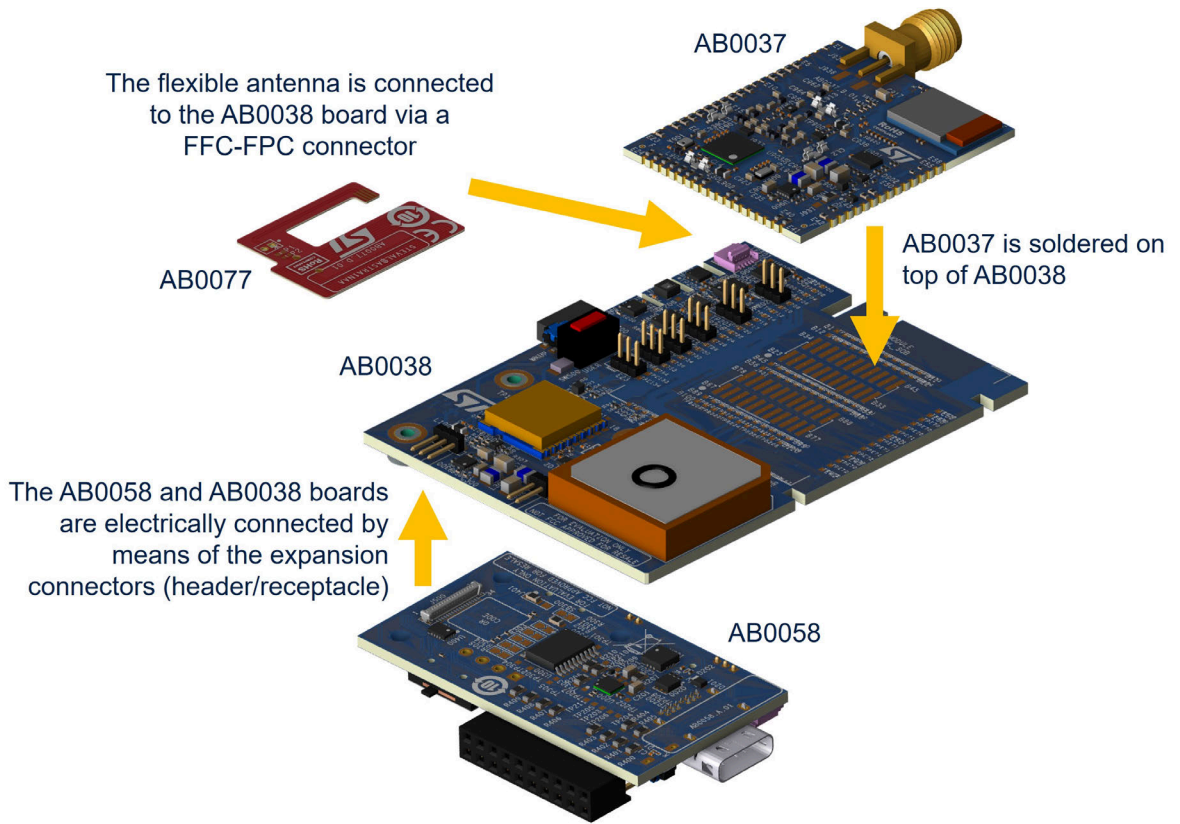

Figure 2. Main board (STEVAL-ASTRA1) circuit schematic (2 of 9)

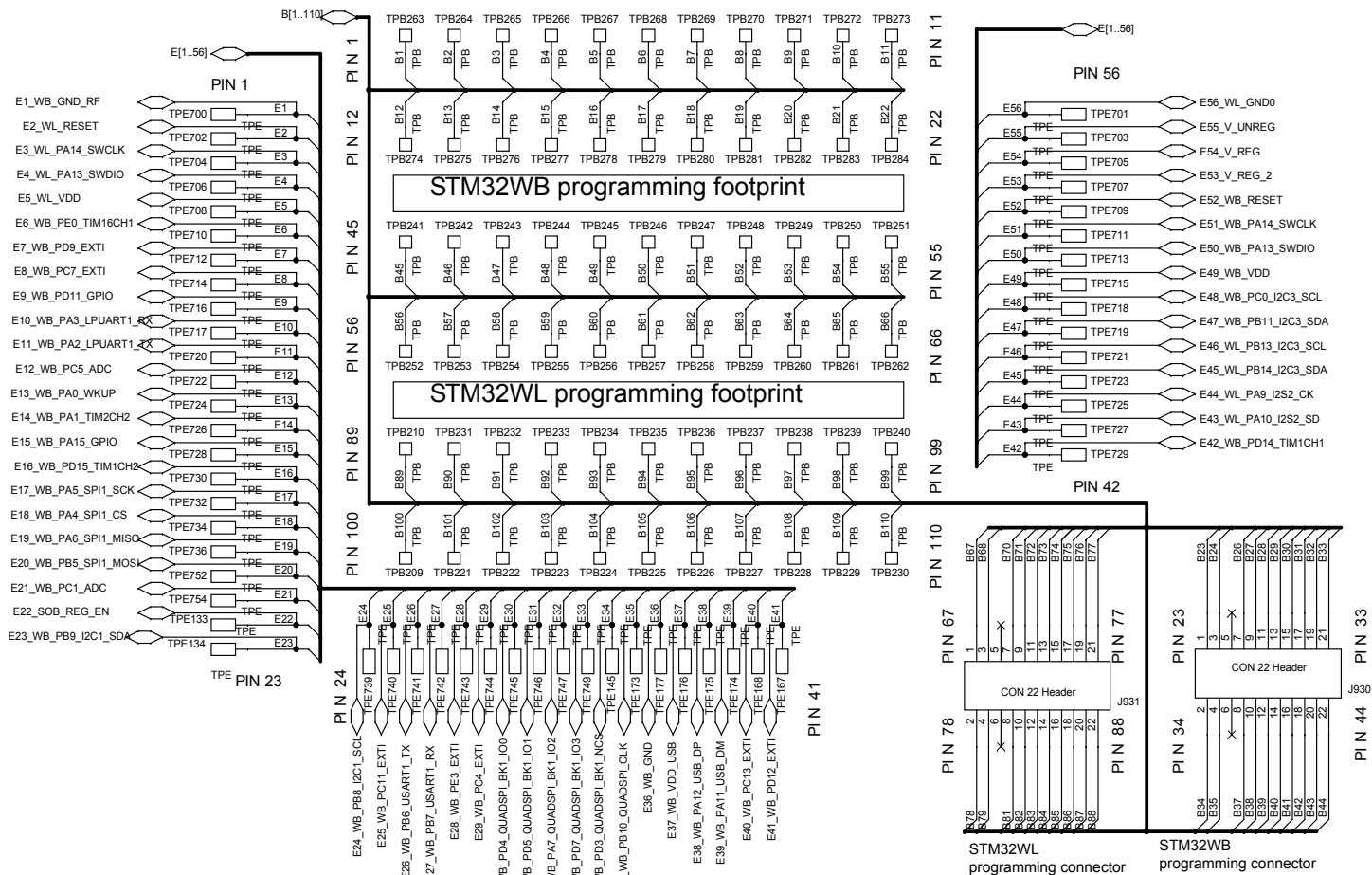

Figure 3. Main board (STEVAL-ASTRA1) circuit schematic (3 of 9)

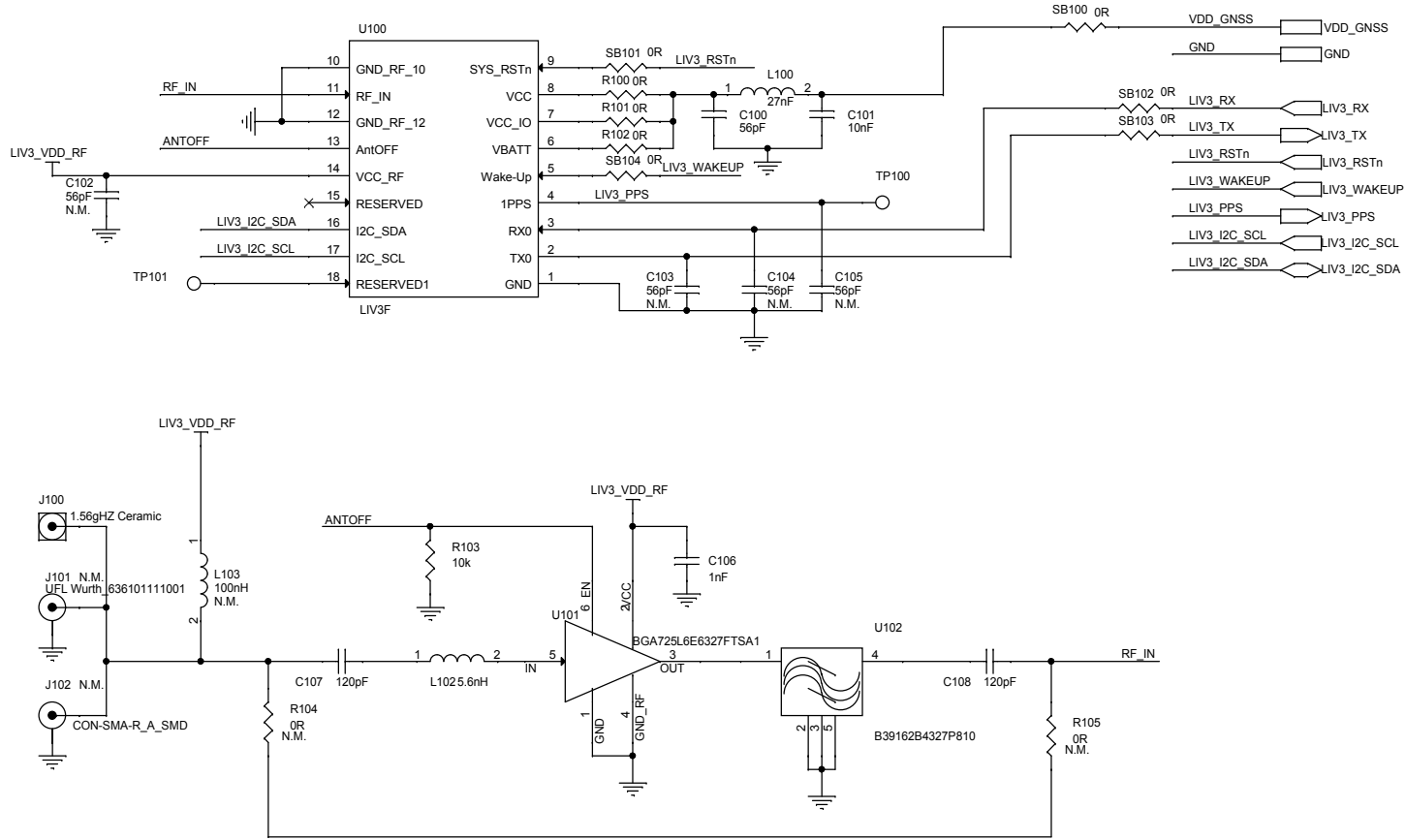

Figure 4. Main board (STEVAL-ASTRA1) circuit schematic (4 of 9)

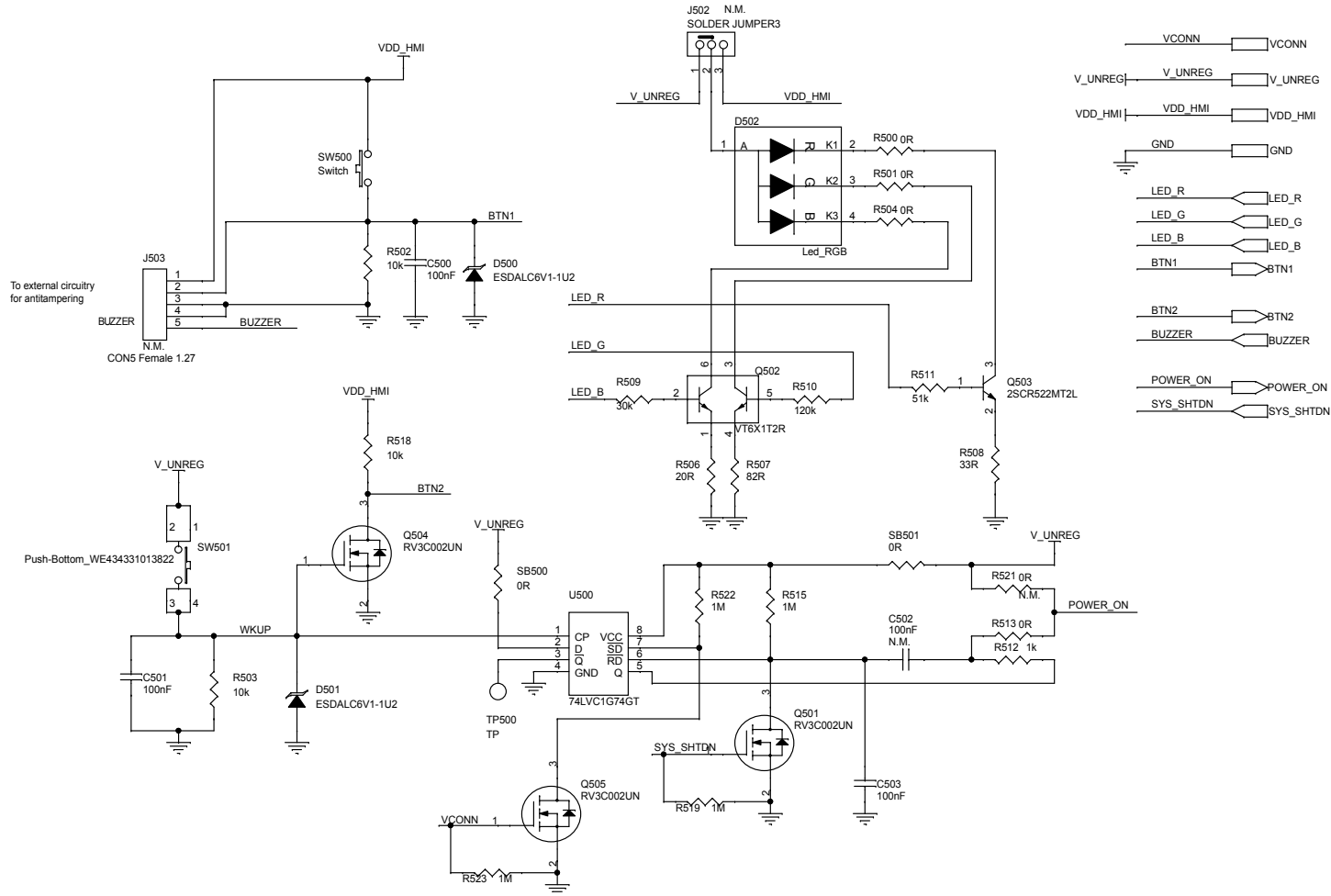

Figure 6. Main board (STEVAL-ASTRA1) circuit schematic (6 of 9)

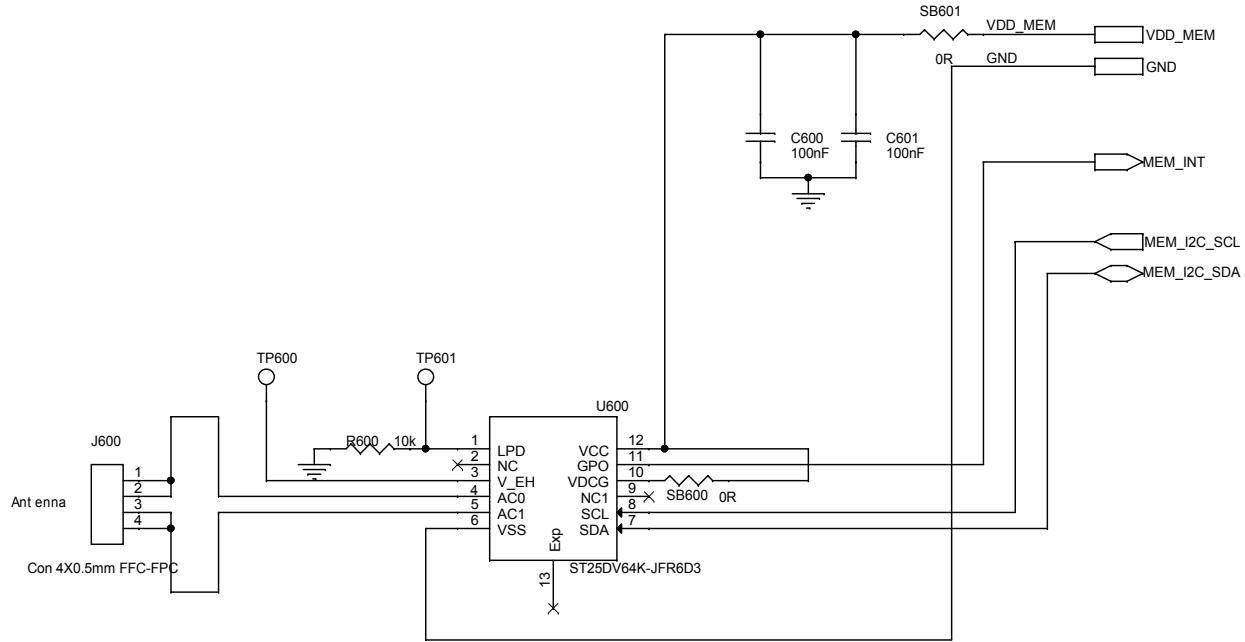

Figure 7. Main board (STEVAL-ASTRA1) circuit schematic (7 of 9)

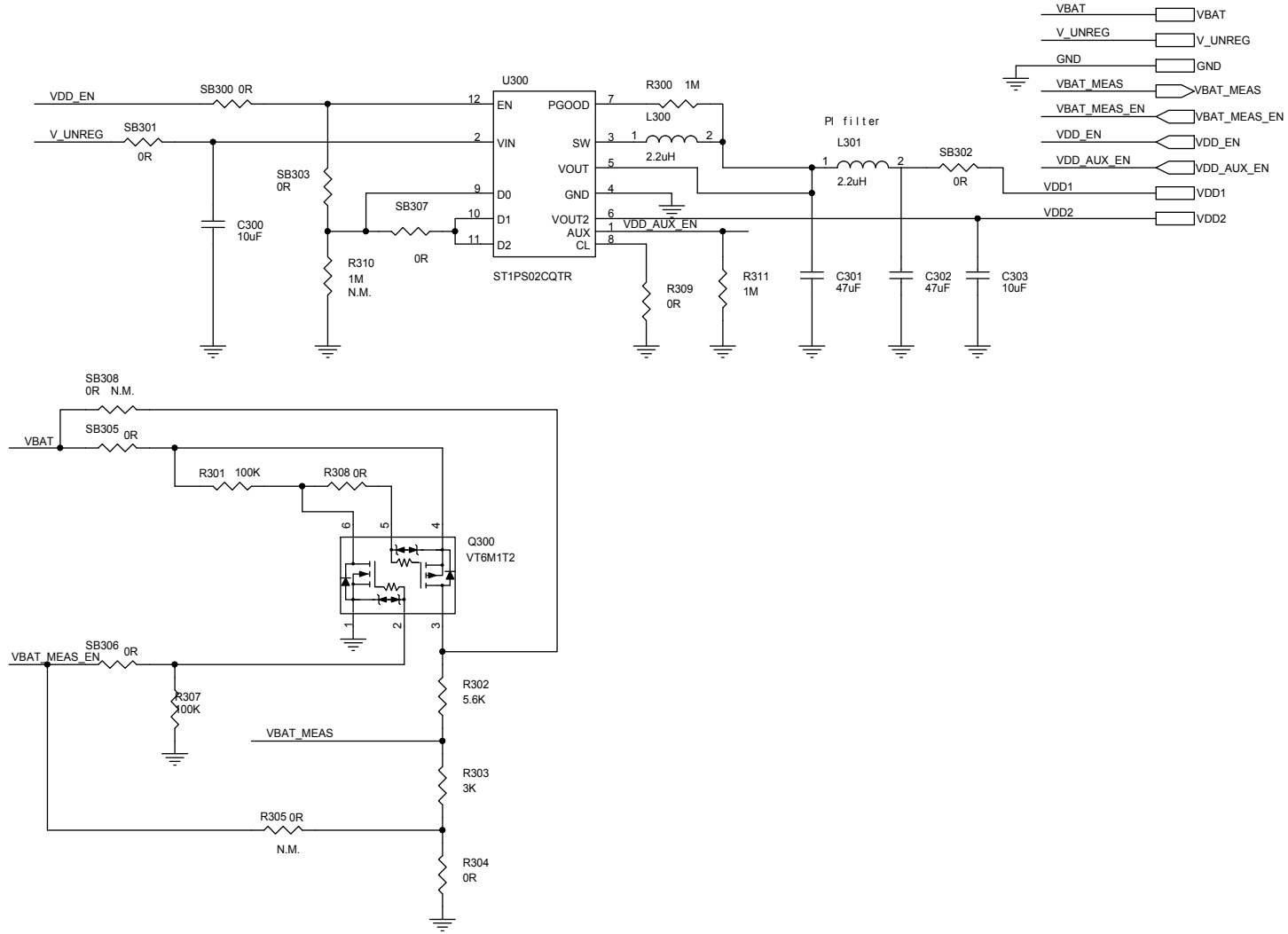

Figure 8. Main board (STEVAL-ASTRA1) circuit schematic (8 of 9)

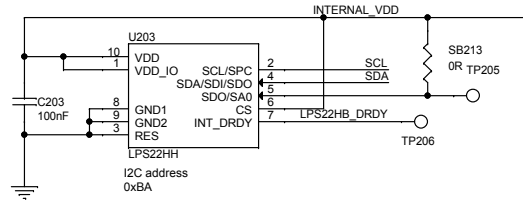
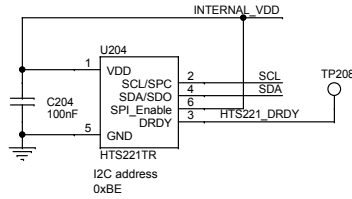
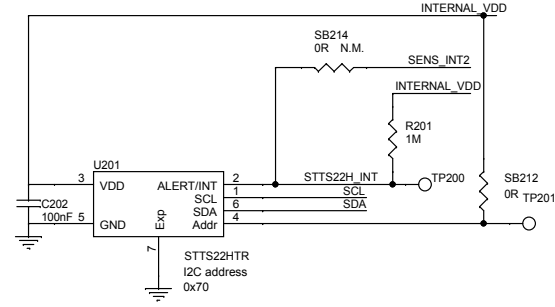
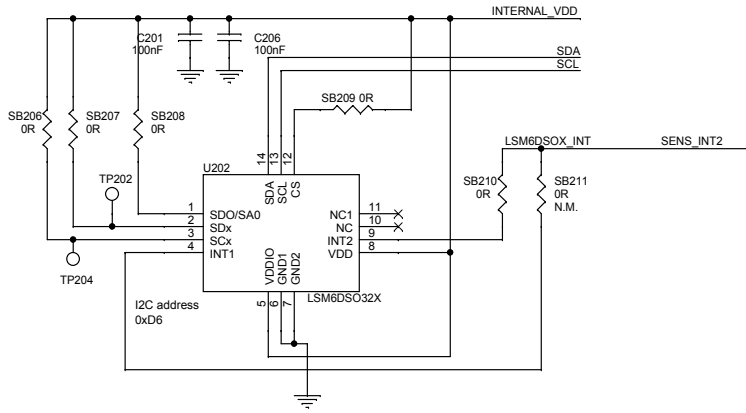
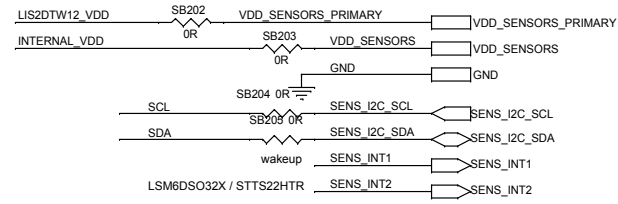
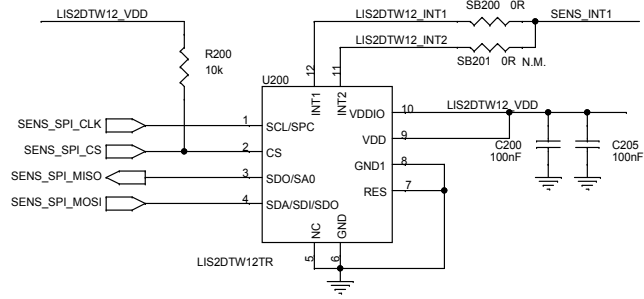

Figure 9. Main board (STEVAL-ASTRA1) circuit schematic (9 of 9)

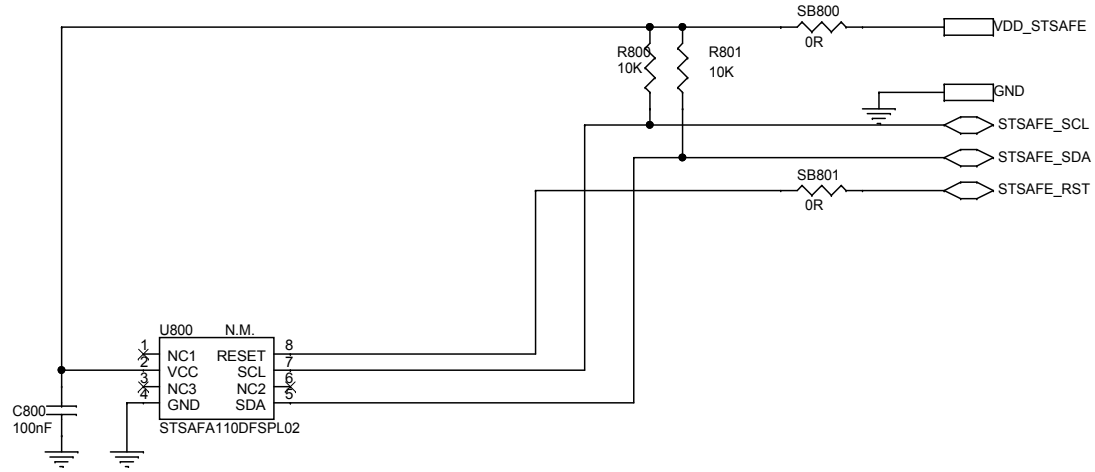

Figure 10. System on board (STEVAL-ASTRA1SB) circuit schematic (1 of 10)

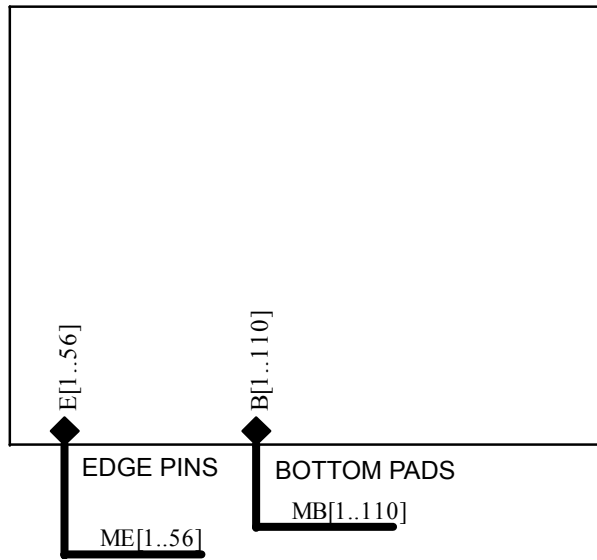

Figure 12. System on board (STEVAL-ASTRA1SB) circuit schematic (3 of 10)

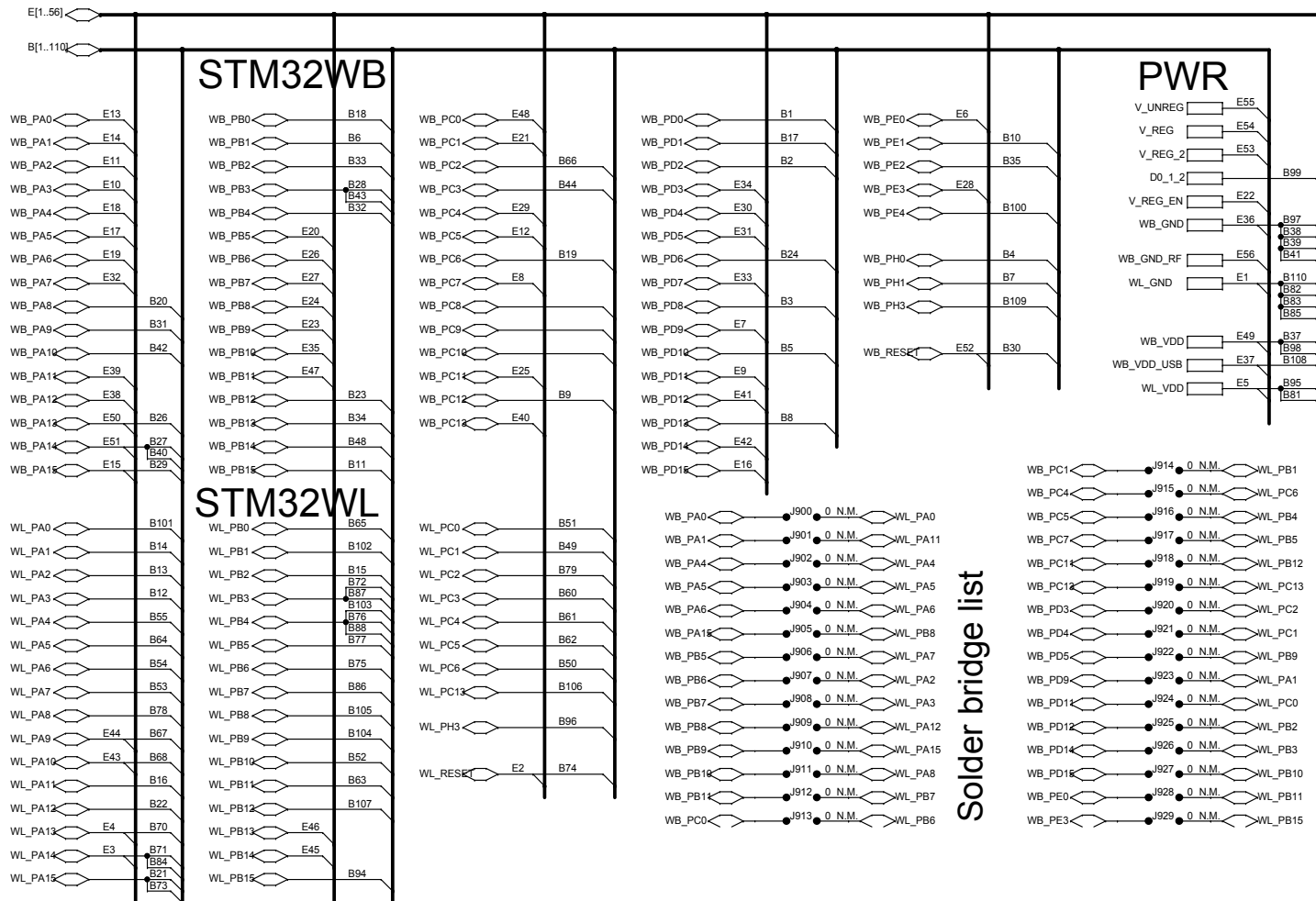
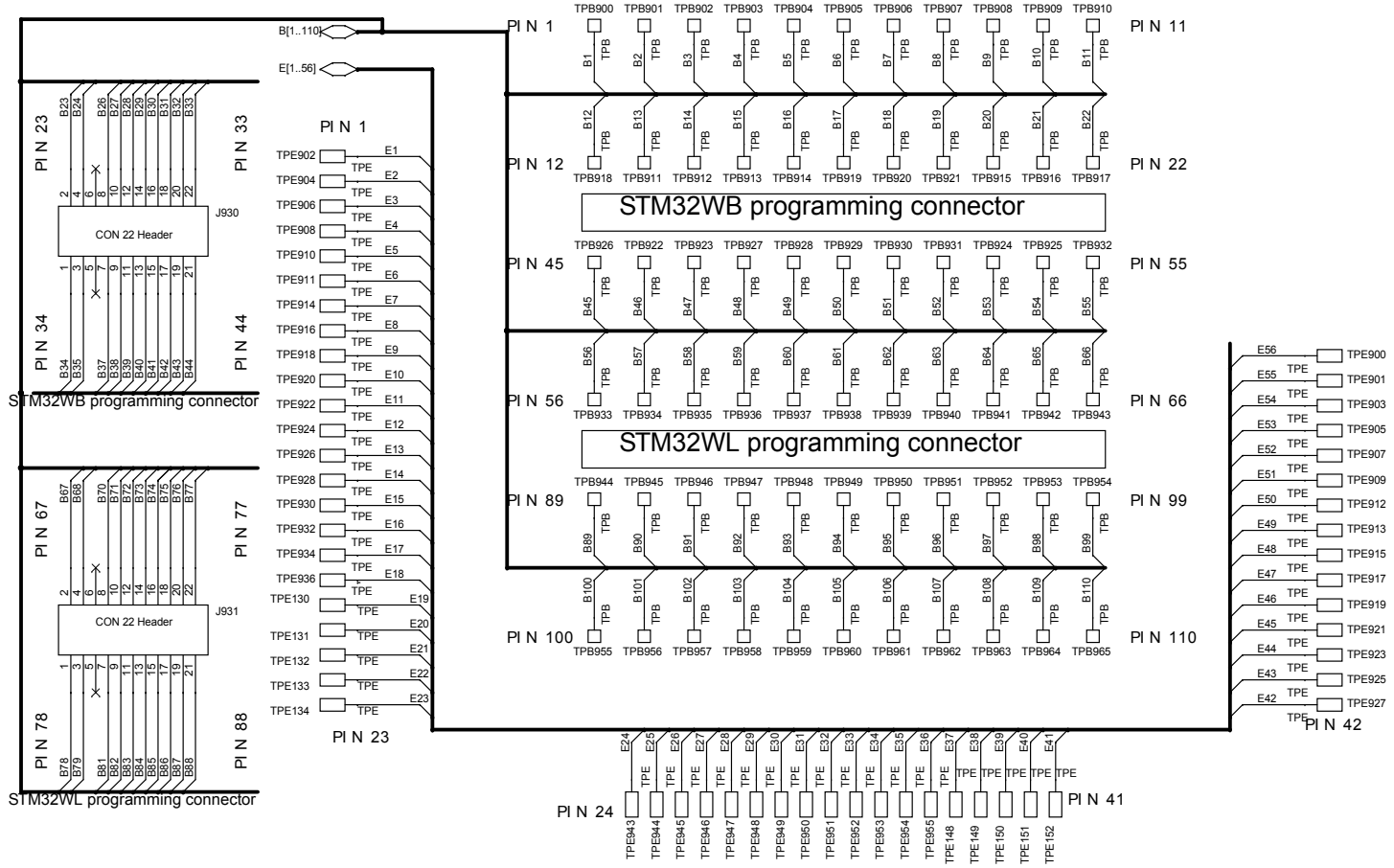

Figure 13. System on board (STEVAL-ASTRA1SB) circuit schematic (4 of 10)



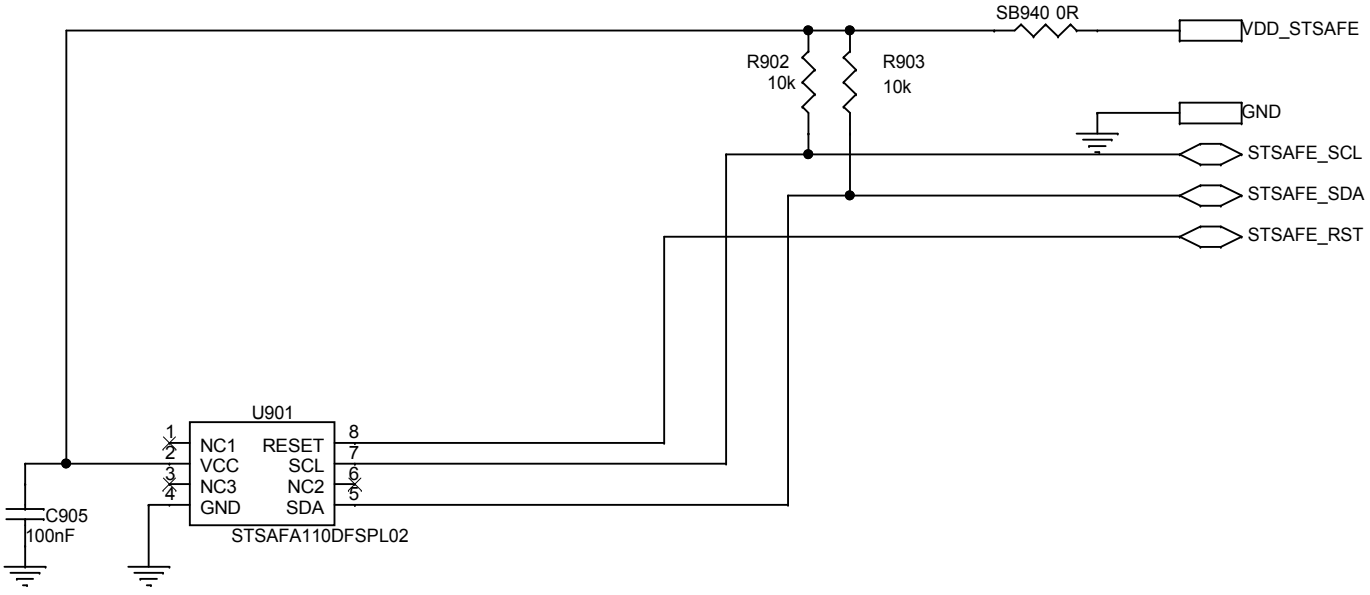

Figure 16. System on board (STEVAL-ASTRA1SB) circuit schematic (7 of 10)



Figure 17. System on board (STEVAL-ASTRA1SB) circuit schematic (8 of 10)

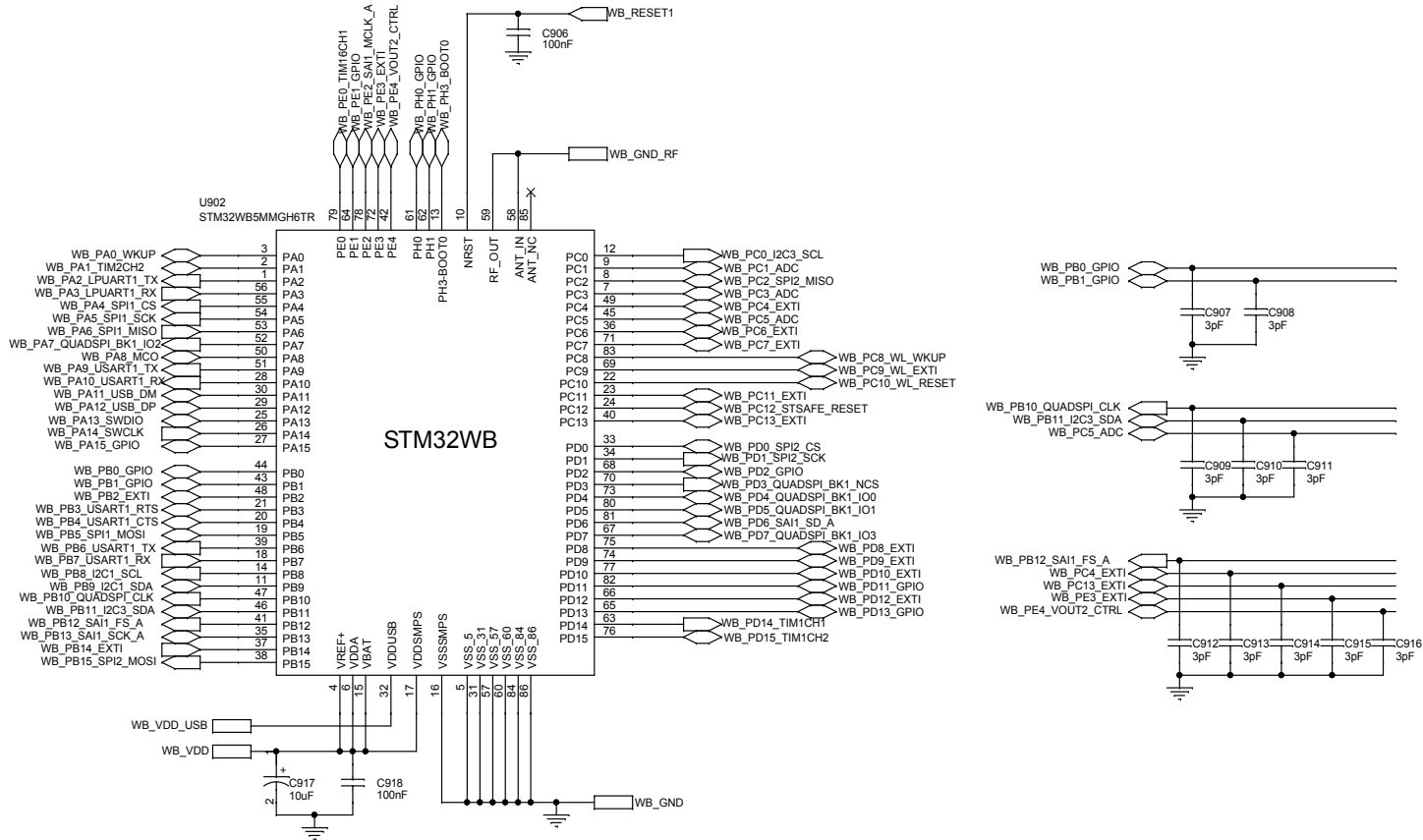

Figure 18. System on board (STEVAL-ASTRA1SB) circuit schematic (9 of 10)

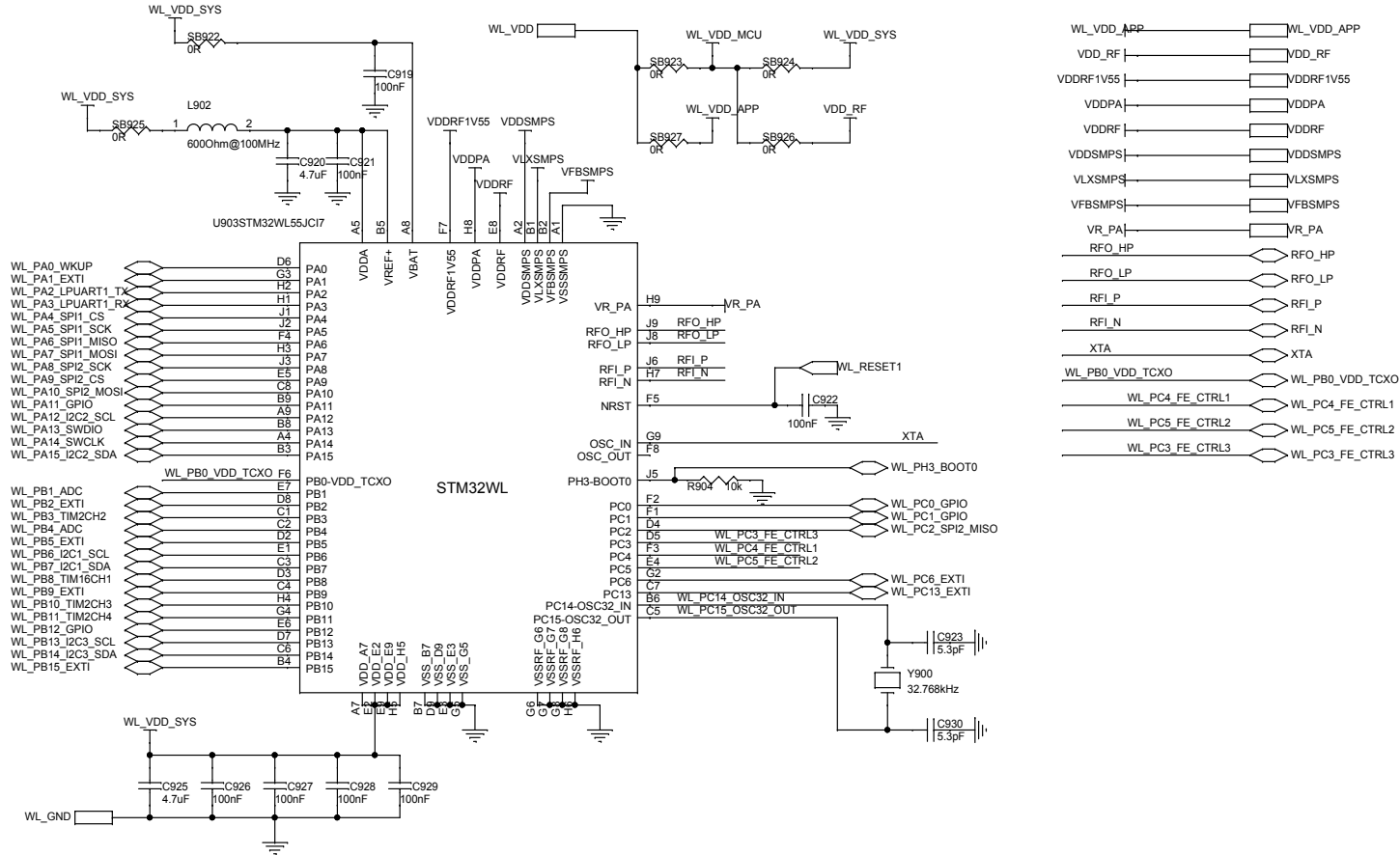

Figure 19. System on board (STEVAL-ASTRA1SB) circuit schematic (10 of 10)

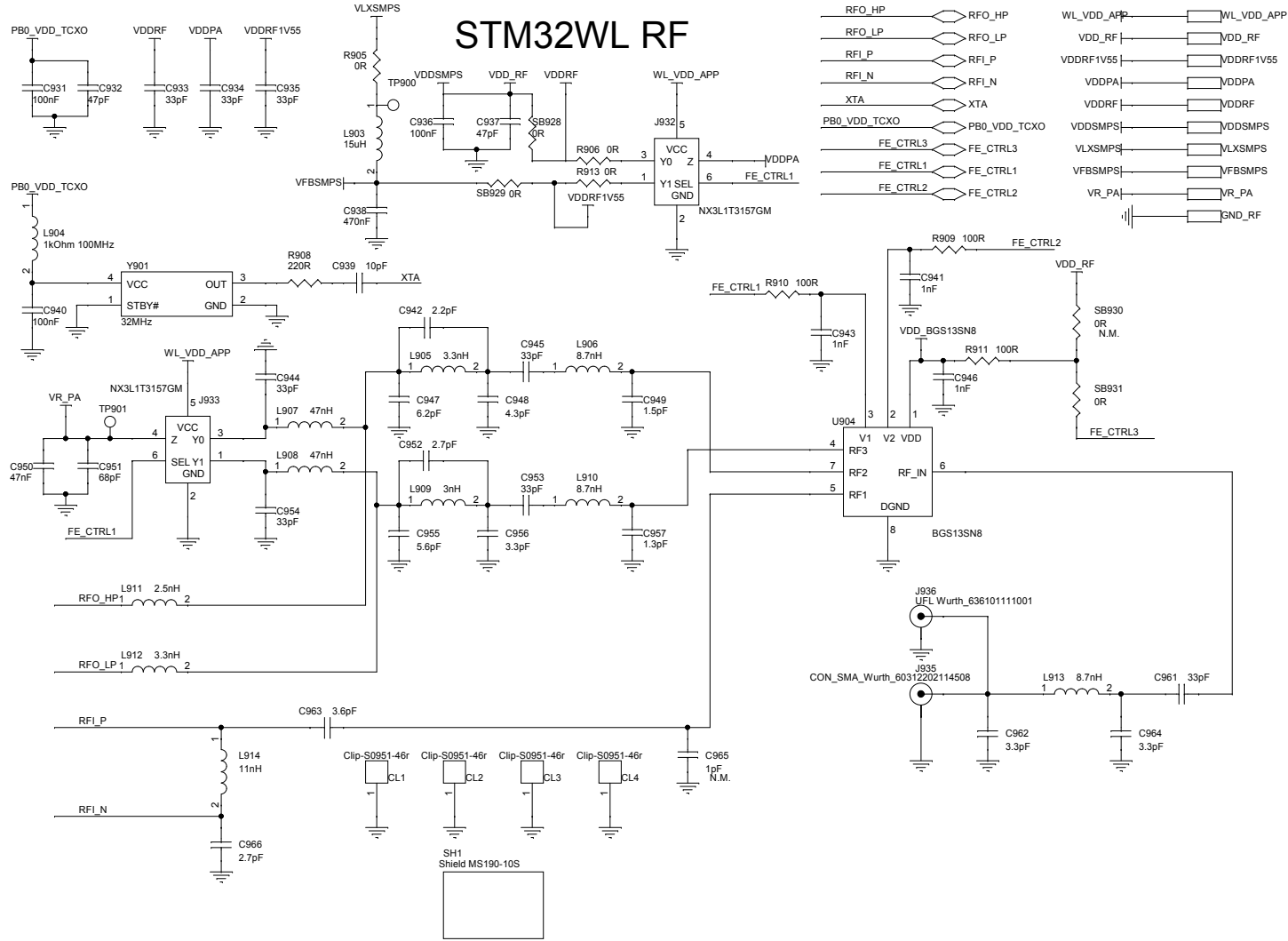

Figure 20. Expansion board (STEVAL-ASTRA1BC) circuit schematic (1 of 5)

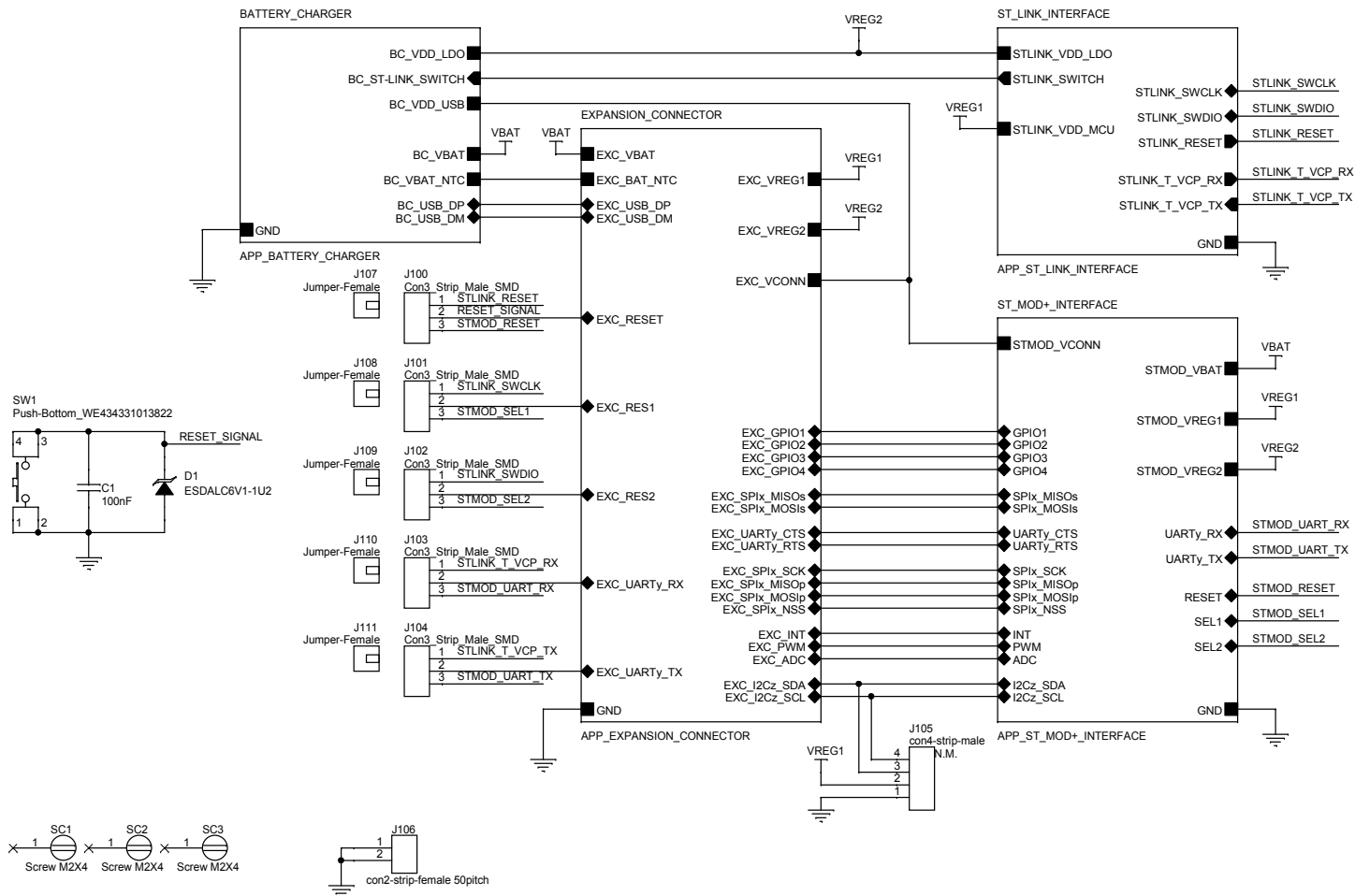

Figure 22. Expansion board (STEVAL-ASTRA1BC) circuit schematic (3 of 5)

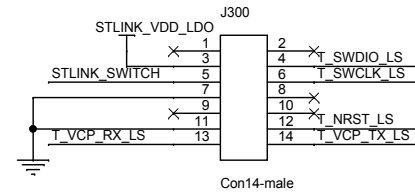
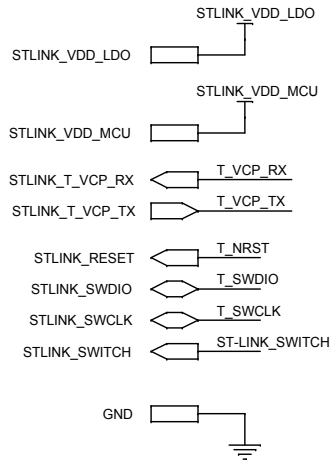
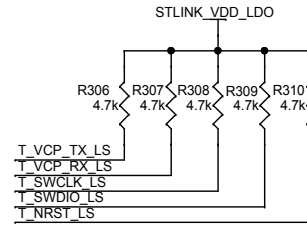
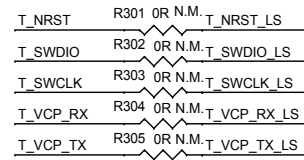
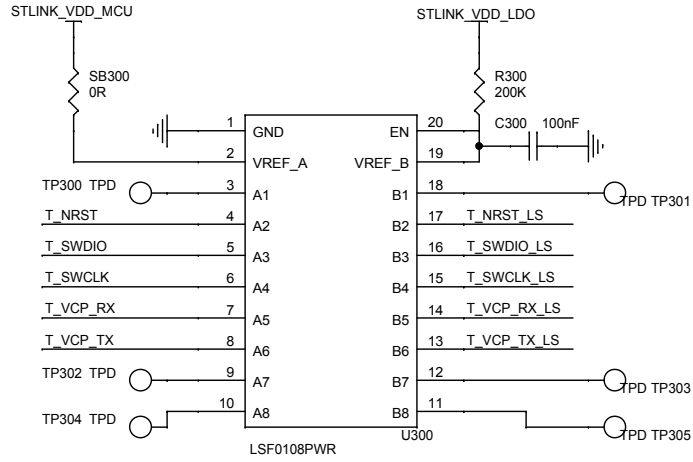

Figure 23. Expansion board (STEVAL-ASTRA1BC) circuit schematic (4 of 5)

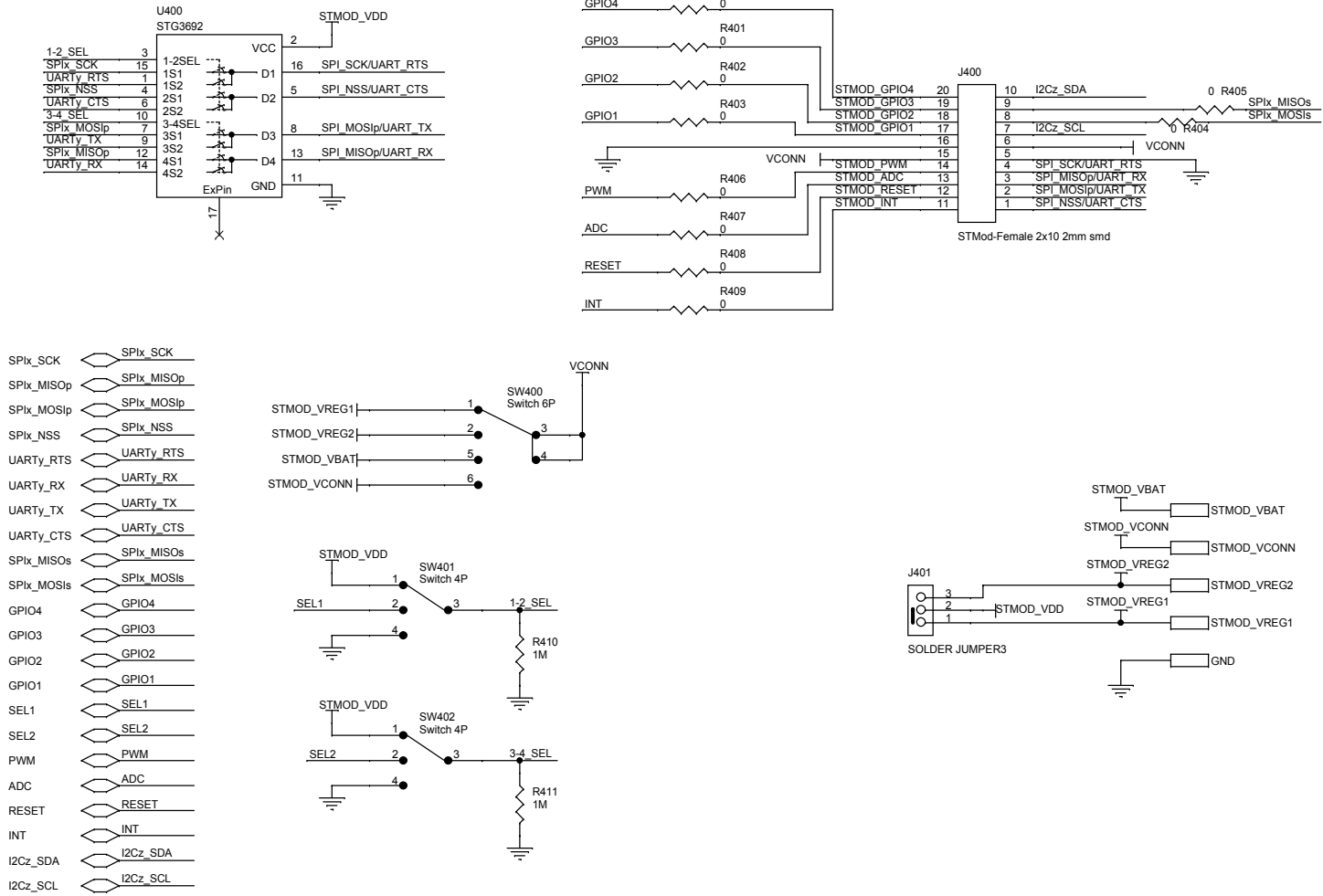

Figure 24. Expansion board (STEVAL-ASTRA1BC) circuit schematic (5 of 5)

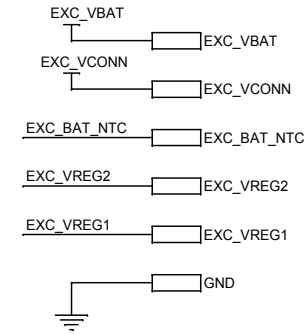
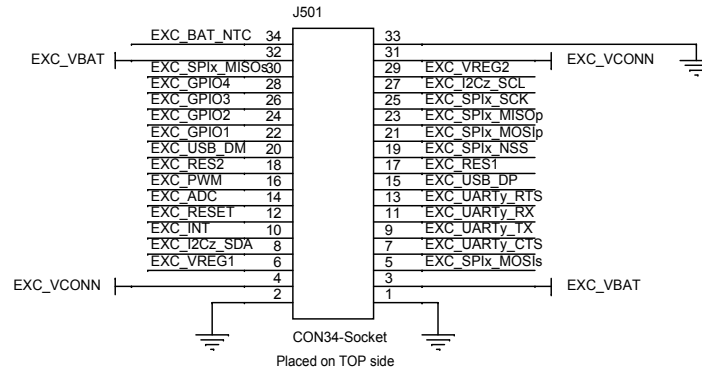
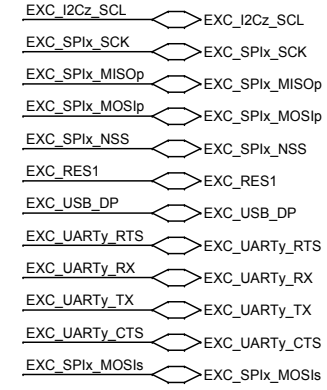
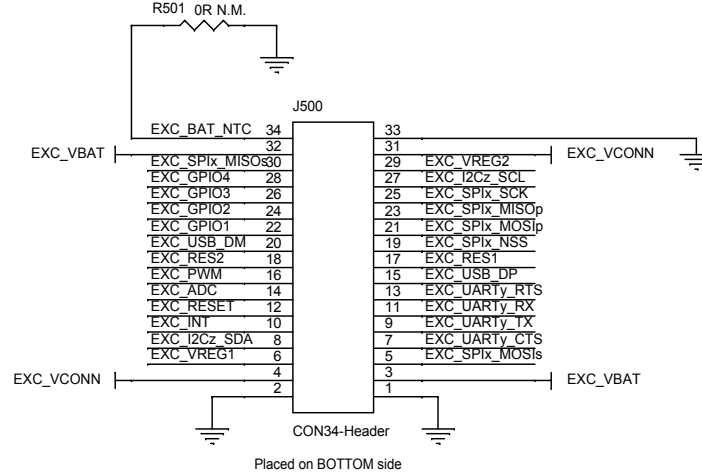
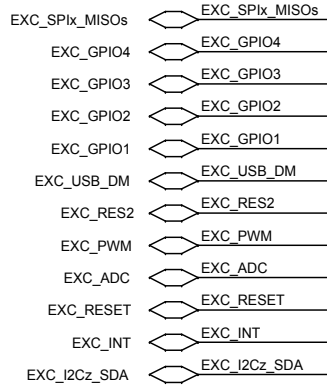
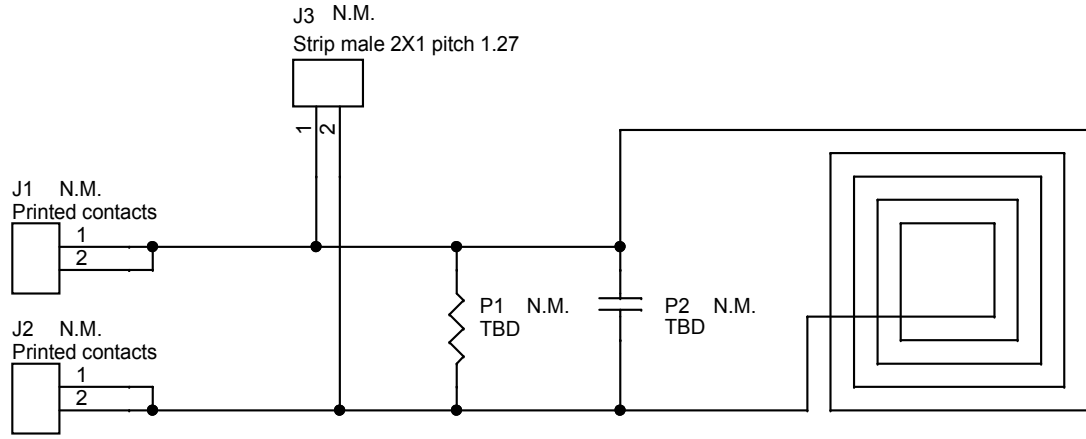

Figure 25. Flexible NFC antenna (STEVAL-ASTRA1NA) circuit schematic



3 Kit versions

Table 1. STEVAL-ASTRA1B kit versions

Finished good	Schematic diagrams	Bill of materials
STEVAL\$ASTRA1BA ⁽¹⁾	STEVAL\$ASTRA1BA schematic diagrams	STEVAL\$ASTRA1BA bill of materials

1. This code identifies the STEVAL-ASTRA1B evaluation kit first version. The kit consist of the STEVAL-ASTRA1 main board, whose version is identified by the code STEVAL\$ASTRA1A, the STEVAL-ASTRA1SB system on board, whose version is identified by the code STEVAL\$ASTRA1SBA, the STEVAL-ASTRA1BC expansion board, whose version is identified by the code STEVAL\$ASTRA1BCA and the STEVAL-ASTRA1NA flexible NFC antenna, whose version is identified by the code STEVAL\$ASTRA1NAA.

Revision history

Table 2. Document revision history

Date	Revision	Changes
17-Feb-2022	1	Initial release.
11-Mar-2022	2	Updated cover page features, description, product summary table, and Section 2 Schematic diagrams .