

5 kW low voltage high current inverter for industrial motor control applications

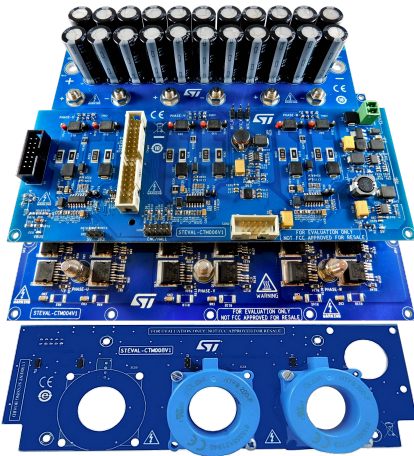

Features

- STEVAL-CTM004V1 (power board)
 - insulated metal substrate (IMS)
 - hosts 36 [STH310N10F7](#) or [STH315N10F7](#) power MOSFETs in the H²PAK-6 (6x switch) package
 - Decoupling gate resistors (2.2 Ω)
 - 3-shunt resistors ground referred for current sensing (optional)
 - 3 NTCs for thermal protection
- STEVAL-CTM005V1 (bulk capacitor board)
 - 22x 270 μF, 100 V through-hole aluminium electrolytic capacitor
- STEVAL-CTM006V1 (driver board)
 - based on 3x [L6491](#) gate driver with current capability up to 4 A sink/source
 - 34-pin MC connector
 - overcurrent, overtemperature and overvoltage protection
- STEVAL-CTM008V1 (current sensing board)
 - accurate phase current sensing
 - DC current sensing (ICS not mounted)
 - possibility of overdriving VREF with an external reference voltage

Description

The [STEVAL-CTM009V1](#) evaluation kit for motor control is designed to demonstrate the capabilities of ST Power MOSFETs based on STripFET™ F7 technology. The 100 V STripFET™ F7 devices (STH31*N10F7) are ideal for low voltage (up to 48 V), high current applications such as forklifts, golf carts and power tool.

The STEVAL-CTM009V1 kit is composed of the STEVAL-CTM004V1, STEVAL-CTM005V1, STEVAL-CTM006V1, STEVAL-CTM008V1 boards which have to be assembled together to build an inverter power stage for three-phase motors.

The STEVAL-CTM004V1 power board features an insulated metal substrate (IMS), NTCs for thermal protection and decoupling gate resistors for each power MOSFET. The board mounts ST devices in the H²PAK-6 package.

The driver stage is an STEVAL-CTM006V1 board with [L6491](#) high current capability gate drivers to drive the power MOSFETs and integrated comparator for protections. The driver board includes the ST motor control connector, so you can interface the STEVAL-CTM009V1 with any ST MCU control board suitable for motor control (not included in the kit).

The system also has an STEVAL-CTM005V1 bus link capacitor board used to connect the 48 V_{DC} power source (e.g. the battery) to manage the ripple current and an STEVAL-CTM008V1 current sensing board to read the three-phase currents and DC bus current (not assembled) thanks to the on-board ICS. The internal reference for the ICSs can be overridden by providing an external reference voltage.

Product summary	
Low voltage high current inverter for industrial motor control applications	STEVAL-CTM009V1
N-channel 100 V, 1.9 mOhm typ., 180 A STripFET F7 Power MOSFET in H ² PAK-6 package	STH310N10F7-6
Automotive-grade N-channel 100 V, 2.1 mOhm typ., 180 A STripFET F7 Power MOSFET in H ² PAK-6 package	STH315N10F7-6
High and low-side 4 A gate driver	L6491

1 STEVAL-CTM0091 kit schematic diagrams

1.1 STEVAL-CTM004V1 schematic diagram

Figure 1. STEVAL-CTM004V1 power board schematic

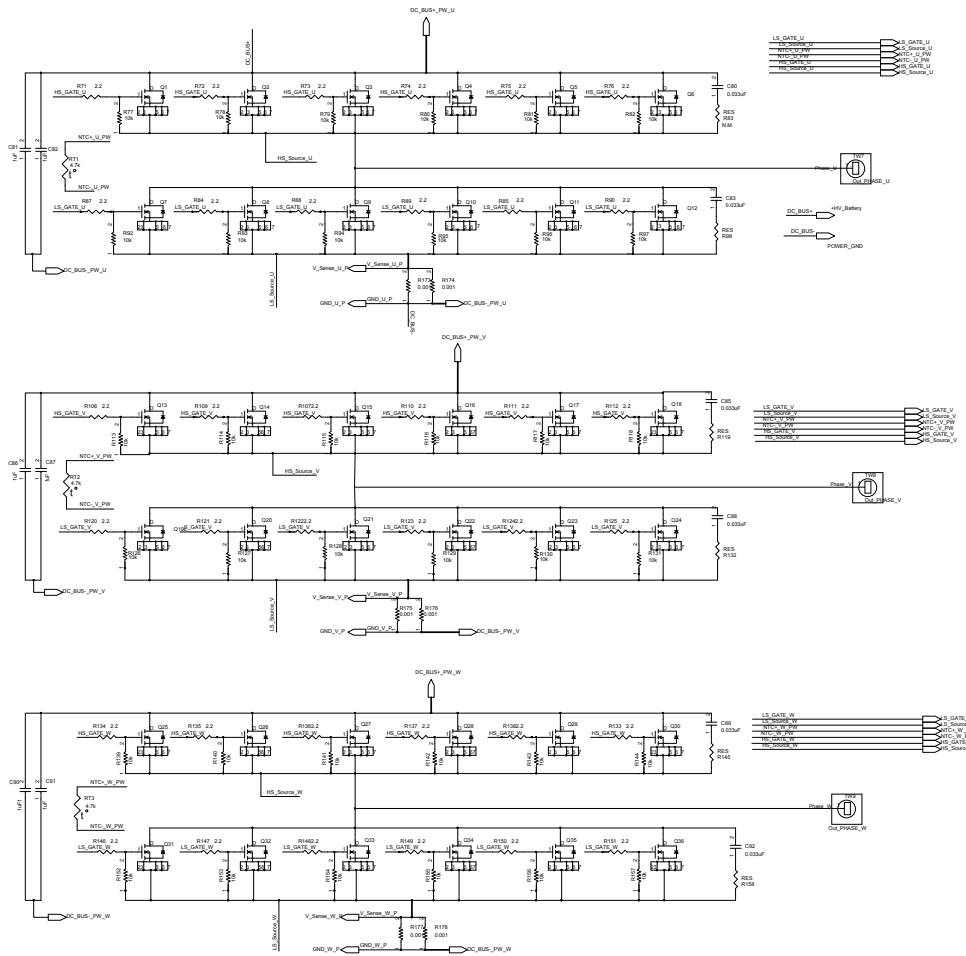

1.2 STEVAL-CTM005V1 schematic diagram

Figure 2. STEVAL-CTM005V1 capacitor board schematic

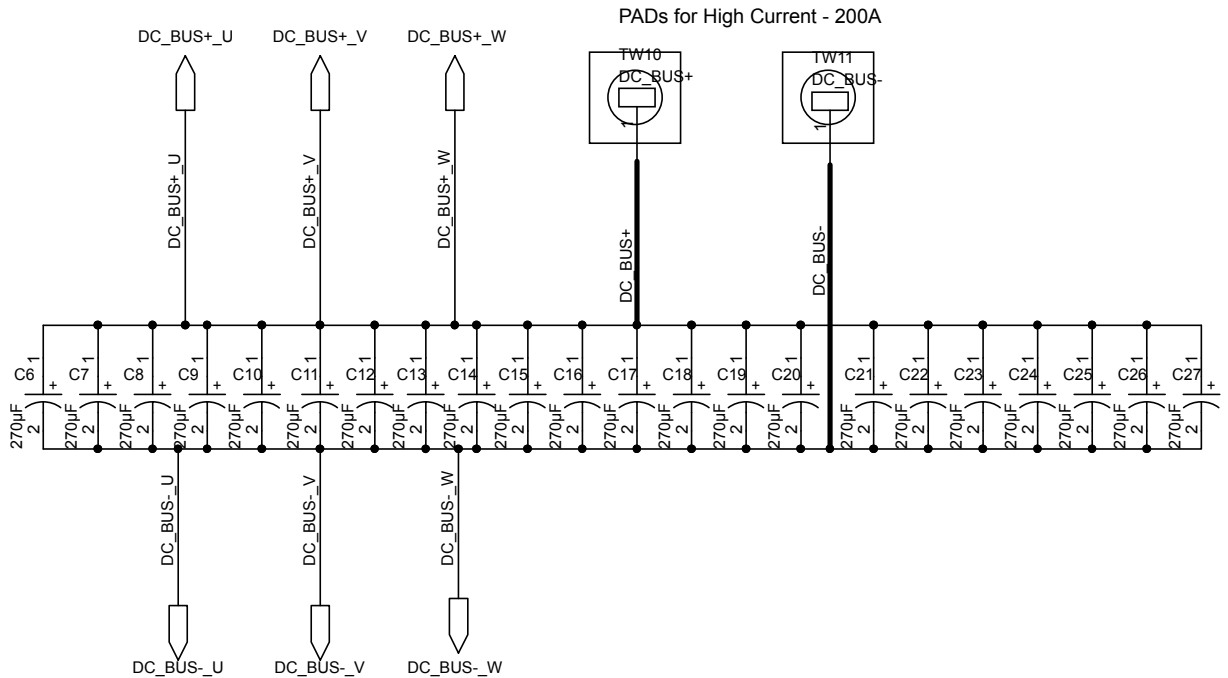

1.3 STEVAL-CTM006V1 schematic diagrams

Figure 3. STEVAL-CTM006V1 driver board schematic - main

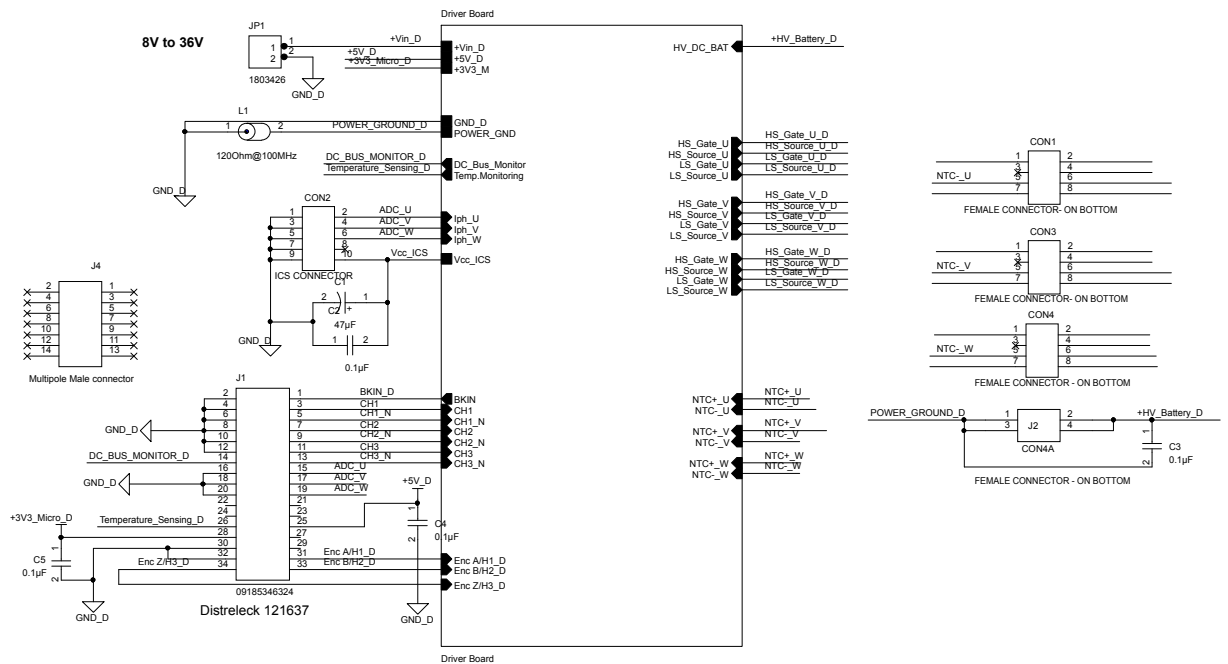

Figure 4. STEVAL-CTM006V1 driver board schematic - sensing

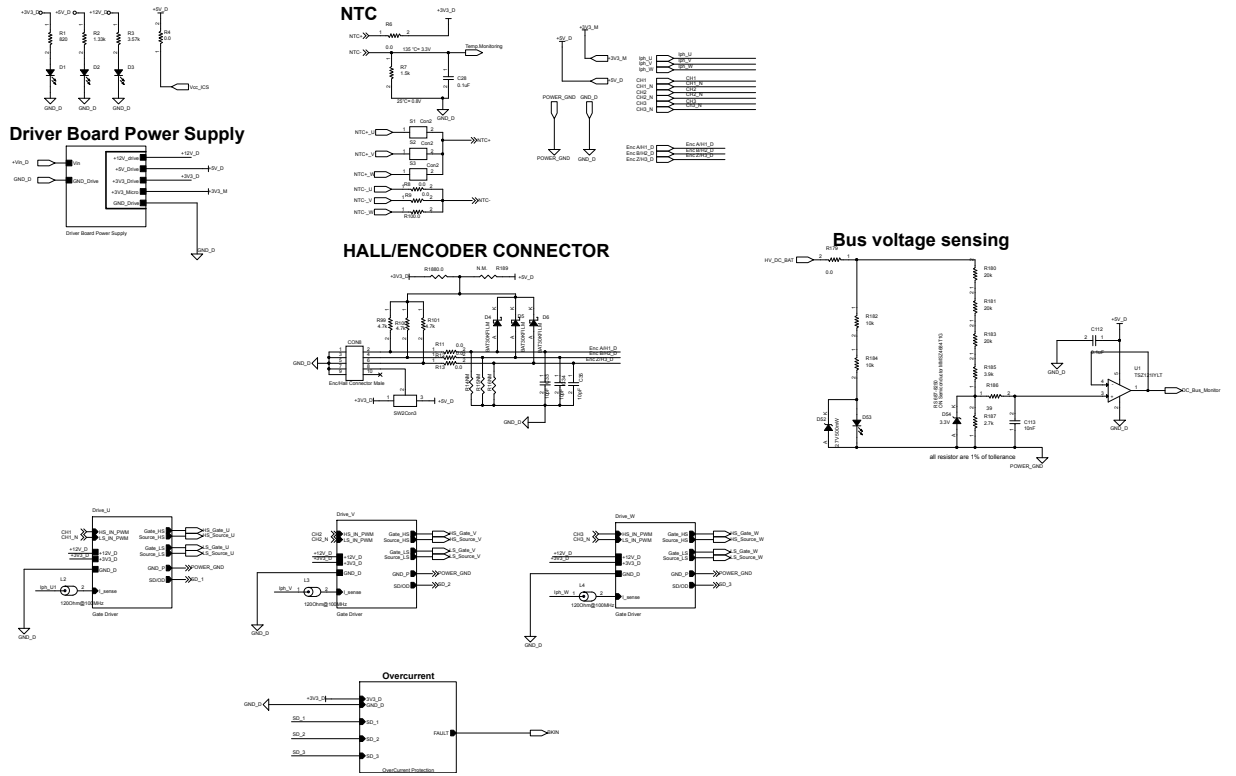

Figure 5. STEVAL-CTM006V1 driver board schematic - gate drivers

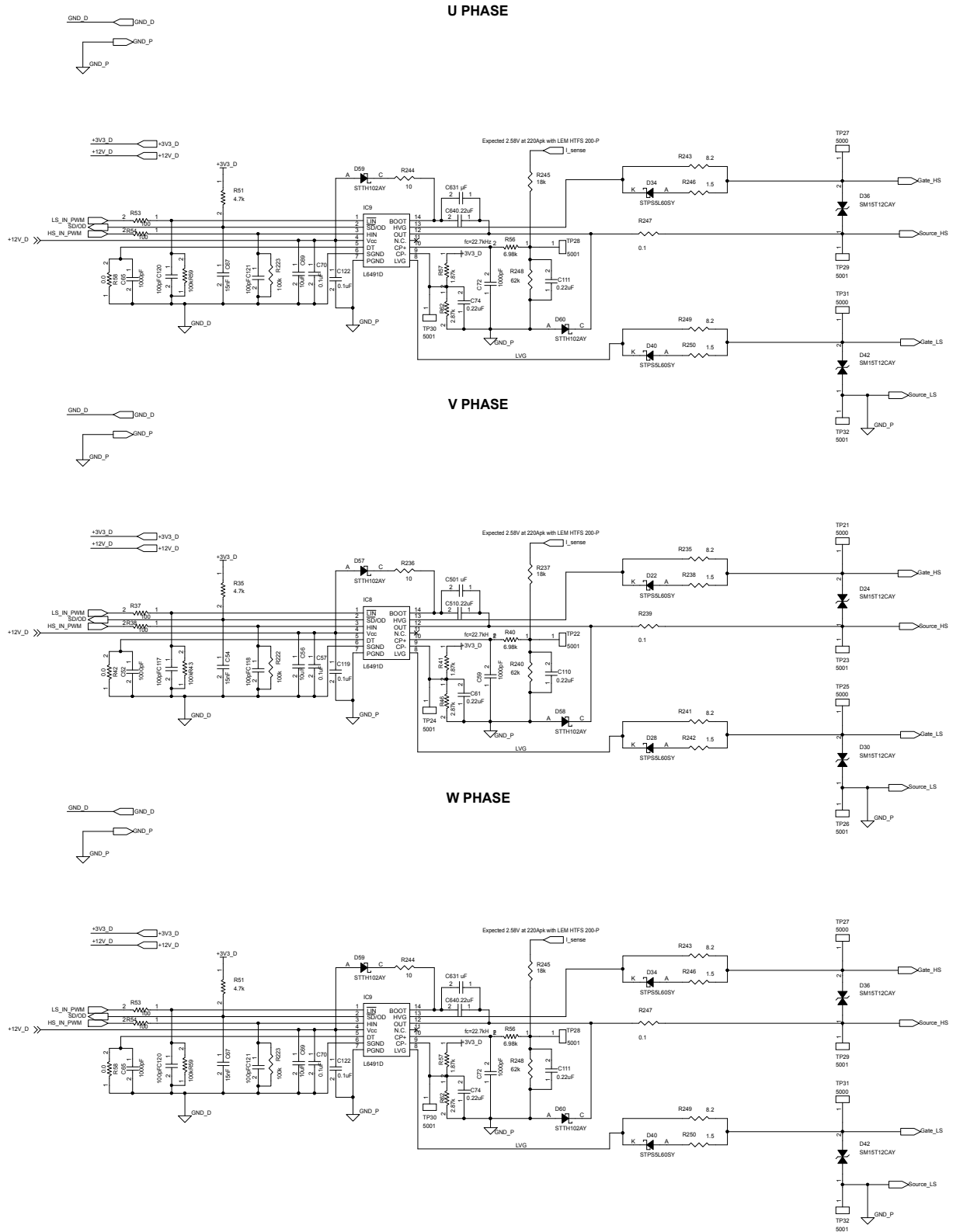

Figure 6. STEVAL-CTM006V1 driver board schematic - overcurrent protection

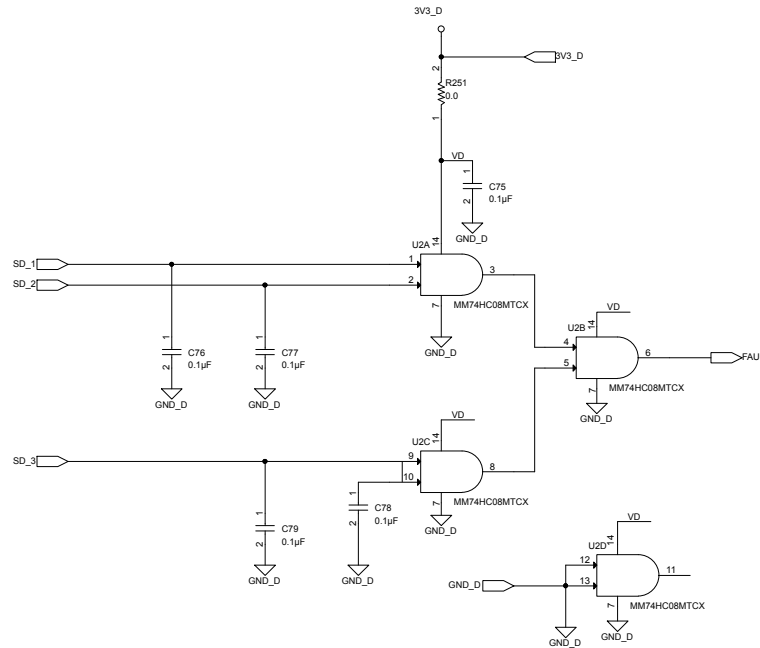
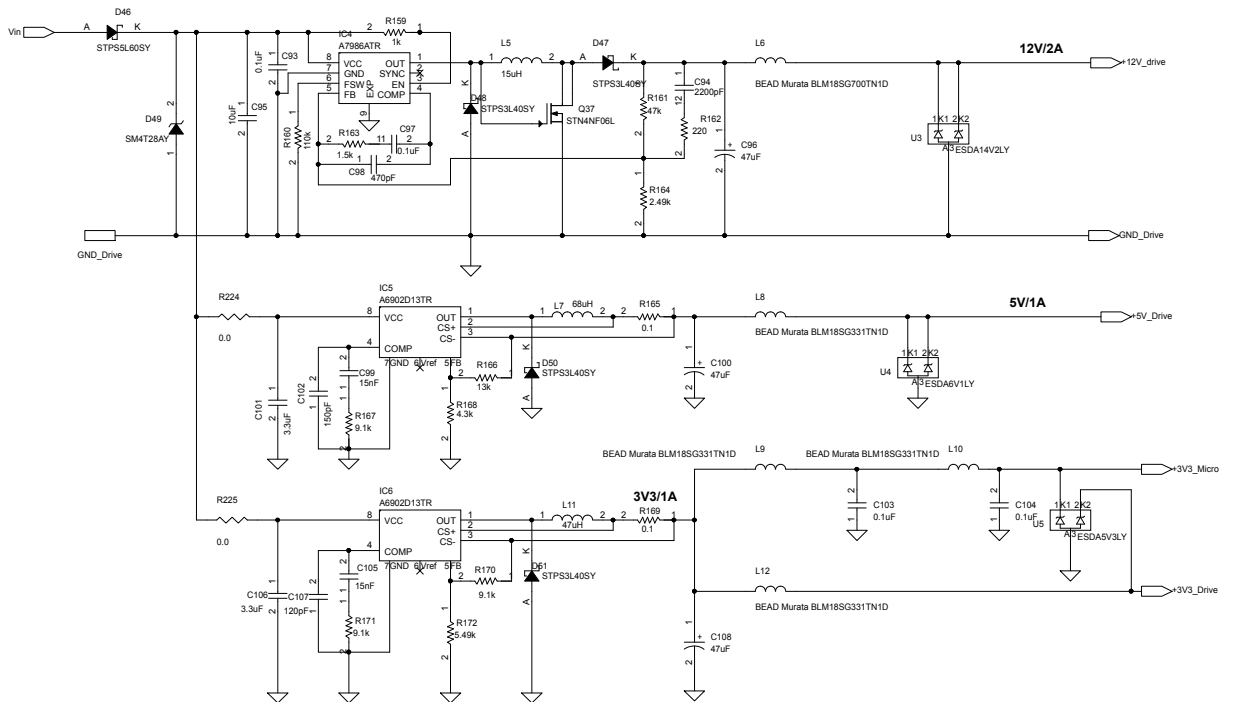
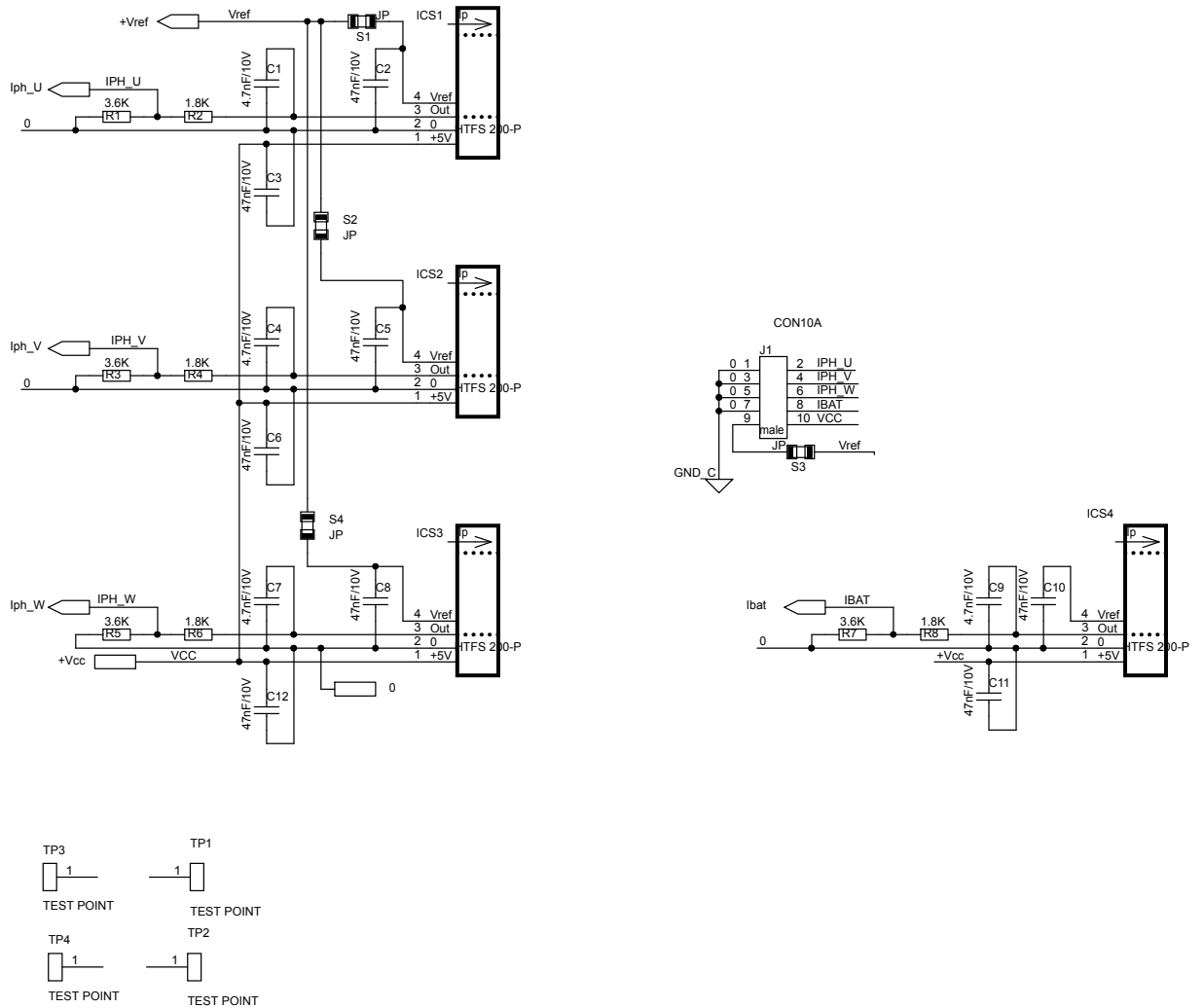

Figure 7. STEVAL-CTM006V1 driver board schematic - power supply



1.4 STEVAL-CTM008V1 schematic diagram

Figure 8. STEVAL-CTM008V1 current sensing board schematic



Revision history

Table 1. Document revision history

Date	Version	Changes
20-Aug-2018	1	Initial release.
16-Oct-2018	2	Updated cover page image.