

1.5 kW dual motor drive with digital PFC based on SLLIMM™ IPMs and STM32F3

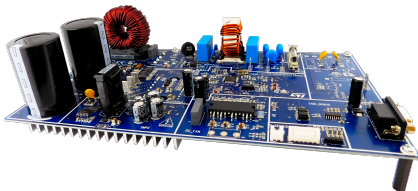

Features

Features

- Input voltage: 230 V_{AC} 50 Hz / 60 Hz
- Max. power: up to 2 kW
- PFC topology: digital control, boost single stage
- PFC protections: overcurrent, overvoltage, and undervoltage lockout
- Inrush current limiter based on overvoltage protected AC switch
- Motor 1 stage:
 - STGIB10CH60TS-L, SLLIMM series IPM 15 A, 600 V, 3-phase IGBT inverter bridge
 - Max. current: up to 10 A, 0-to-peak (current sensing network threshold)
 - 1-, 2-, and 3-shunt resistors for current sensing
 - Protections: overcurrent, overtemperature, undervoltage lockout
- Motor 2 stage:
 - STGIPQ3H60T-HZ SLLIMM nano series IPM, 3 A, 600 V, 3-phase IGBT inverter bridge
 - Max. power: 60 W (no heatsink)
 - Max. current: up to 1 A, 0-to-peak (current sensor network threshold)
 - 1 shunt resistor for current sensing
 - Protections: overcurrent, overtemperature, undervoltage lockout
- Centralized driving (motor 1, motor 2, PFC) from single STM32F303RB MCU based on ARM Cortex-M4 core with DSP and FPU
- WEEE and RoHS compliant

Description

The STEVAL-CTM010V1 board embeds two sensorless 3-phase motor drives, plus a single stage digital PFC boost topology, all controlled by the [STM32F303RB](#) ARM based microcontroller. The ST FOC MC SDK firmware library enables this complete hardware and software solution, featuring FOC dual motor sensorless and PFC CCM mode. The inverter stages are based on SLLIMM™ IPM series of intelligent power modules for compact, high-performance AC motor drives in a simple, rugged design. It combines new ST proprietary driver ICs with an improved short-circuit rugged trench gate field-stop (TFS) IGBT, making it ideal for motor drives operating up to 20 kHz in hard-switching circuits.

The PFC section is based on the [STTH30AC06C](#) ultra-fast high voltage rectifier and [STGWT20H65FB](#) trench gate field-stop IGBT.

The board embeds the 2nd generation SLLIMM [STGIB10CH60TS-L](#) and [STGIPQ3H60T-HZ](#) intelligent power modules, which are tailored to drive motors for compressors and fans in outdoor units. The [STEVAL-CTM010V1](#) is therefore ideal for evaluating room air conditioner solutions able to meet new efficiency standards requiring digital PFCs, and any single or dual motor application with power factor correction.

Product summary	
1.5 kW dual motor drive with digital PFC based on SLLIMM™ IPMs and STM32F3	STEVAL-CTM010V1
Mainstream mixed signal MCUs ARM® Cortex®-M4 core with DSP and FPU	STM32F303RB
600 V, 30 A dual Interleave Boost Ultrafast Diode	STTH30AC06C
Trench gate field-stop IGBT, HB series 650 V, 20 A high speed	STGWT20H65FB
STGIB10CH60TS-L SLLIMM™ 2nd series IPM	STGIB10CH60TS-L
SLLIMM nano 2nd series IPM, 3 A, 600 V, 3-phase IGBT inverter bridge	STGIPQ3H60T-HZ

1 Schematic diagrams

Figure 1. STEVAL-CTM010V1 block diagram

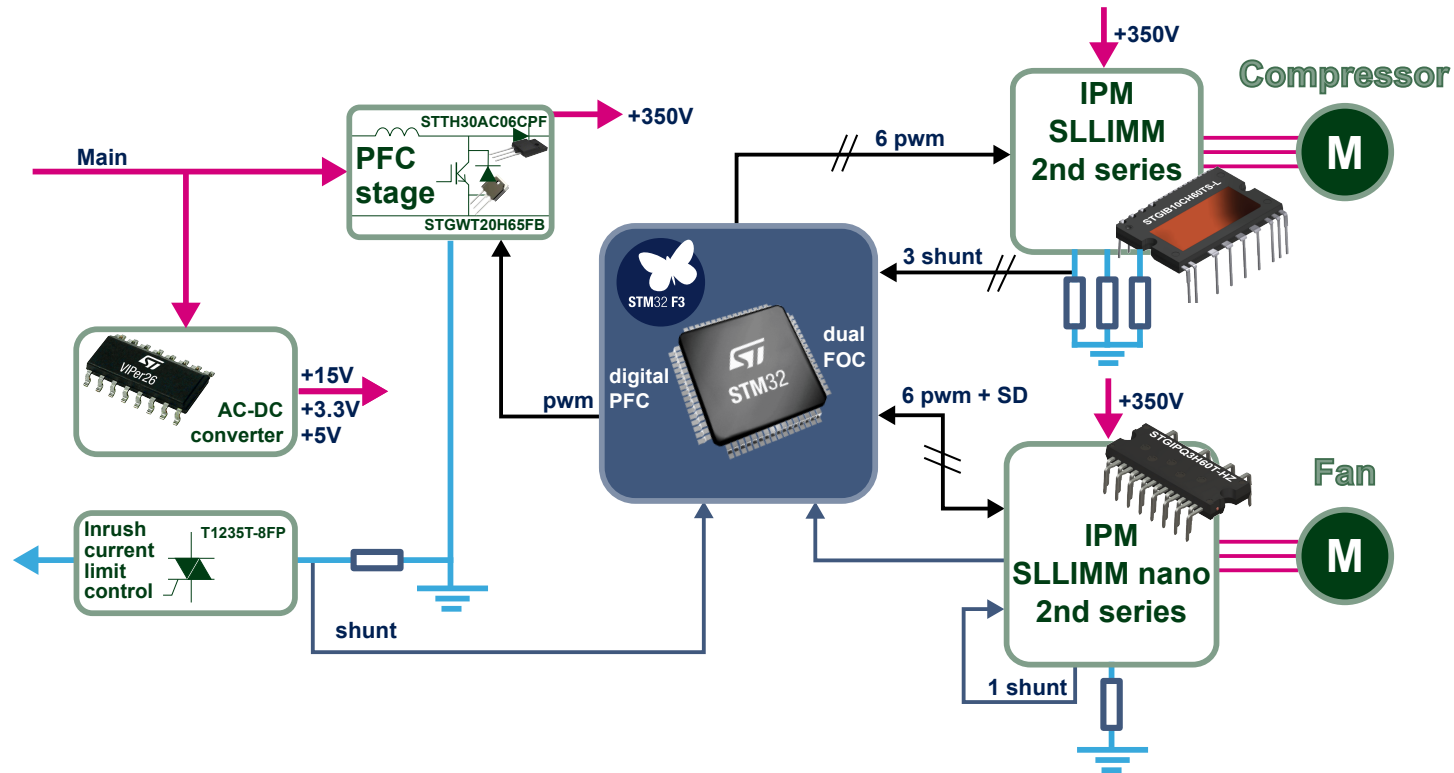

Figure 2. STEVAL-CTM010V1 schematic diagram - SMPS

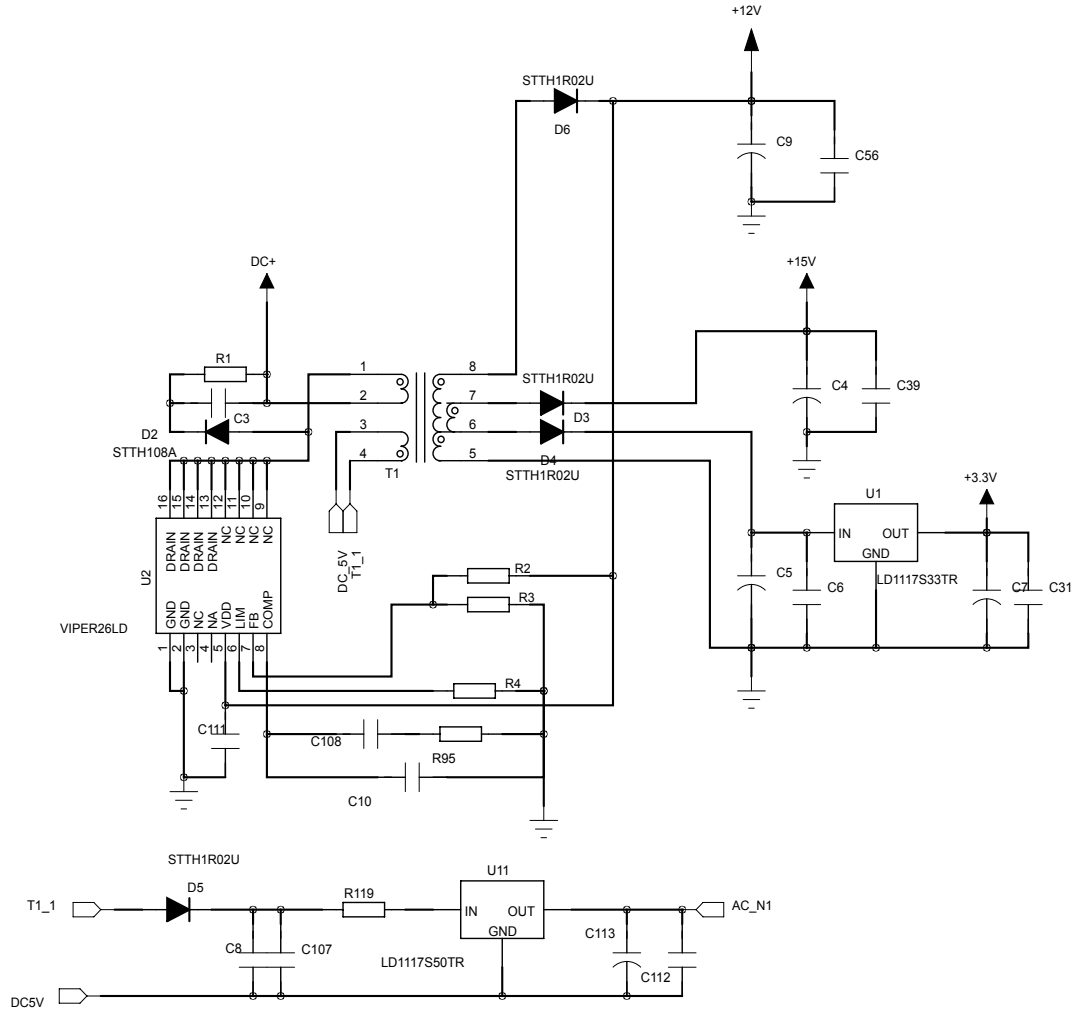

Figure 3. STEVAL-CTM010V1 schematic diagram - EMI and PFC

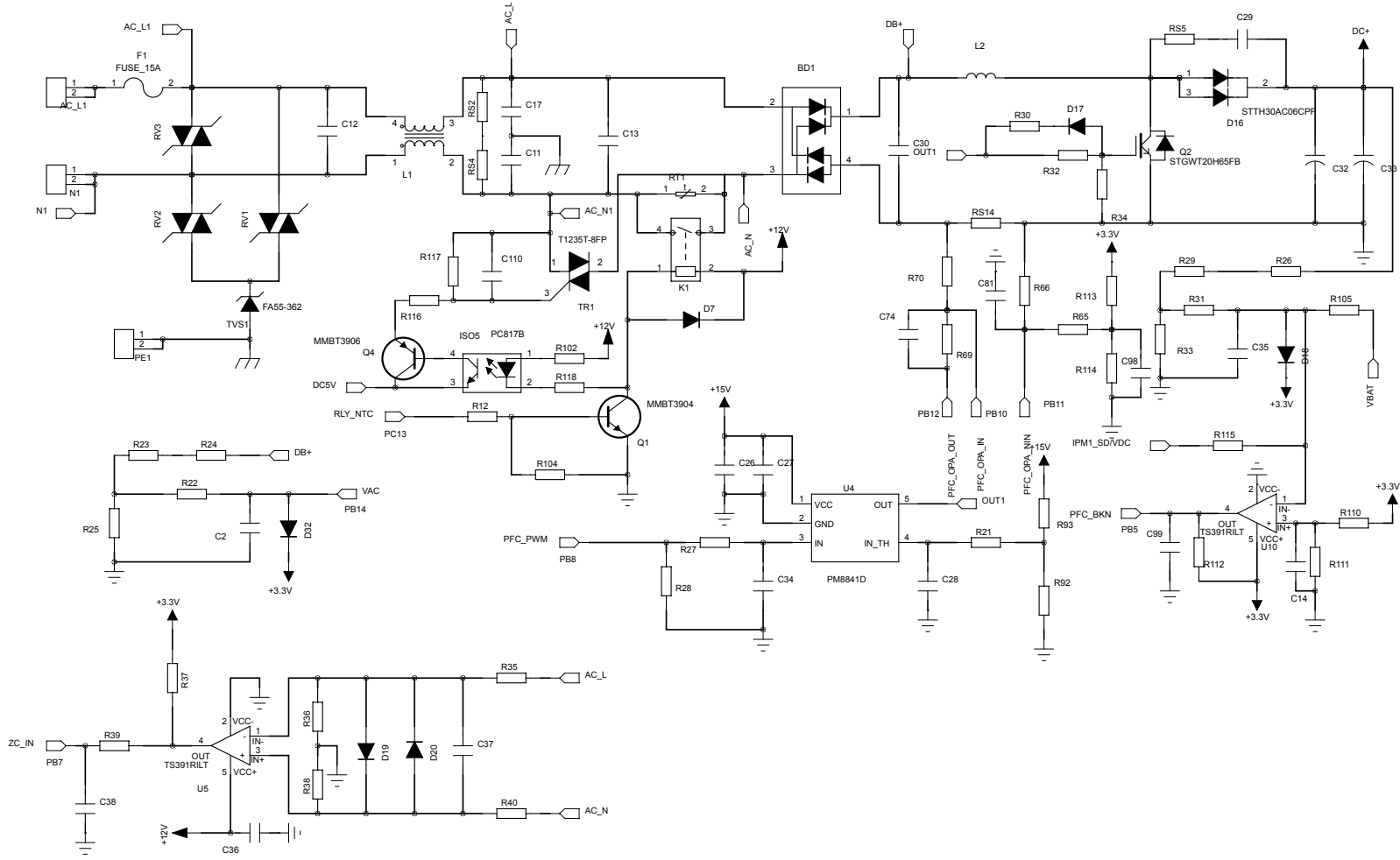

Figure 4. STEVAL-CTM010V1 schematic diagram - IPM1

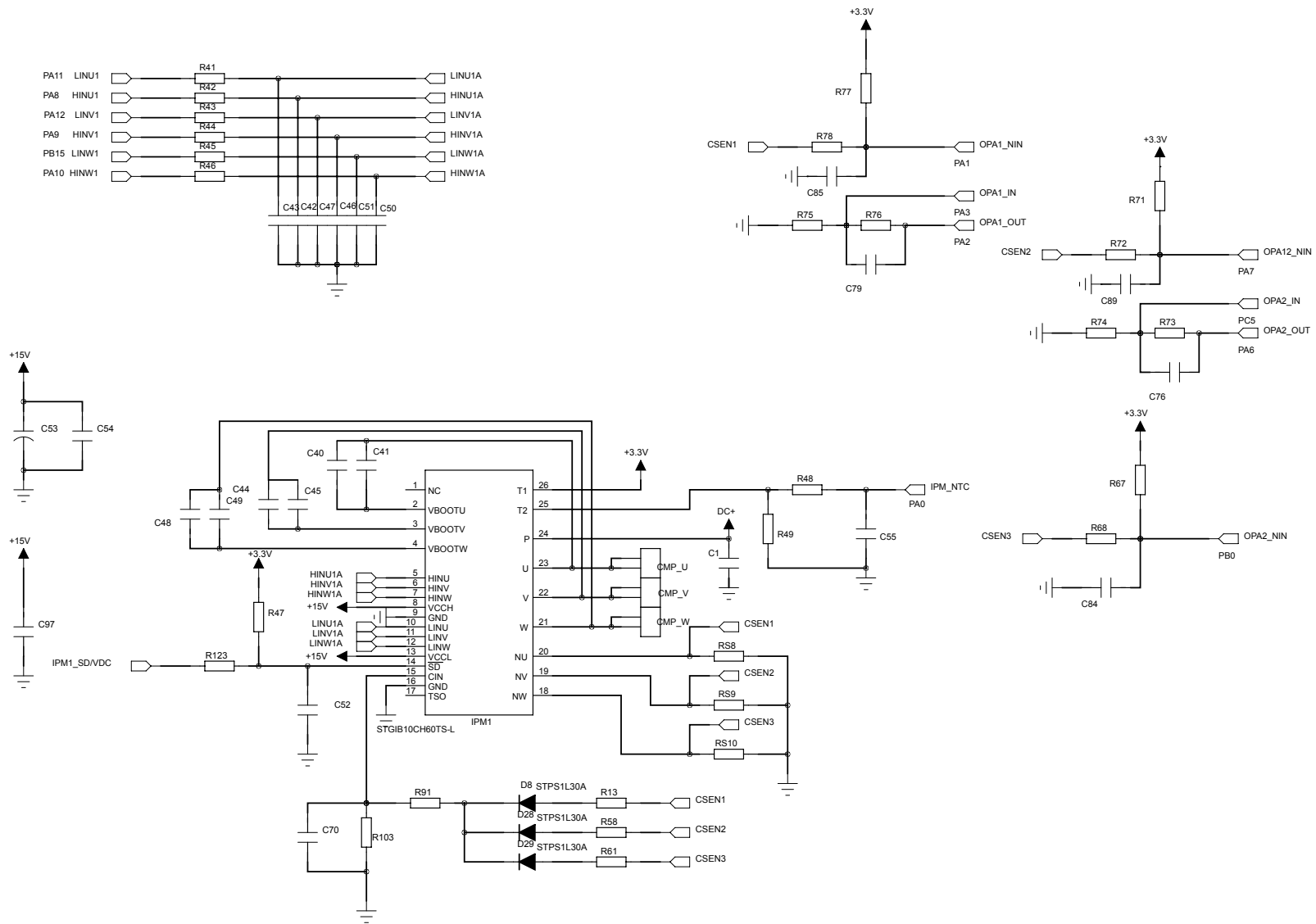

Figure 5. STEVAL-CTM010V1 schematic diagram - IPM2

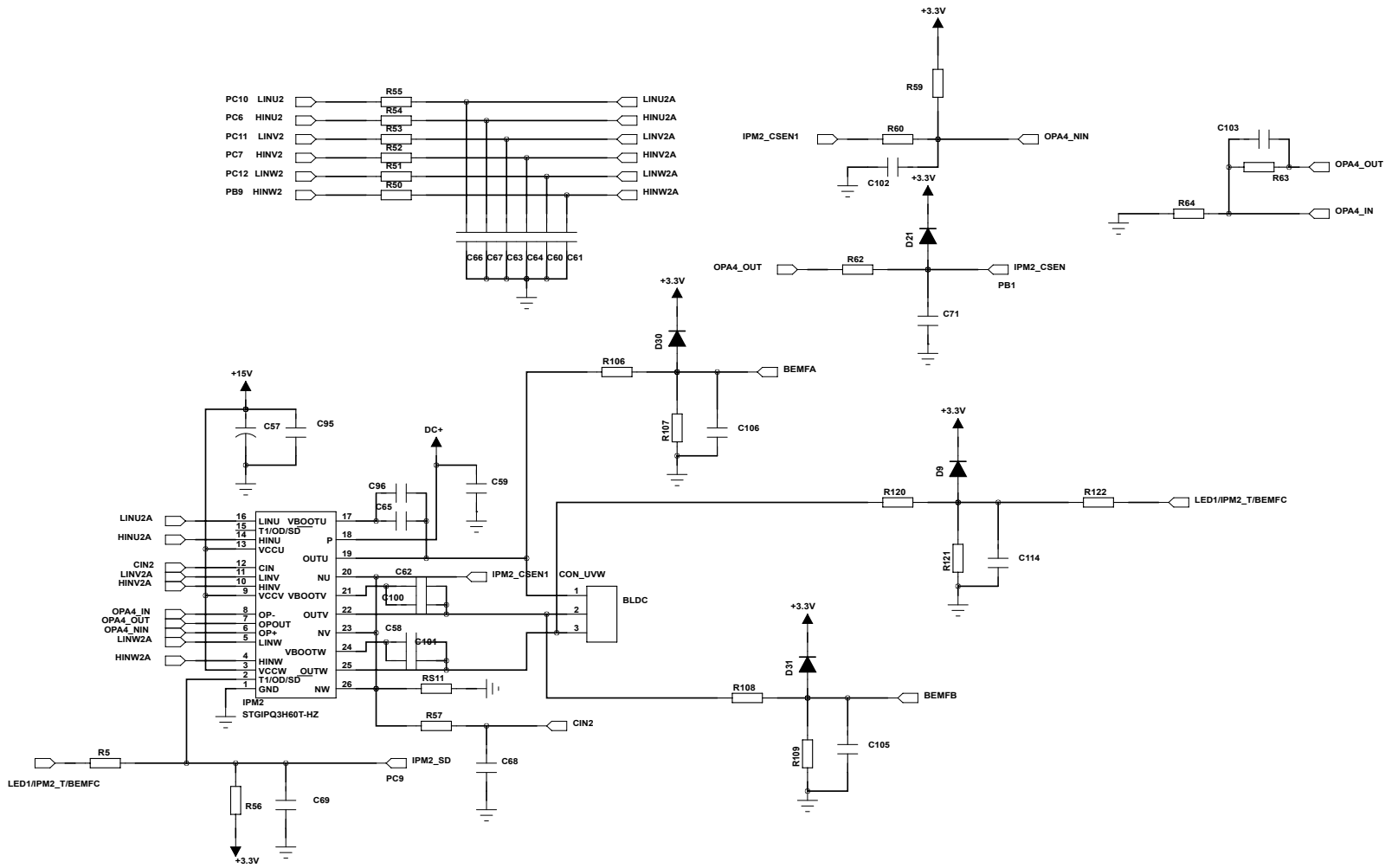

Figure 6. STEVAL-CTM010V1 schematic diagram - MCU

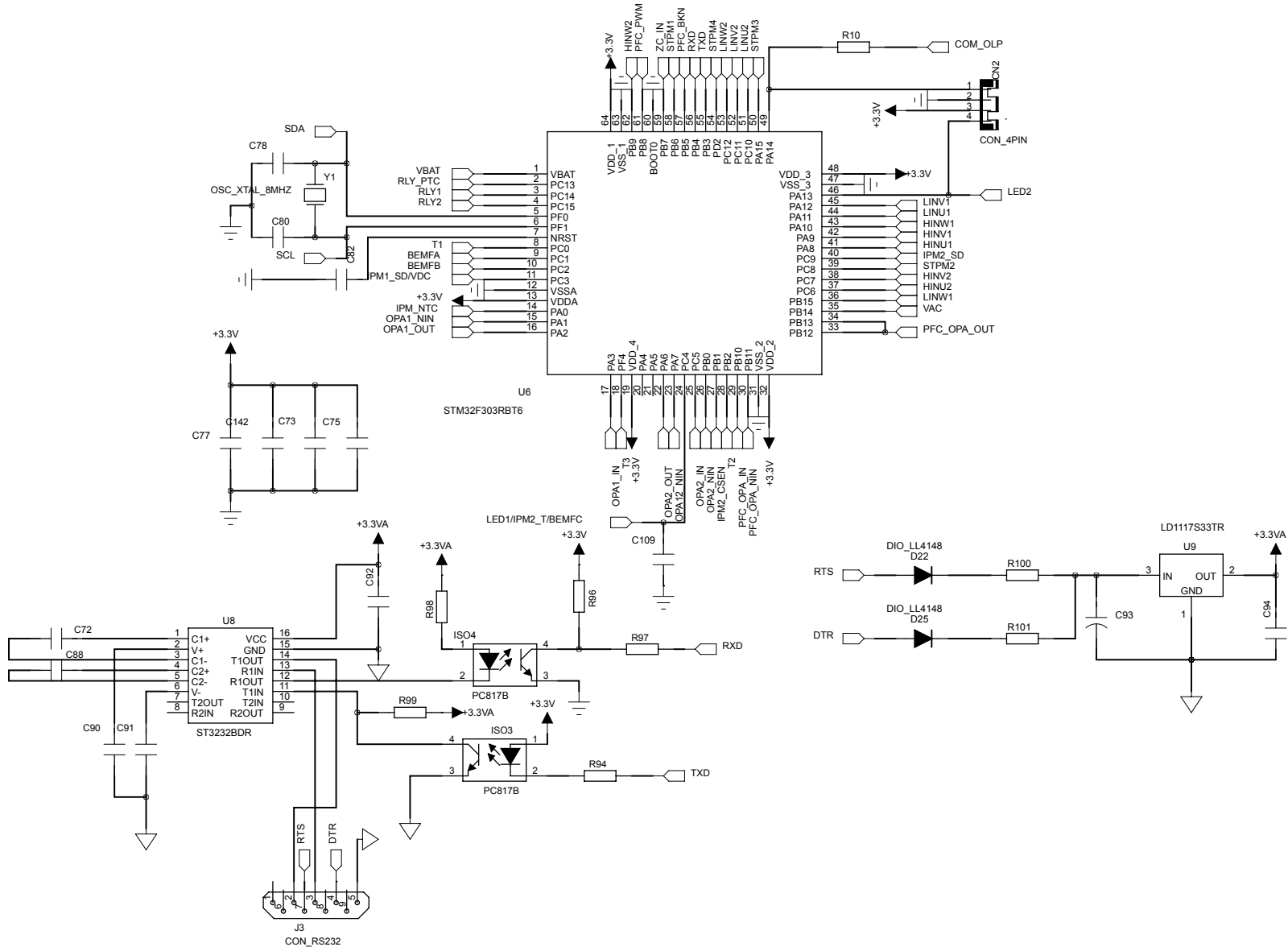
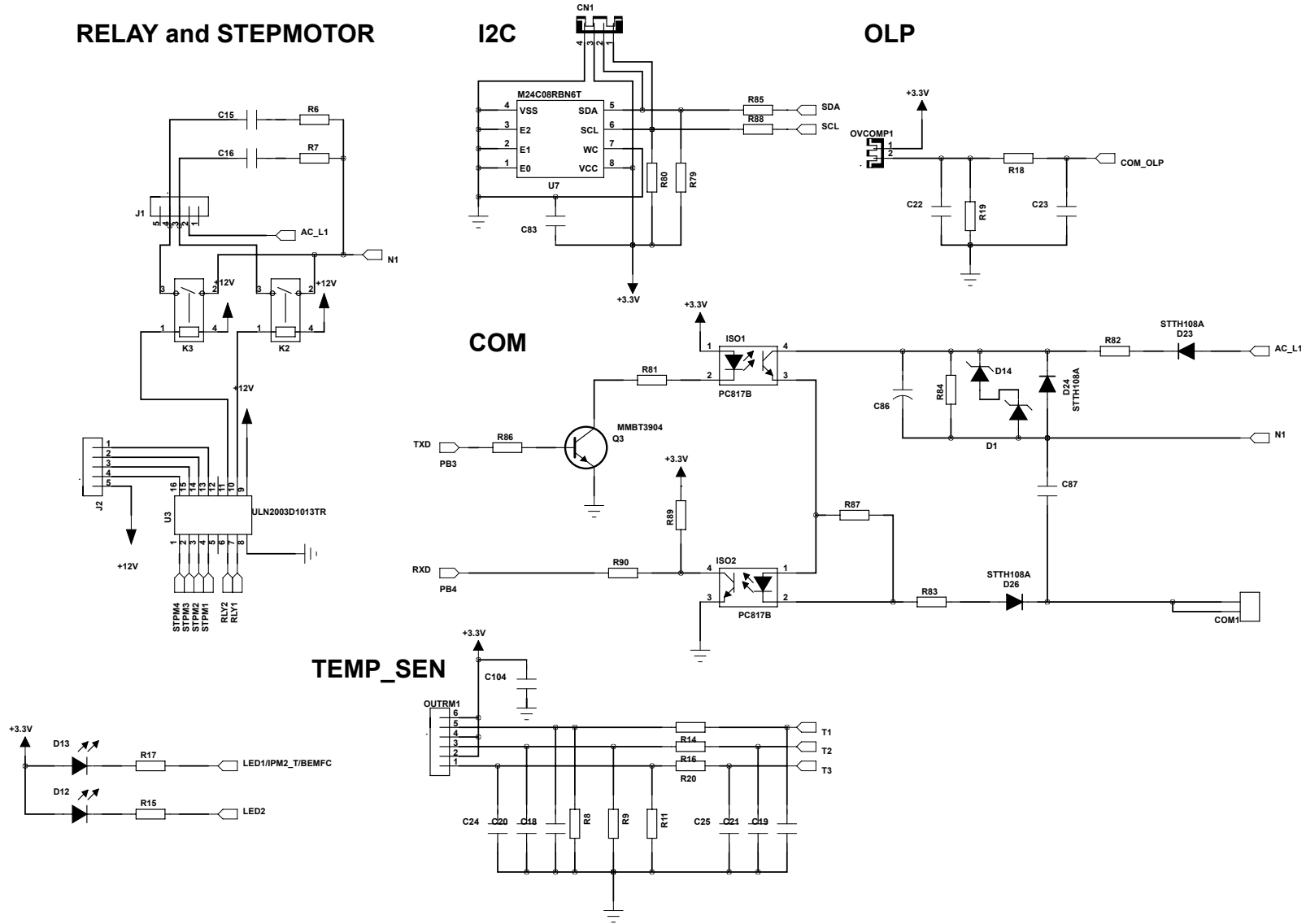

Figure 7. STEVAL-CTM010V1 schematic diagram - miscellaneous



Revision history

Table 1. Document revision history

Date	Version	Changes
12-Mar-2019	1	Initial release.