

3.6 kW Totem Pole PFC with inrush current limiter reference design using TN3050H-12WY and SCTW35N65G2V

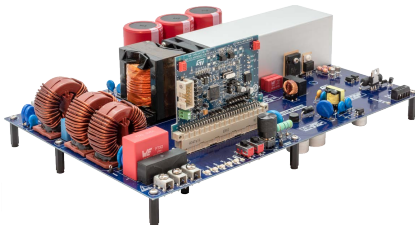

Features

- Peak efficiency: 97.5 % with 3.7% THD
- Compact PFC converter
- Higher switching lifetime
- Compliant with EMI normative at 4 kV
- RoHS and WEEE compliant

Applications

- EV/HEV on-board chargers
- Charging stations
- Motor drive, motion control
- UPS, industrial battery charger
- Server/Telecom SMPS

Description

The **STEVAL-DPSTPFC1** 3.6 kW bridgeless totem pole boost circuit achieves a digital power factor correction (PFC) with inrush current limiter (ICL). It helps you to design an innovative topology with the latest ST power kit devices: a silicon carbide MOSFET (**SCTW35N65G2V**), a thyristor SCR (**TN3050H-12WY**), an isolated FET driver (**STGAP2S**) and a 32-bit MCU (**STM32F334**).

This reference design also opens the path to a compact converter running at 72 kHz offering a high peak efficiency, low THD distortion (97.5 % with 3.7 % THD) and reduced bill of materials.

It achieves a robust circuit that meets EMC standards up to 4 kV delivering high switching lifetime with reduced EMI emissions.

The thyristor SCR used as AC line polarity switcher allows achieving an active current limitation at power up or line drop recovery: the PFC efficiency is optimal and no EMI bouncing effect occurs.

The reference design includes a power board with bridgeless totem pole boost (with an inrush limiter circuit, switch drivers and an auxiliary power supply), a control board with its MCU, a PFC/ICL control firmware and an adapter board for software debug.

Product summary	
3.6 kW power factor corrector totem pole with inrush current limiter using TN3050H-12WY and SCTW35N65G2V	STEVAL-DPSTPFC1
30 A 1200 V automotive grade SCR thyristor	TN3050H-12WY
galvanically isolated 4 A single gate driver	STGAP2S
silicon carbide power MOSFET	SCTW35N65G2V
Energy saving 12 W high voltage converter with direct feedback	VIPER26LD
Mixed-signal MCU with DSP and FPU for digital power conversion applications	STM32F334
Applications	AC-DC Converters Industrial Power Supply Server and Telecom Power

1 Electrical characteristics

Table 1. Electrical characteristics (T_j=25 °C where not specified)

Symbol	Description	Conditions	Min.	Typ.	Max.	Units
V _{AC}	AC line RMS voltage		85		264	V
I _{AC}	AC line RMS current				16	A
P _{IN}	Input power	V _{AC} = 230 V RMS / 50 Hz			3.6	kW
		V _{AC} = 110 V RMS / 60 Hz			1.6	
f _{AC}	Input AC frequency		45		65	Hz
V _{DC}	Output DC voltage			400	450	V
I _{DC}	Output DC current	V _{AC} = 230 V RMS / 50 Hz			9	A
		V _{AC} = 110 V RMS / 60 Hz			4	
f _s	Switching frequency			72		kHz
η	Peak PFC efficiency	V _{AC} = 230 V RMS / 50 Hz Output power = 2 kW		97.5		%
		V _{AC} = 110 V RMS / 60 Hz Output power = 1 kW		94.8		
T _{AMB}	Ambient temperature		0		45	°C
THD	Min Total Harmonic Distortion	V _{AC} = 230 V RMS / 50 Hz Output power = 2.5 kW		3.3		%
		V _{AC} = 110 V RMS / 60 Hz Output power = 1.4 kW		3.5		
PF	Power factor			0.99		-

Figure 1. STEVAL-DPSTPFC1 power board electrical diagram

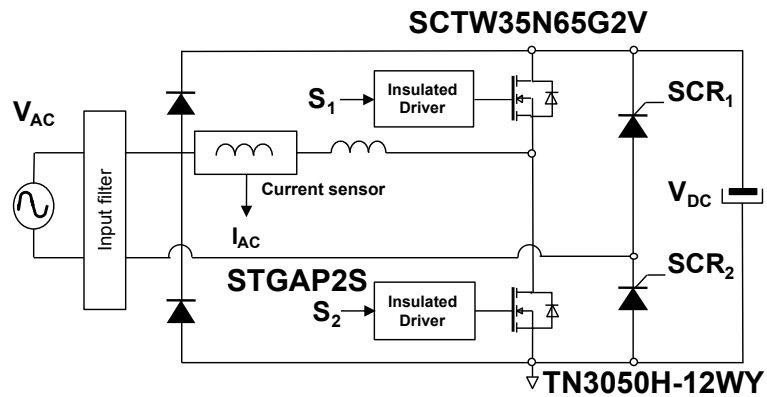
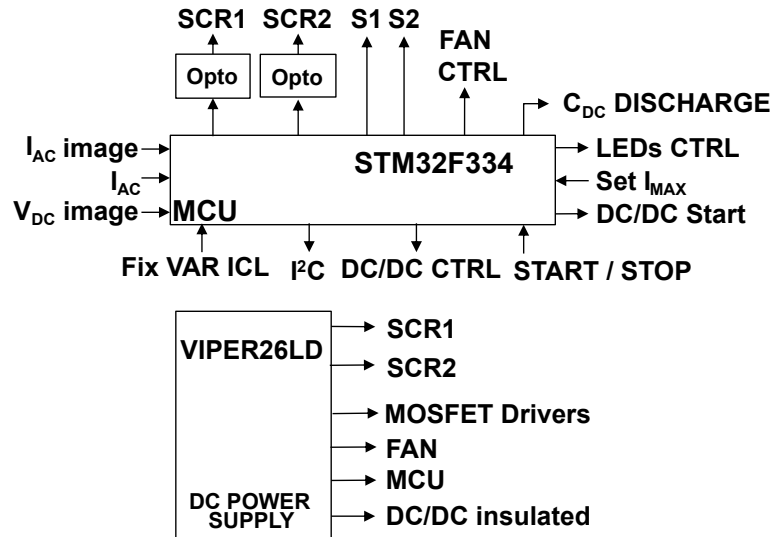

Figure 2. STEVAL-DPSTPFC1 control board electrical diagram and auxiliary power supply



2 Schematic diagrams

Figure 3. STEVAL-DPS334M1 circuit schematic (1 of 3)

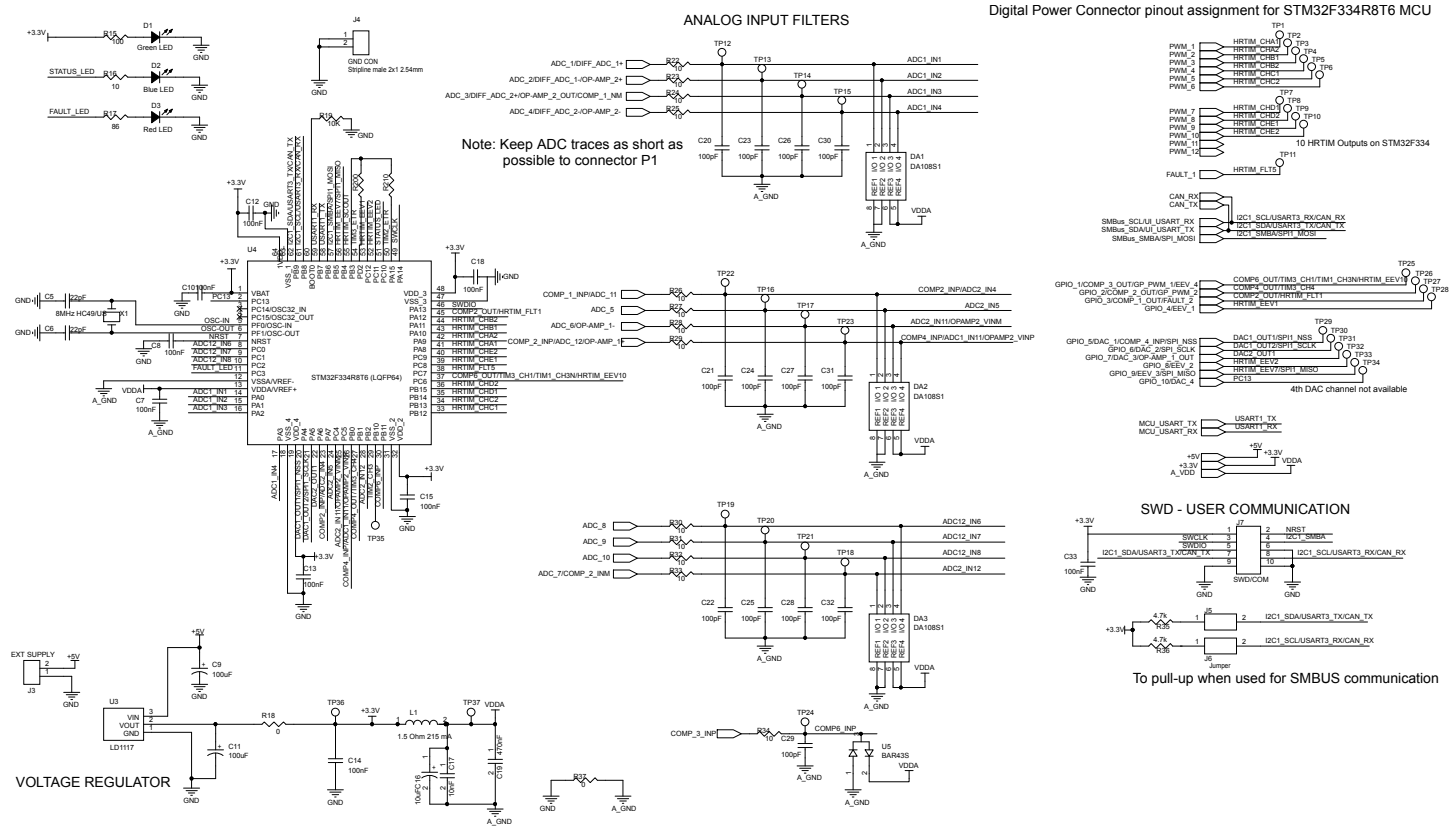

Figure 4. STEVAL-DPS334M1 circuit schematic (2 of 3)

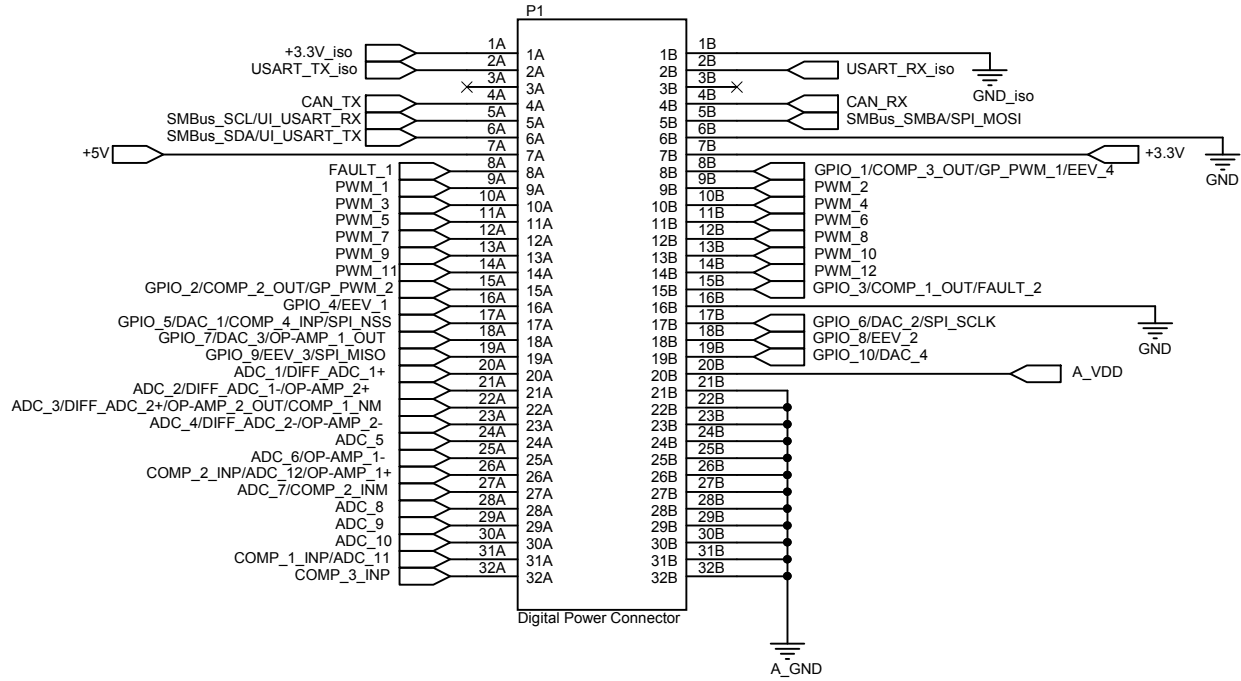

Figure 5. STEVAL-DPS334M1 circuit schematic (3 of 3)

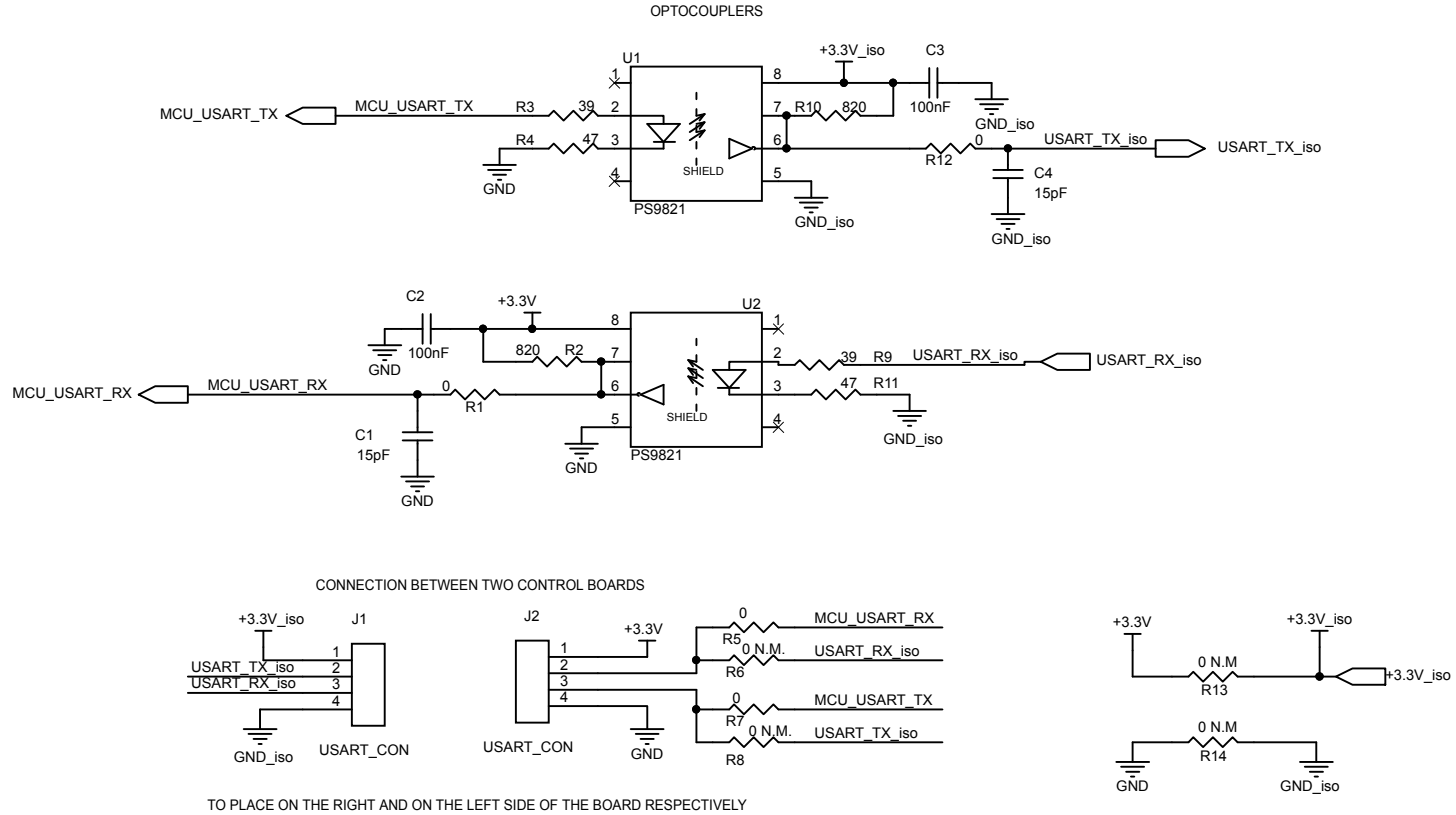

Figure 6. STEVAL-DPSADP01 circuit schematic

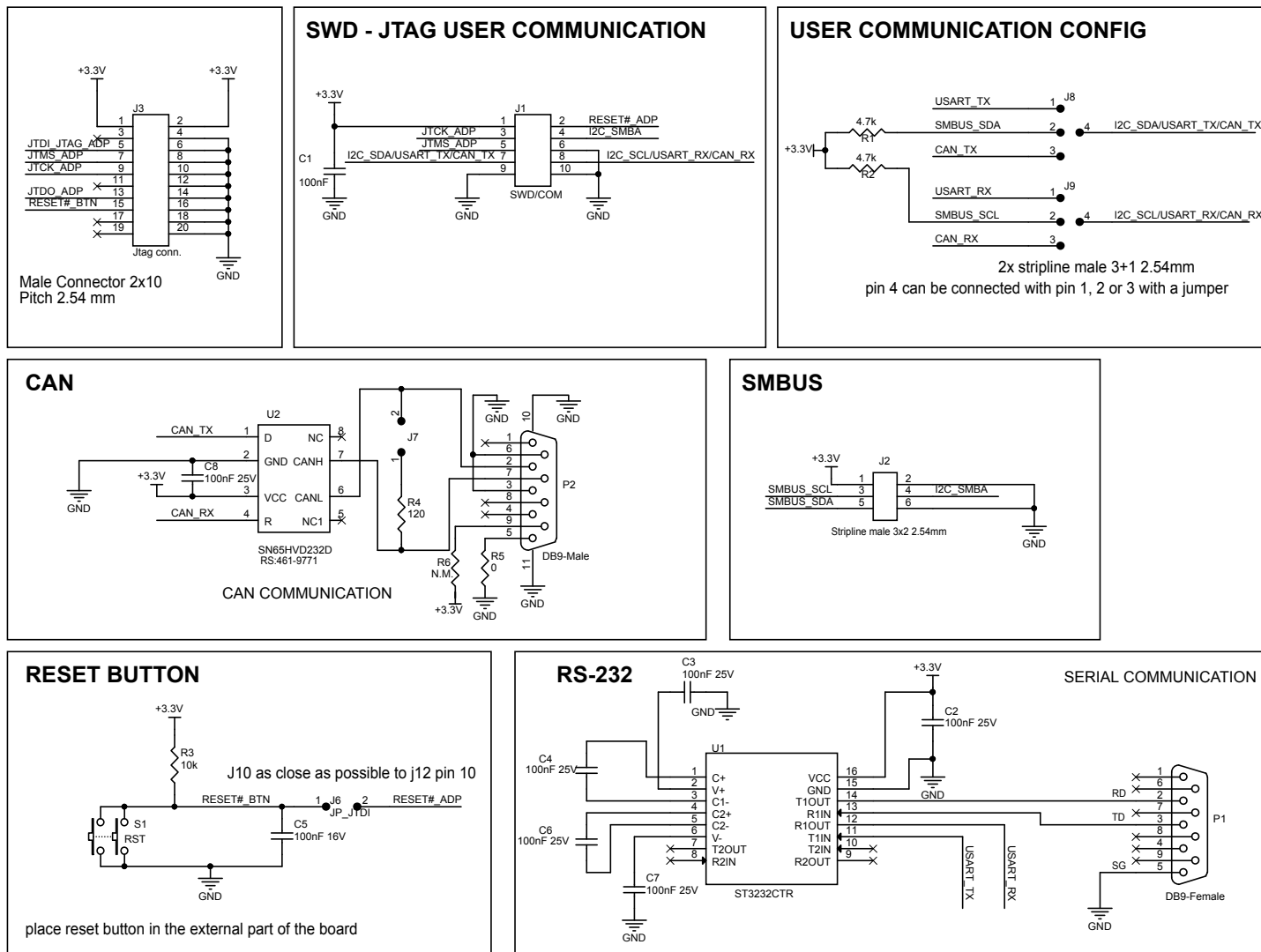
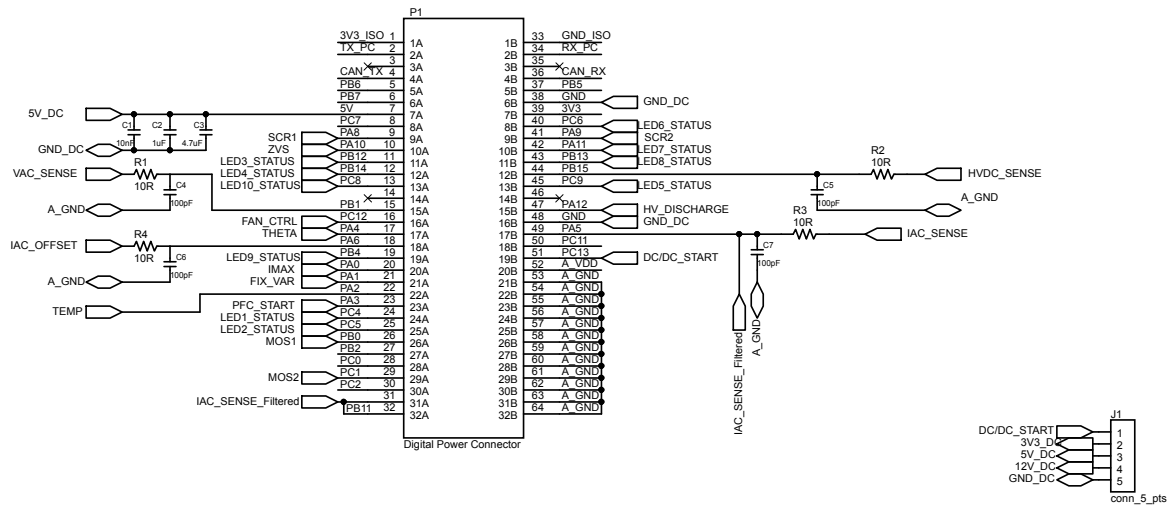

Figure 7. STEVAL-DPSTPFC0 circuit schematic (1 of 4)

EXTERNAL CONNECTORS



LED STATUS

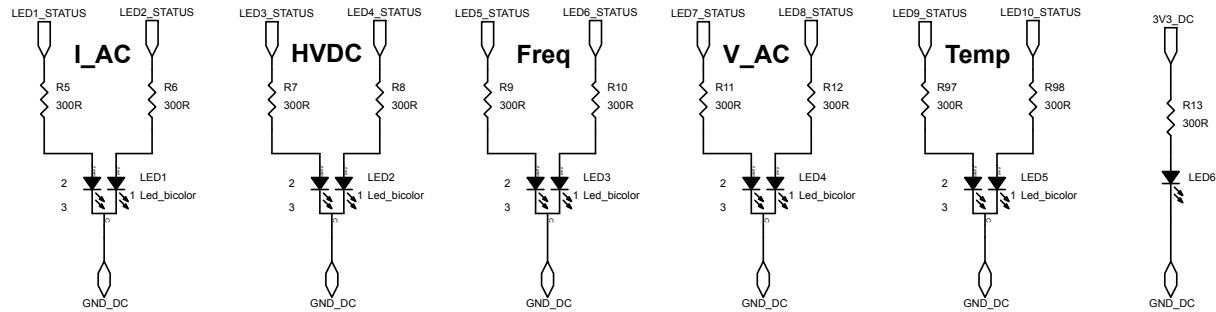

Figure 8. STEVAL-DPSTPFC0 circuit schematic (2 of 4)

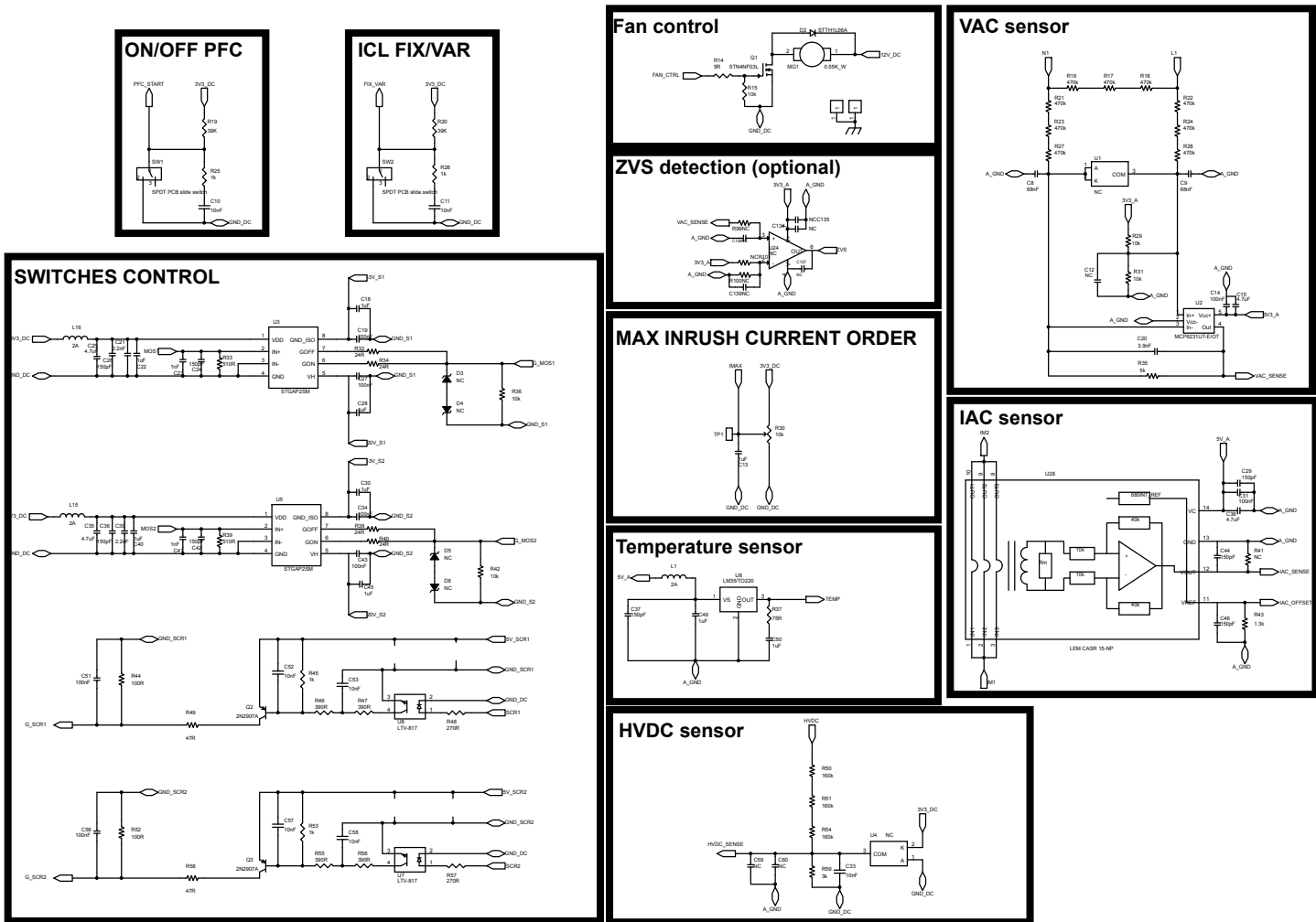

Figure 9. STEVAL-DPSTPFC0 circuit schematic (3 of 4)

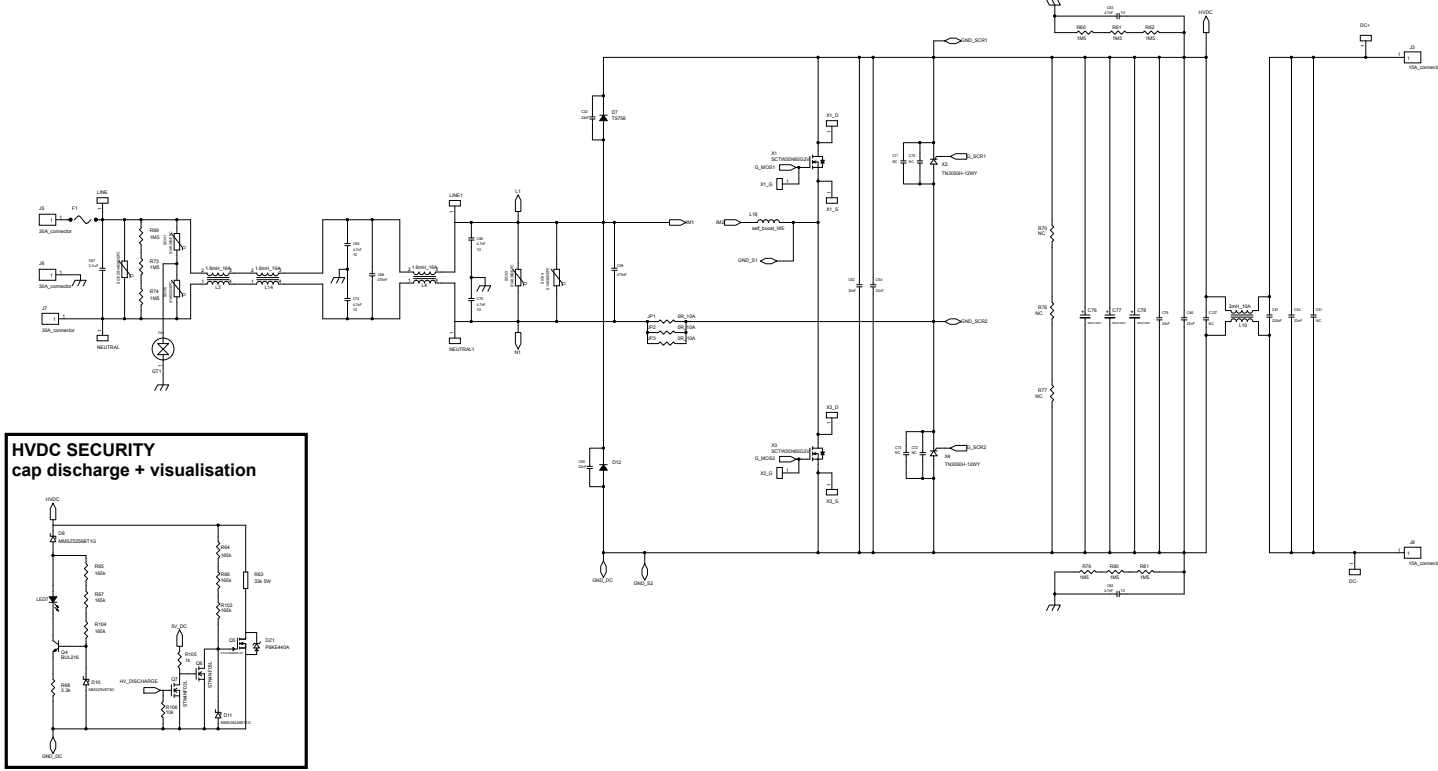
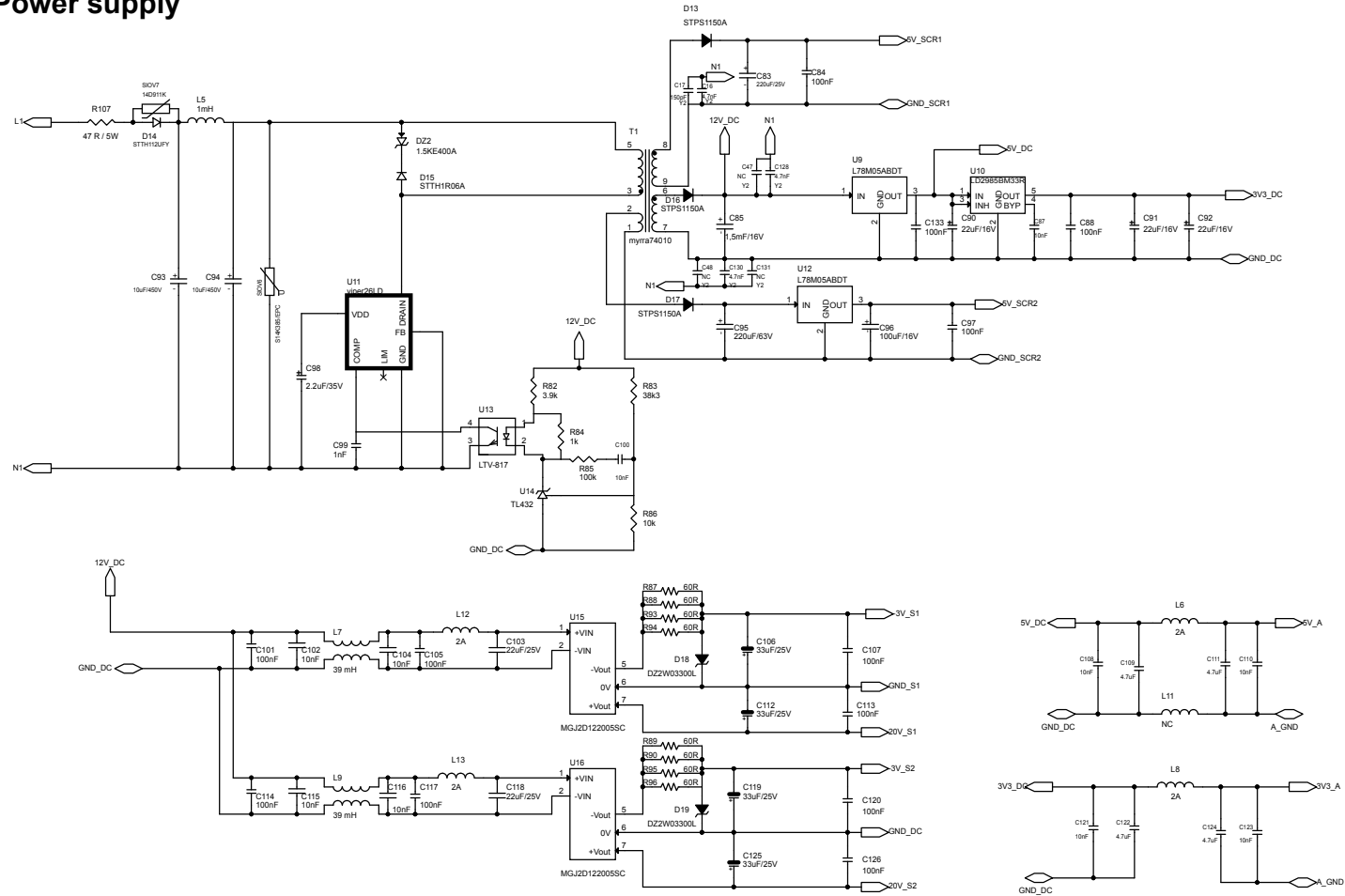

Figure 10. STEVAL-DPSTPFC0 circuit schematic (4 of 4)

Power supply



Revision history

Table 2. Document revision history

Date	Version	Changes
03-May-2019	1	Initial release.
11-Dec-2020	2	Updated cover page image, features, description and product summary table. Updated Section 1 Electrical characteristics . Added Section 2 Schematic diagrams .