

Electronic Speed Controller reference design based on STSPIN32F0A

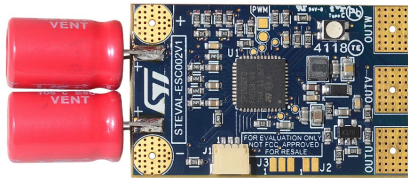

Features

- Very compact and light design
- Designed for sensorless six-step driving
- 2S to 6S LiPo battery pack
- Output current up to 20 A_{RMS}
- Pre-configured firmware package (STSW-ESC002V1)
- BEMF sensing through OpAmps embedded in STSPIN32F0A
- Embedded bootloader through UART interface
- Overcurrent protection
- Battery voltage sensing
- RGB LED
- RoHS compliant
- WEEE compliant
- Compliant with Directive 2006/66/EC

Description

The STEVAL-ESC002V1 board is a very compact and ready to use Electronic Speed Controller (ESC) reference design. The board can easily fit any small and light drone for racing or surveying purposes, and is also highly suitable for any three-phase BLDC application requiring a small form factor, minimal BoM, and high speed rotation performance.

Together with the companion firmware package (STSW-ESC002V1), it represents a solution for sensorless voltage mode six-step driving.

The heart of the board is the STSPIN32F0A advanced 3-phase brushless motor controller that embeds an STM32 Cortex[®]-M0[®] microcontroller, voltage regulators, signal conditioning circuitry and gate drivers in a small 7x7 mm² QFN package. The power stage is based on the 2.8 mΩ low resistance, high speed STL140N6F7 MOSFETs, designed with STripFET™ F7 technology and able to deliver up to 20 A of continuous current.

Product summary	
Electronic Speed Controller reference design based on STSPIN32F0A	STEVAL-ESC002V1
Six-step reference design firmware for STEVAL-ESC002V1	STSW-ESC002V1
N-channel 60 V, 0.0024 Ohm typ., 140 A STripFET F7 Power MOSFET in a PowerFLAT 5x6 package	STL140N6F7
Advanced BLDC controller with embedded STM32 MCU	STSPIN32F0A

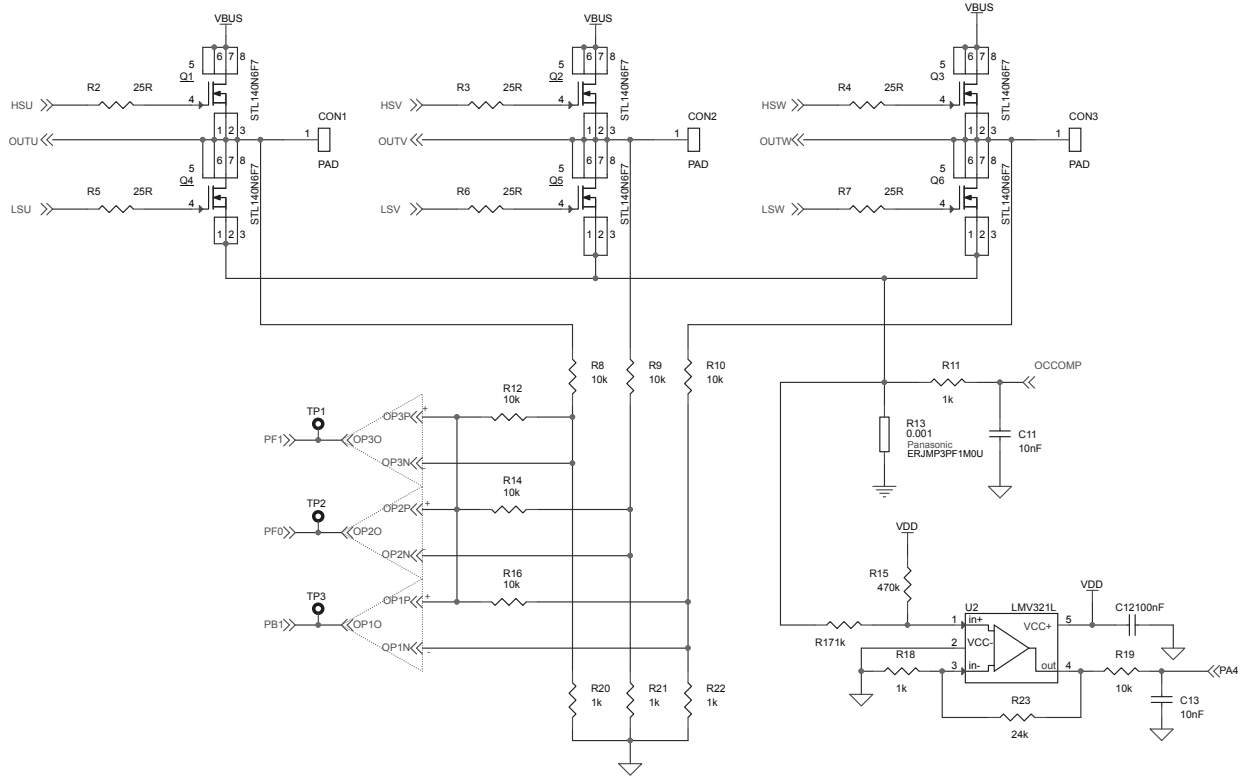
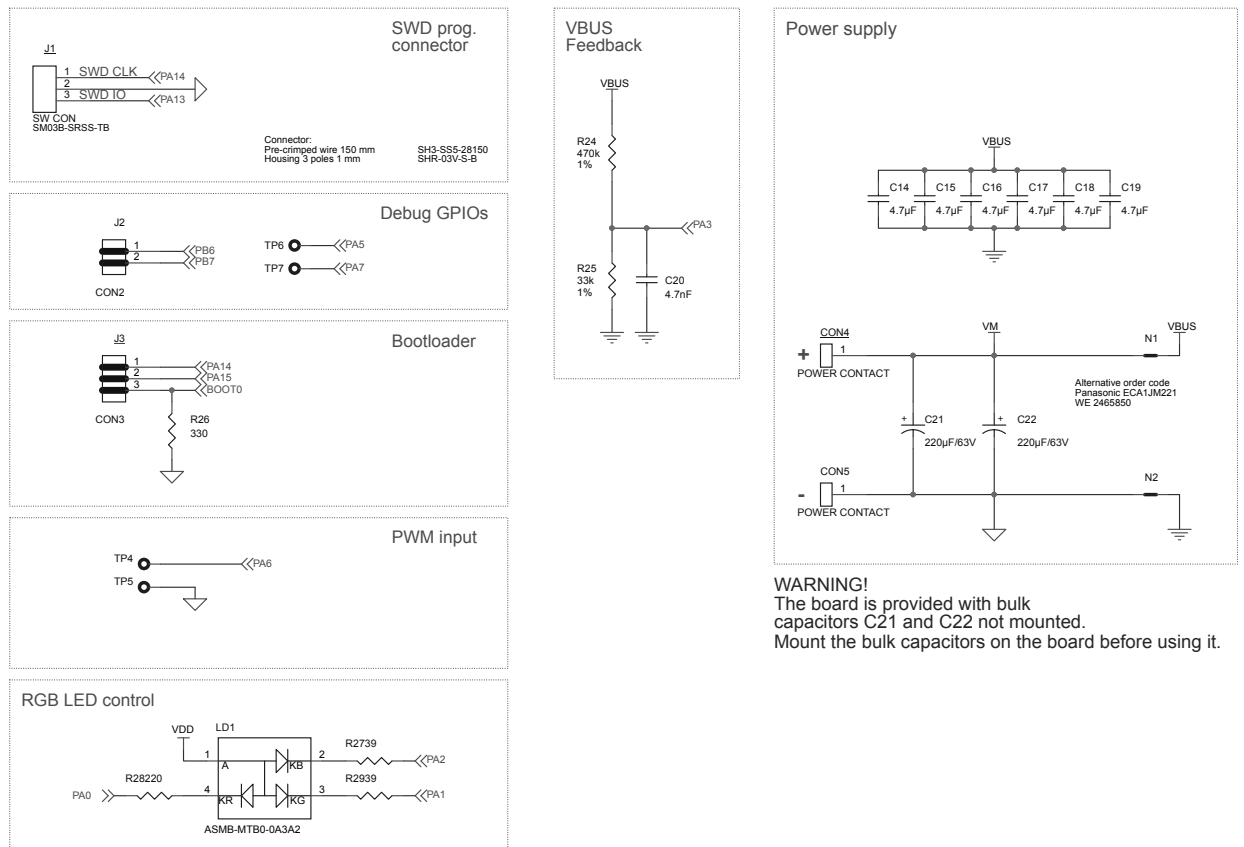
Figure 2. STEVAL-ESC002V1 board schematic (2 of 3)

Figure 3. STEVAL-ESC002V1 board schematic (3 of 3)

WARNING!
The board is provided with bulk capacitors C21 and C22 not mounted. Mount the bulk capacitors on the board before using it.

Revision history

Table 1. Document revision history

Date	Version	Changes
04-Dec-2018	1	Initial release.