

## Flight controller unit evaluation board for toy drones

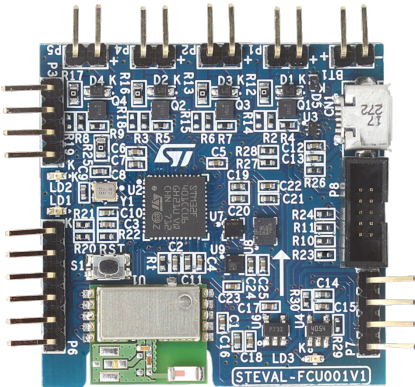

### Features

- Compact flight controller unit (FCU) evaluation board complete with sample firmware for a small or medium sized quadcopter
- On-board LiPo 1-cell battery charger
- Possibility to directly drive 4 DC brushed motors through the low voltage on-board MOSFET or alternatively use external ESC for DC brushless motor configuration
- Main components:
  - [STM32F401](#) – 32-bit MCU with ARM® Cortex®
  - [LSM6DSL](#) – iNEMO inertial module: 3D accelerometer and 3D gyroscope
  - [LIS2MDL](#) – High performance 3D magnetometer
  - [LPS22HD](#) – MEMS pressure sensor: 260-1260 hPa absolute digital output barometer
  - [SPBTLE-RF](#) – Very low power module for Bluetooth Smart v4.1
  - [STL6N3LLH6](#) - N-channel 30 V, 6 A STripFET H6 Power MOSFET
  - [STC4054](#) - 800 mA standalone linear Li-Ion battery charger
- RoHS compliant
- WEEE compliant

### Description

The [STEVAL-FCU001V1](#) is designed to support quadcopter drone designers.

A complete sample firmware project allows the designer to begin flying small or medium sized quadcopters (with brushed or brushless DC motors) immediately and evaluate the performance of the IMU sensors under real flight conditions.

The FCU can be controlled by a standard external remote controller (PWM input interface) or by a smartphone or tablet through the on-board Bluetooth low energy module (CE, FCC, ARIB, BQE certified).

Magnetometer and pressure sensors are also embedded to support 3D navigation applications.

SWD, I<sup>2</sup>C and USART connectors are available for firmware development and debugging, and to support additional external sensors or RF modules.

Product summary	
Flight controller unit evaluation board for toy drones	<a href="#">STEVAL-FCU001V1</a>
iNEMO 6DoF inertial measurement unit	<a href="#">LSM6DSL</a>
Magnetic sensor, digital output, 3-axis magnetometer	<a href="#">LIS2MDL</a>
Piezoresistive absolute pressure sensor digital output barometer	<a href="#">LPS22HD</a>
Very low power module for Bluetooth Smart v4.1	<a href="#">SPBTLE-RF</a>
N-channel, STripFET H6 Power MOSFET	<a href="#">STL6N3LLH6</a>
800 mA standalone linear Li-Ion battery charger	<a href="#">STC4054</a>
Drone remote controller app for Android	<a href="#">AppDrone</a>
Reference design firmware for mini drones	<a href="#">STSW-FCU001</a>

# 1 Schematic diagrams

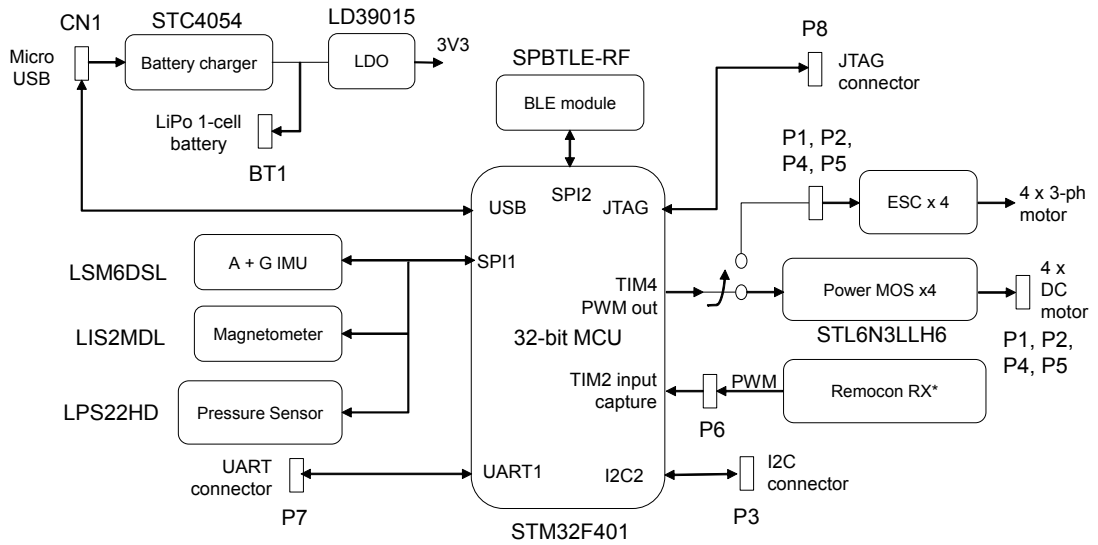
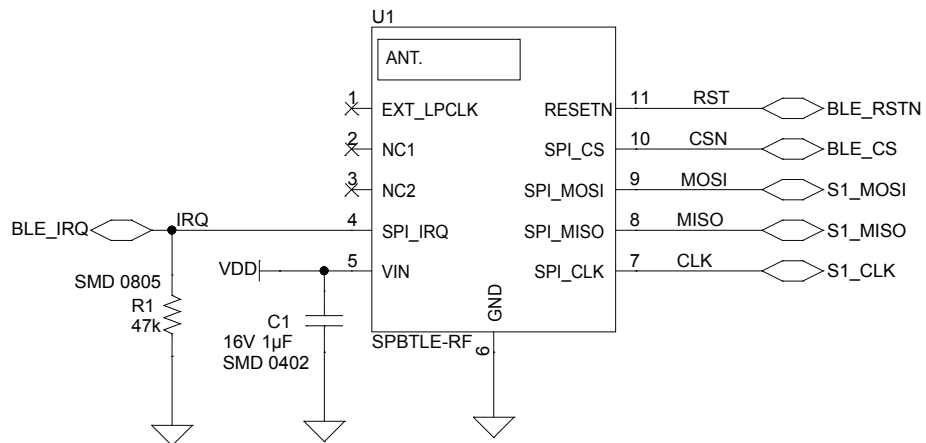
**Figure 1. STEVAL-FCU001V1 – block diagram**

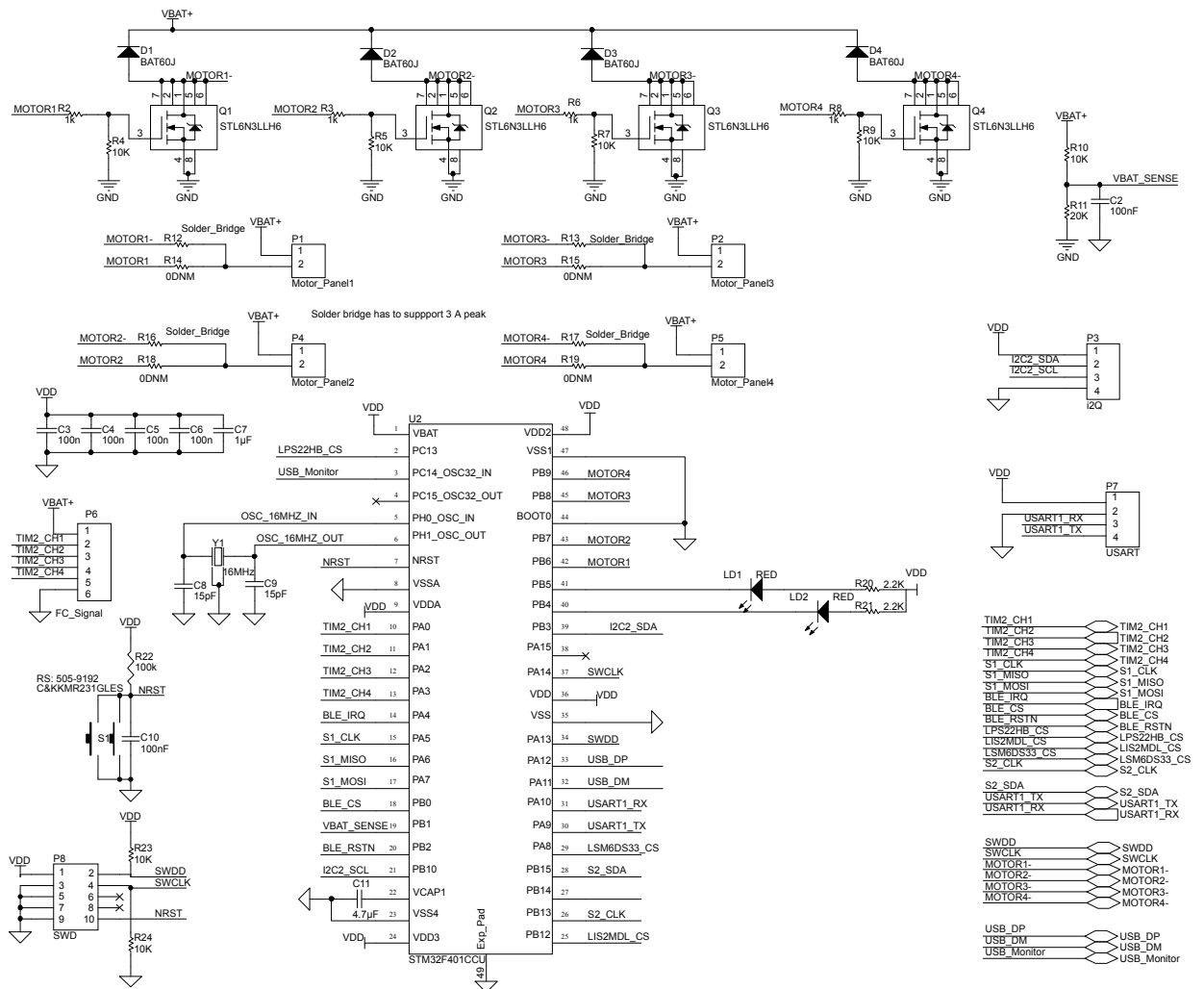
**Figure 2. STEVAL-FCU001V1 – circuit schematic (1 of 4)**
**SPBTLE-RF**

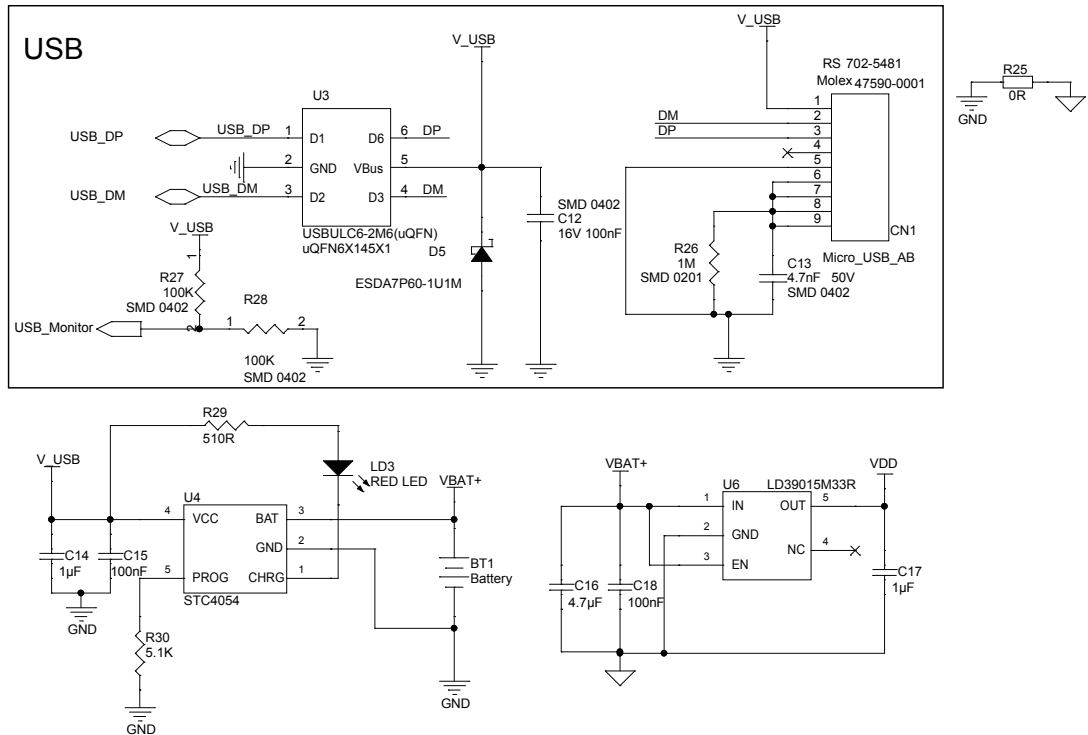
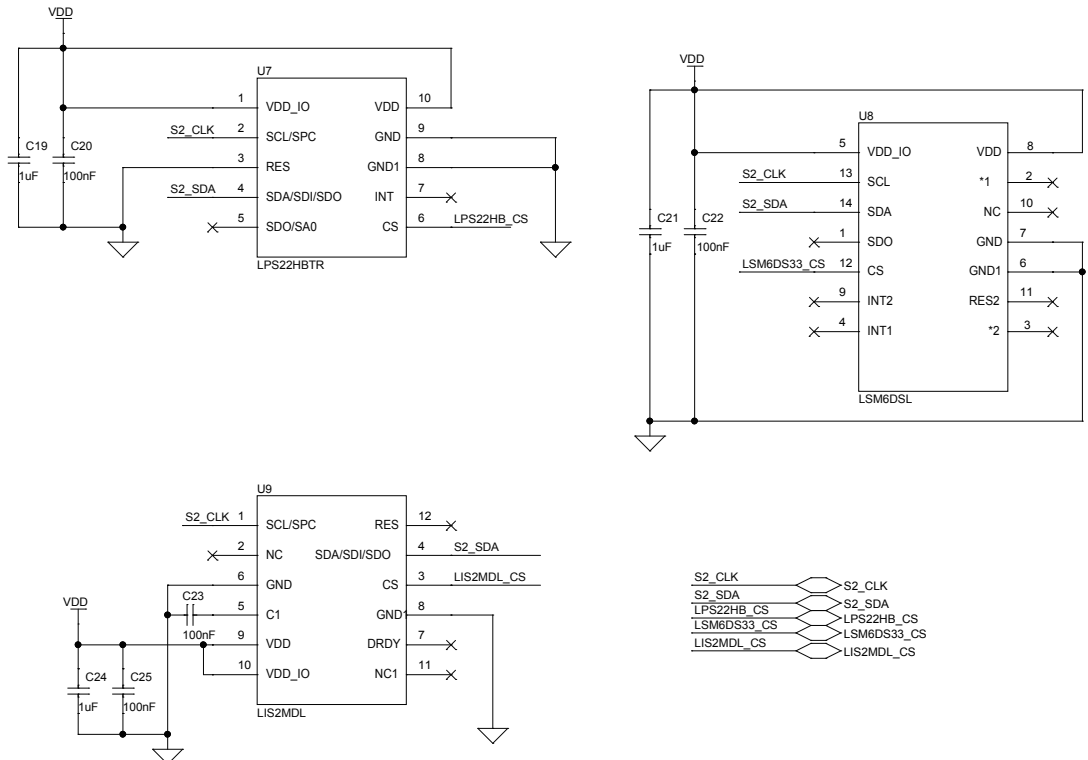
**Figure 3. STEVAL-FCU001V1 – circuit schematic (2 of 4)**

**Figure 4. STEVAL-FCU001V1 – circuit schematic (3 of 4)**

**Figure 5. STEVAL-FCU001V1 – circuit schematic (4 of 4)**

## Revision history

**Table 1. Document revision history**

Date	Version	Changes
03-Oct-2017	1	Initial release.
16-Jan-2019	2	Updated cover page image.