

Dual radio BLE and Sub-1GHz development kit for Sigfox™ and LPWAN protocols with BlueNRG-1 and S2-LP

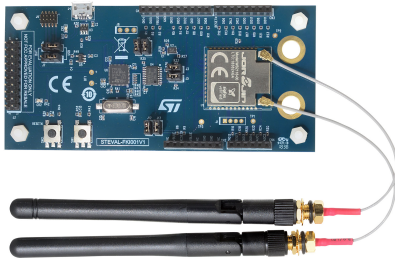

Features

- WS2118-00 Sigfox™ BLE module (Jorjin):
 - Embedded BlueNRG-132 Bluetooth low energy SOC based on ultra-low power Arm® Cortex®-M0 (up to +8 dBm BLE RF output power, excellent receiver sensitivity -88 dBm)
 - Embedded S2-LPQTR ultra-low power sub-1 GHz transceiver tuned for 826-958 MHz frequency bands (up to +16 dBm sub-1GHz RF output power, excellent receiver sensitivity down to -130 dBm, modulation schemes: 2-(G)FSK, 4-(G)FSK, OOK, and ASK, air data rate from 0.1 to 500 kbps, ultra-low power consumption: (7 mA RX, 10 mA TX @ +10 dBm), low duty cycle RX/TX operation mode, automatic acknowledgement, retransmission, and timeout protocol engine)
 - BALF-NRG-01D3 50 Ω integrated balun, matching network and harmonics filter companion device of BlueNRG-1
 - Low power and wide supply voltage range: 2.0 to 3.6 V
 - Dimensions: 22 mm(l) x 24 mm(w) x 2.8 mm(h)
 - Operating temperature range: -40 °C to +85 °C
 - U.FL RF interface connectors
- USB interface
- Arduino™ Uno V3 connectors
- JTAG debug connectors
- Antennas: 2.4 GHz and Sub-1 GHz
- USB cable
- RoHS compliant and China RoHS compliant
- CE compliant
- WEEE compliant

Description

The **STEVAL-FKI001V1** development kit is a cost-effective tool to help you design solutions based on Sigfox™, Bluetooth® low energy and sub-1GHz technologies.

The kit features a fully programmable module WS2118 (by Jorjin), which embeds the **BlueNRG-1** system-on-chip for Bluetooth® low energy functionality and the **S2-LP** transceiver for sub-1GHz functionality such as LPWAN protocols.

This development effectively combines Bluetooth low energy features with the connection capacity of Sigfox wide-area networks.

It includes examples and recommendations regarding the simultaneous use of the two protocols. Very low active RF and MCU current, and low-power mode current consumption provide excellent battery lifetime, allowing operation with coin cell batteries and energy-harvesting applications.

The STEVAL-FKI001V1 evaluation board uses the Arduino interface to help development, as it is compatible with ST Arduino shield boards featuring MEMS motion sensors, environmental sensors, and Time-of-Flight (ToF) ranging sensors.

Summary table	
Dual radio BLE and Sub-1GHz development kit for Sigfox™ and LPWAN protocols with BlueNRG-1 and S2-LP	STEVAL-FKI001V1
ultra-low power, high performance, sub-1GHz transceiver	S2-LP
Bluetooth low energy wireless system-on-chip	BlueNRG-1

1 Schematic diagram

Figure 1. STEVAL-FKI001V1 board schematic (1 of 2)

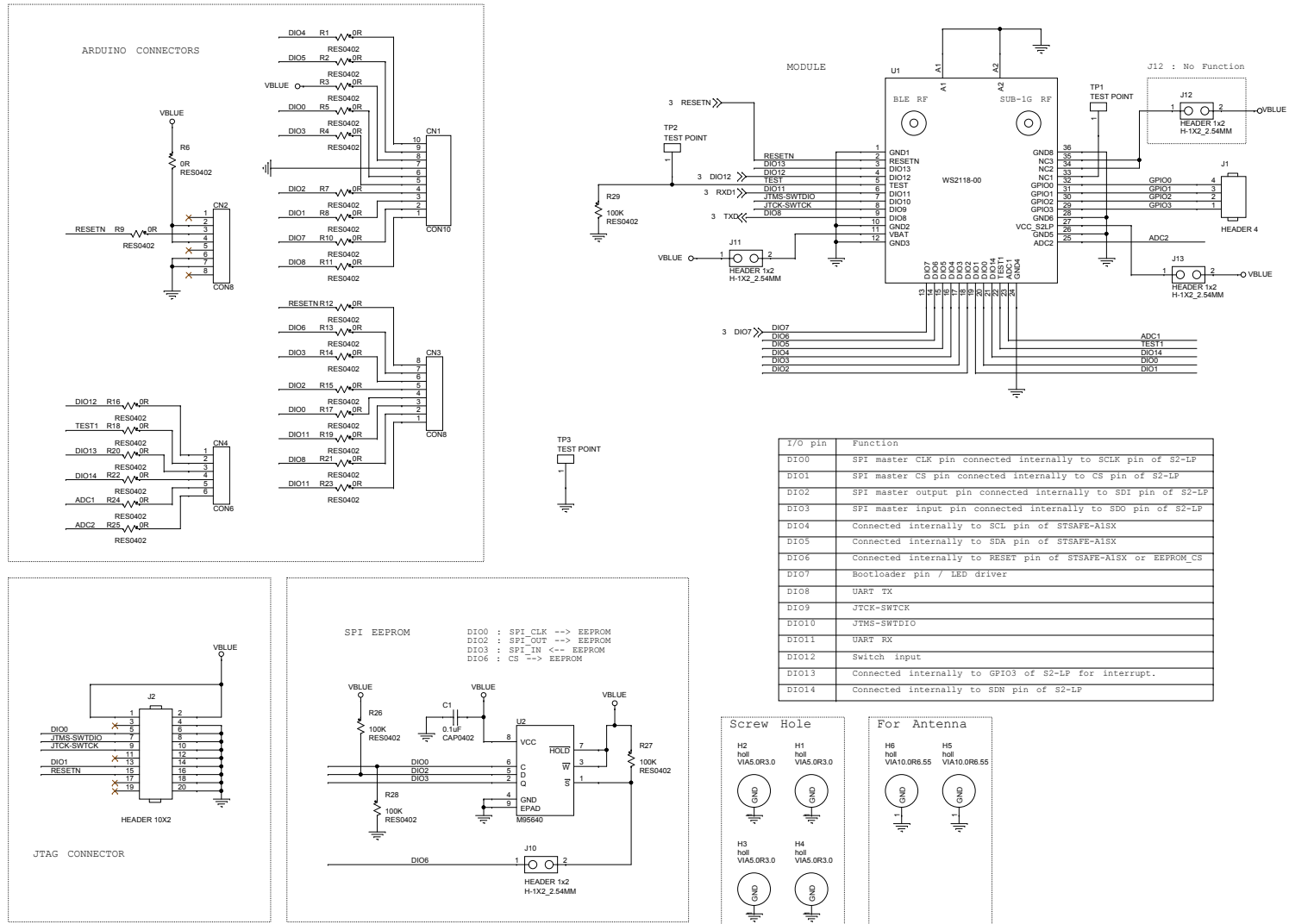
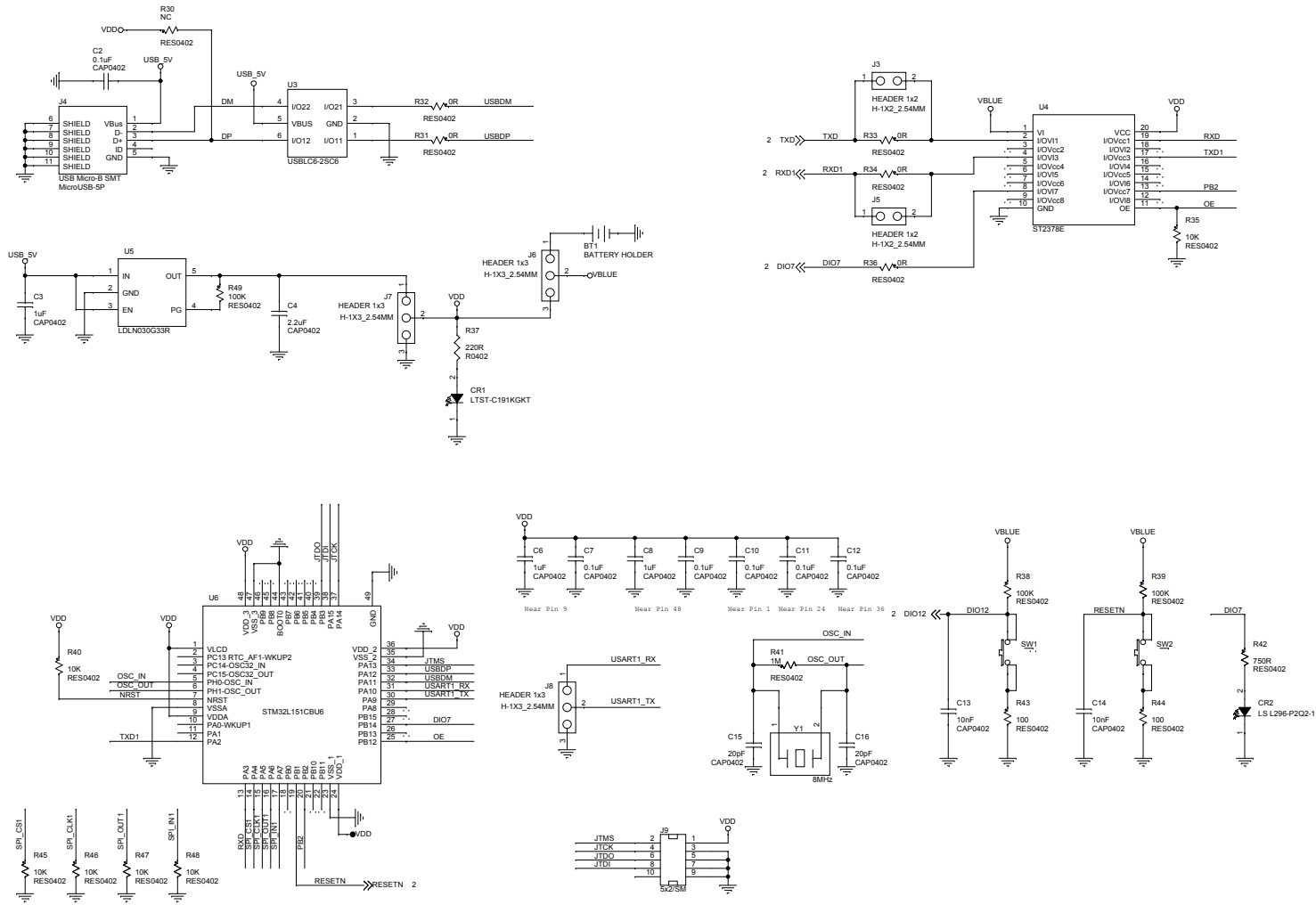

Figure 2. STEVAL-FKI001V1 board schematic (2 of 2)



Revision history

Table 1. Document revision history

Date	Version	Changes
18-Oct-2018	1	Initial release.
11-Dec-2018	2	Update Section 1 Schematic diagrams and cover image