

Sub-1GHz (860-940 MHz) transceiver development kit based on S2-LP

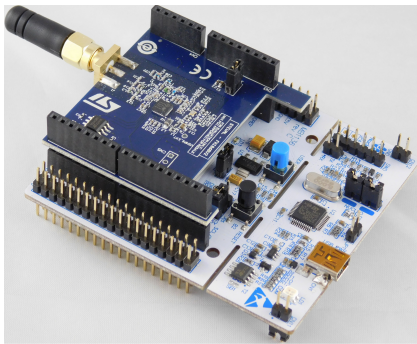

Features

- S2-LP narrow band ultra-low power sub-1GHz transceiver in a standalone RF Module tuned for 860-940 MHz frequency bands
- STM32 Nucleo-64 development board with STM32L0 MCU
- Suitable for Wireless M-Bus systems
- Associated S2-LP development kit including, documentation, firmware for STM32L and GUI
- Programmable RF output power up to +16 dBm
- Modulation schemes: 2-FSK, 2-GFSK, 4-FSK, 4-GFSK, OOK, and ASK
- Air data rate from 0.3 to 500 kbps
- Ultra-low power consumption:
 - 6.7 mA RX
 - 10 mA TX @ +10 dBm
- Excellent performance of receiver sensitivity (up to -130 dBm)
- Low duty cycle RX/TX operation mode
- Automatic acknowledgement, retransmission, and timeout protocol engine
- SPI interface for microcontroller
- USB interface
- RoHS compliant

Description

The STEVAL-FKI868V2 evaluation board is based on the [S2-LP](#) sub-1GHz ultra-low power low data-rate transceiver suitable for ISM bands and wireless M-Bus. The [NUCLEO-L053R8](#) motherboard is equipped with an STM32L0 low power microcontroller to control the S2-LP.

The board integrates a ST-LINK/V2-1 debugger/programmer for firmware updating.

Summary table	
STEVAL-FKI868V2 evaluation board	STEVAL-FKI868V2
STM32 Nucleo-64 development board with STM32L053R8 MCU	NUCLEO-L053R8
ultra-low power, high performance, sub-1GHz transceiver	S2-LP
STM32L0 series of ultra-low-power MCUs	STM32L0
ST-LINK/V2 in-circuit debugger/programmer for STM8 and STM32	ST-LINK/V2

1 Schematic diagram

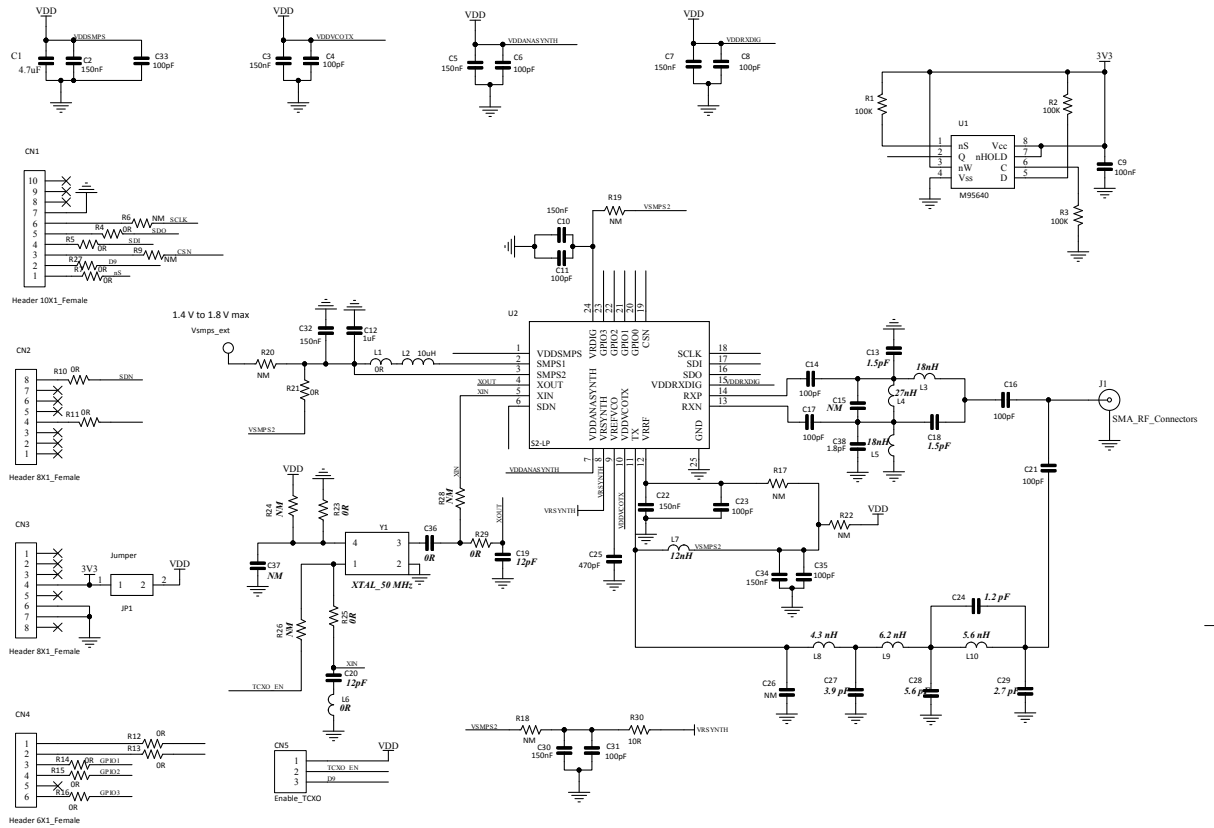
Figure 1. STEVAL-FKI868V2 circuit schematic

Revision history

Table 1. Document revision history

Date	Version	Changes
01-Mar-2018	1	Initial release.
23-Mar-2018	2	Updated title.
05-Jun-2018	3	Updated Figure 1. STEVAL-FKI868V2 circuit schematic