

## Reference design kit for Gimbal controller for drones and handheld applications

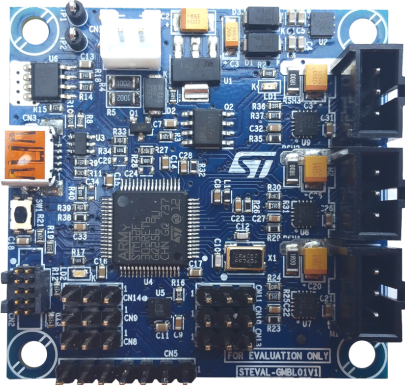

### Features

- Up to three-axis Gimbal controller.
- Compact (50 x 50 mm) design, suitable for mounting on:
  - drones
  - handheld cameras
- Three [STSPIN233](#) low voltage three phase and three sense motor drivers.
- [STM32F303RE](#) microcontroller with ARM® Cortex®-M4 core able to simultaneously drive three PMSM motors:
  - MCU runs a high efficiency field oriented control (FOC) algorithm compatible with the most common position sensors on Gimbal motors (PWM or analogic inputs)
  - compatible with open loop sensorless algorithm
- Operating voltage from 6.0 V to 8.4 V (2 LiPo batteries).
  - maximum output current 1.3 A<sub>RMS</sub>.
- Protection mechanisms:
  - triple single shunt current sensing network
  - non-dissipative overcurrent protection
  - short-circuit protection
  - thermal shutdown
  - hardware overvoltage and polarity inversion protection
- Measurement units:
  - on-board inertial measurement unit [LSM6DSL](#) (frame IMU)
  - compatible with external SPI/I2C inertial measurement units (camera IMU)
- Interfaces:
  - STEVAL-UKI001V1 Serial Wire Debug (SWD) board with cable
  - USB connector for real-time data communication
  - three connectors for Pitch, Roll and Tilt axis target angle inputs (PWM mode)
  - one channel DAC output and one GPIO test point for debugging purpose
- 2 Kbit serial I<sup>2</sup>C bus EEPROM for data storage
- WEEE and RoHS compliant

Product summary	
Reference design kit for Gimbal controller	<a href="#">STEVAL-GMBL02V1</a>
Mixed signal MCU ARM Cortex-M4 core with DSP and FPU	<a href="#">STM32F303RE</a>
Low voltage three phase and three sense motor driver	<a href="#">STSPIN233</a>

### Description

The [STEVAL-GMBL02V1](#) reference design kit is a complete triple motor field-oriented control (FOC) demonstration and evaluation platform as well as an integrated environment for three axis Gimbal controller applications in the 6.0 V to 8.4 V<sub>DC</sub> bus voltage range (2 LiPo batteries), which you can increase up to 11 V with a maximum output current of 1.3 A for each motor drive.

The design features the [STM32F303RE](#) microcontroller with ARM® Cortex®-M4 32-bit core and the [STSPIN233](#) low voltage three phase and three sense motor driver.

The kit is equipped with a USB interface for real-time data exchange and includes an STEVAL-UKI001V1 ST-LINK adapter for serial wire debug (SWD) and corresponding cable. If you mount the STEVAL-UKI001V1 on the ST-LINK/V2-1 debugging section of an [STM32 Nucleo-64](#) board, you can program and debug the [STM32F303RE](#) microcontroller with a compatible toolset via USB.

## 1.1 STEVAL-GMBL01V1 controller board schematic diagrams

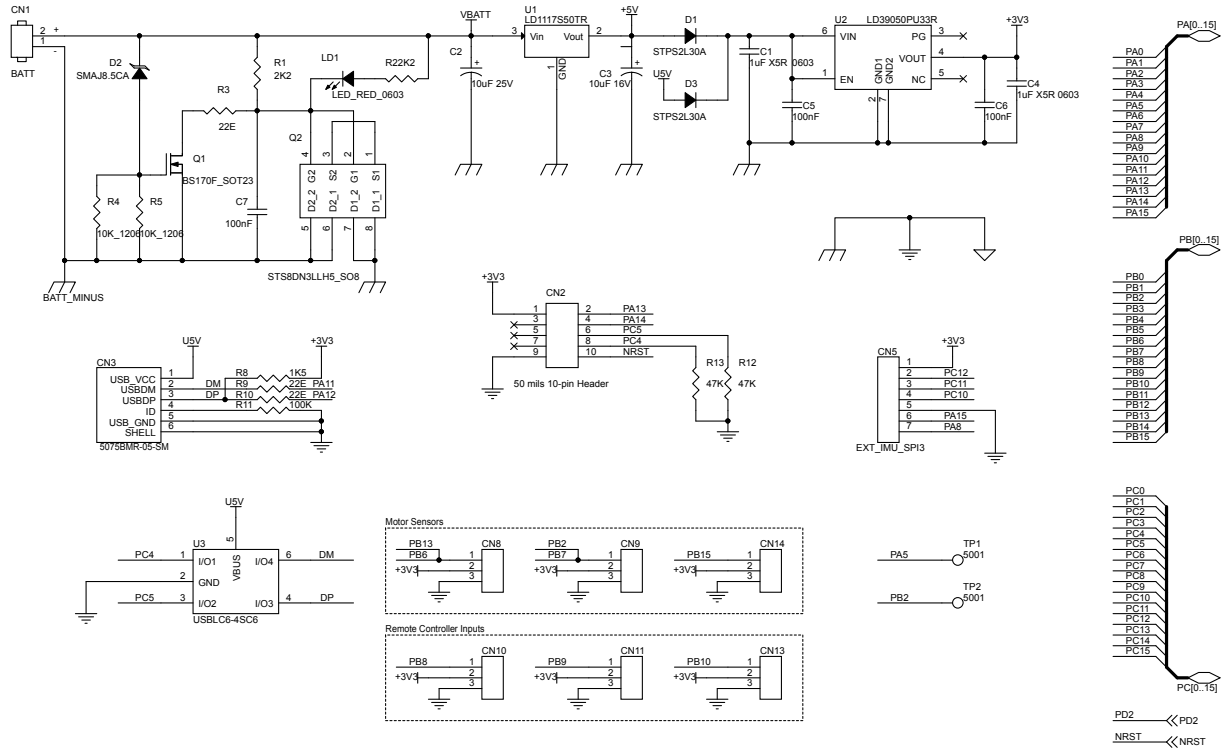
**Figure 1. STEVAL-GMBL01V1 schematic - interfaces**

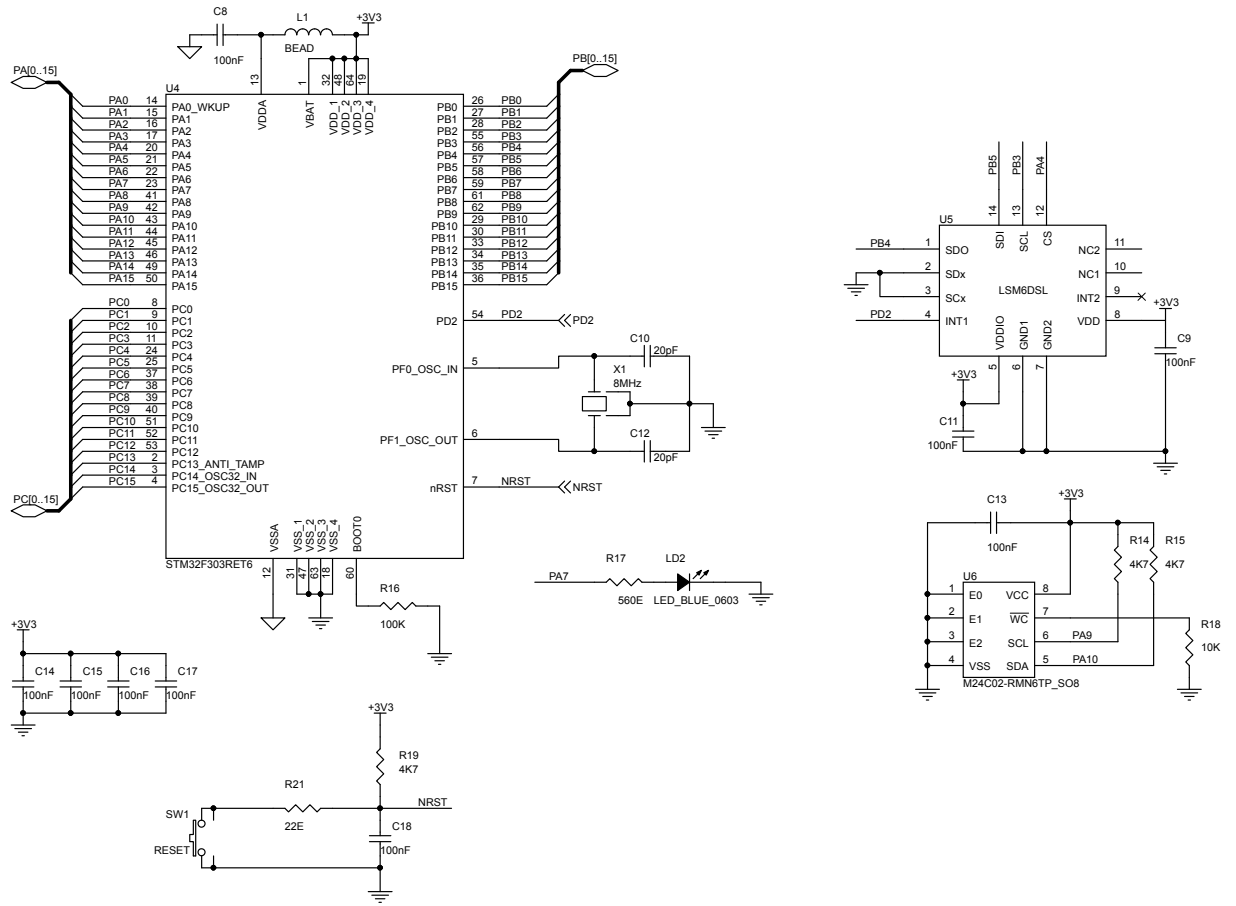
**Figure 2. STEVAL-GMBL01V1 schematic – MCU, IMU sensor, EEPROM**

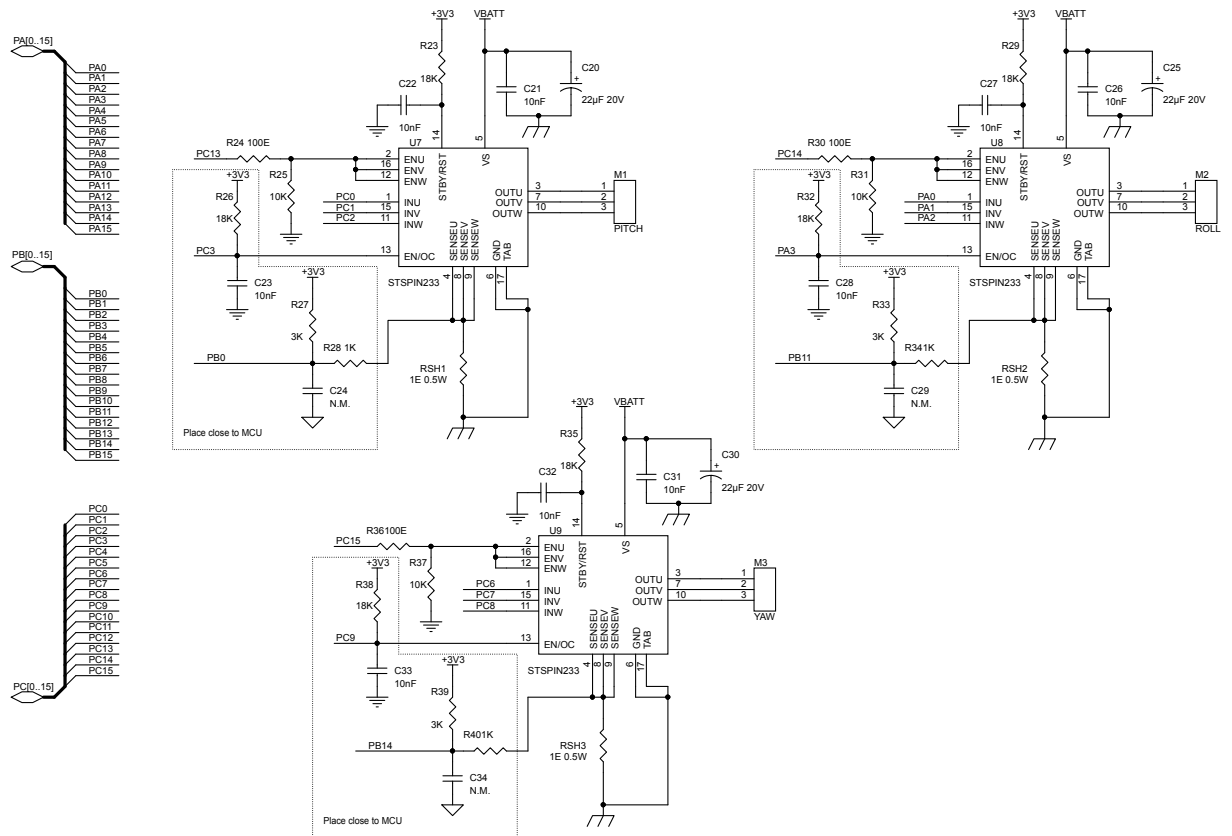
**Figure 3. STEVAL-GMBL01V1 schematic – motor control**

## 1.2 STEVAL-UKI001V1 adapter board schematic diagram

Figure 4. STEVAL-UKI001V1 schematic

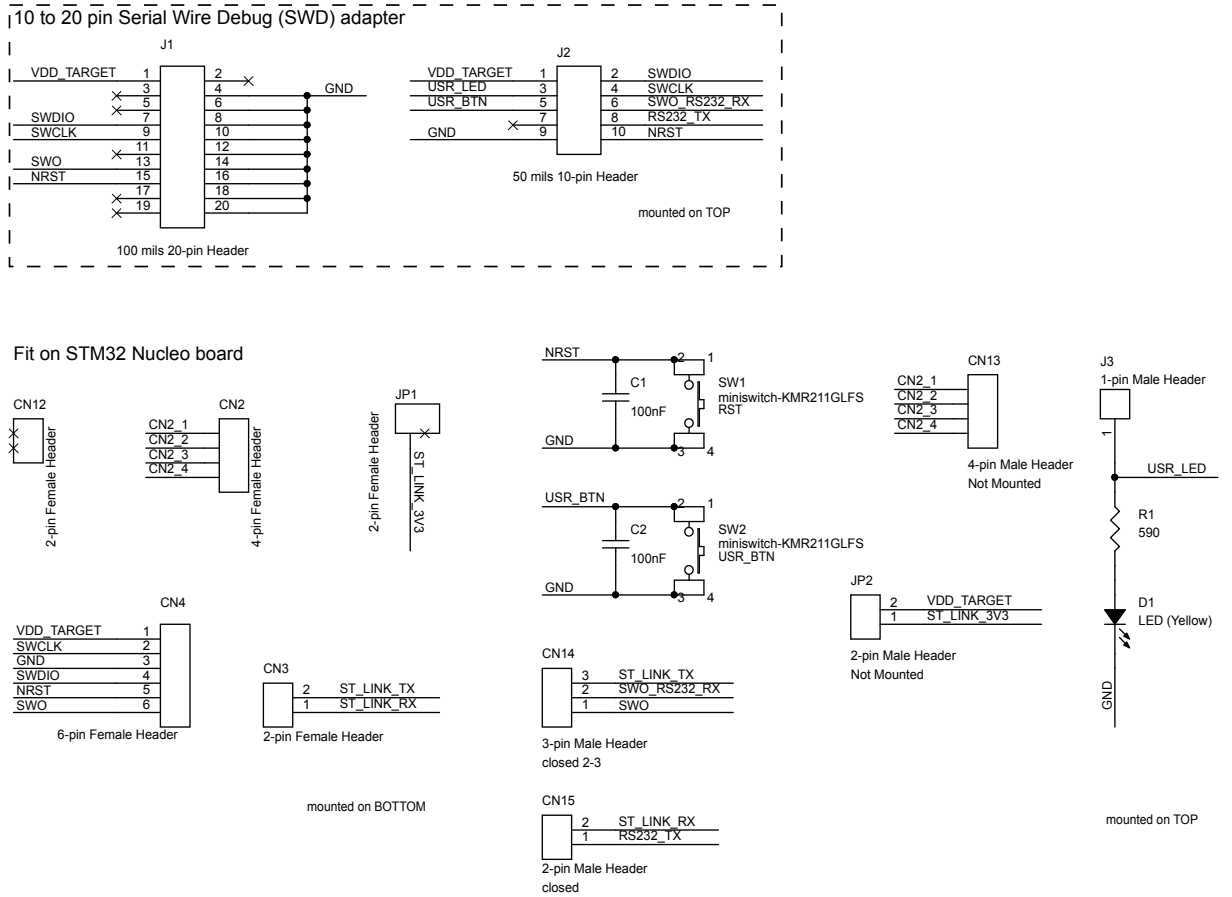

## Revision history

**Table 1. Document revision history**

Date	Version	Changes
20-Aug-2018	1	Initial release.
18-Oct-2018	2	Updated cover image.