

IO-Link industrial modular sensor board based on L6362A

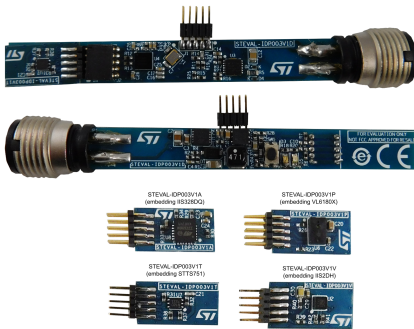

Features

- Main supply voltage: 32 V maximum
- STM32L071CZ microcontroller
- IO-Link PHY using the [L6362A](#) device for data communication with host unit
- DC-DC converter and linear regulator on board
- Integrated reverse polarity protection on [L6362A](#) ICs
- Multi-sensor connection
- 400 kHz I²C communication
- PCB designed to accept real industrial sensors (8 mm x 70 mm, with 0.8 mm thickness)
- Designed to meet IEC industrial standard requirements
- RoHS compliant

Description

The [STEVAL-IDP003V1](#) kit includes the [STEVAL-IDP003V1D](#) evaluation board based on the [L6362A](#) IO-Link device transceiver and the [STM32L071CZ](#) microcontroller for data processing, as well as the following sensor daughter boards: [STEVAL-IDP003V1T](#) hosting the [STTS751](#) temperature sensor, [STEVAL-IDP003V1V](#) hosting the [IIS2DH](#) MEMS sensor, [STEVAL-IDP003V1A](#) hosting the [IIS328DQ](#) MEMS sensor and [STEVAL-IDP003V1P](#) hosting the [VL6180X](#) proximity sensor.

The evaluation kit is equipped with an industrial M12 connector (required by the standard) for connection with a single master IC using a 20-meter cable. The wire is a normal three-pole wire: one for IO-Link data, one for the L+ line (positive supply voltage pole) and one for the L- line (negative supply voltage pole).

The layout is designed to meet IEC61000-4-2/4 and EN60947 requirements for the industrial sector.

Product summary	
IO-Link industrial modular sensor board based on L6362A	STEVAL-IDP003V1
IO-Link communication transceiver device IC	L6362A
Ultra-low-power Arm Cortex-M0+ MCU	STM32L071CZ
Applications	Condition Monitoring/ Predictive Maintenance Factory Automation IO-Link

1 Block identification

In the kit, the main board is the STEVAL-IDP003V1.

Figure 1. STEVAL-IDP003V1 block identification

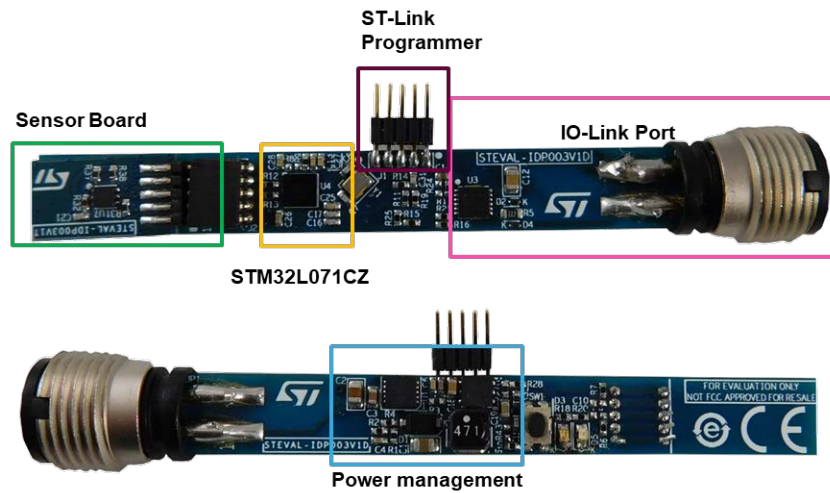

The picture below shows the sensor daughter boards, from the top left corner in a clockwise direction: STEVAL-IDP003V1T, STEVAL-IDP003V1P, STEVAL-IDP003V1A and STEVAL-IDP003V1V. The corresponding sensor part numbers are also shown.

Figure 2. Sensor boards

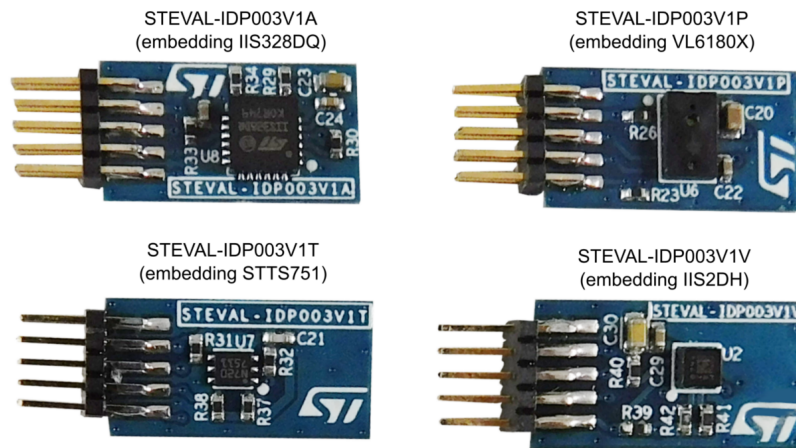

2 Schematic diagrams

Figure 3. STEVAL-IDP003V1 circuit schematic (1 of 6) - step-down switching regulator

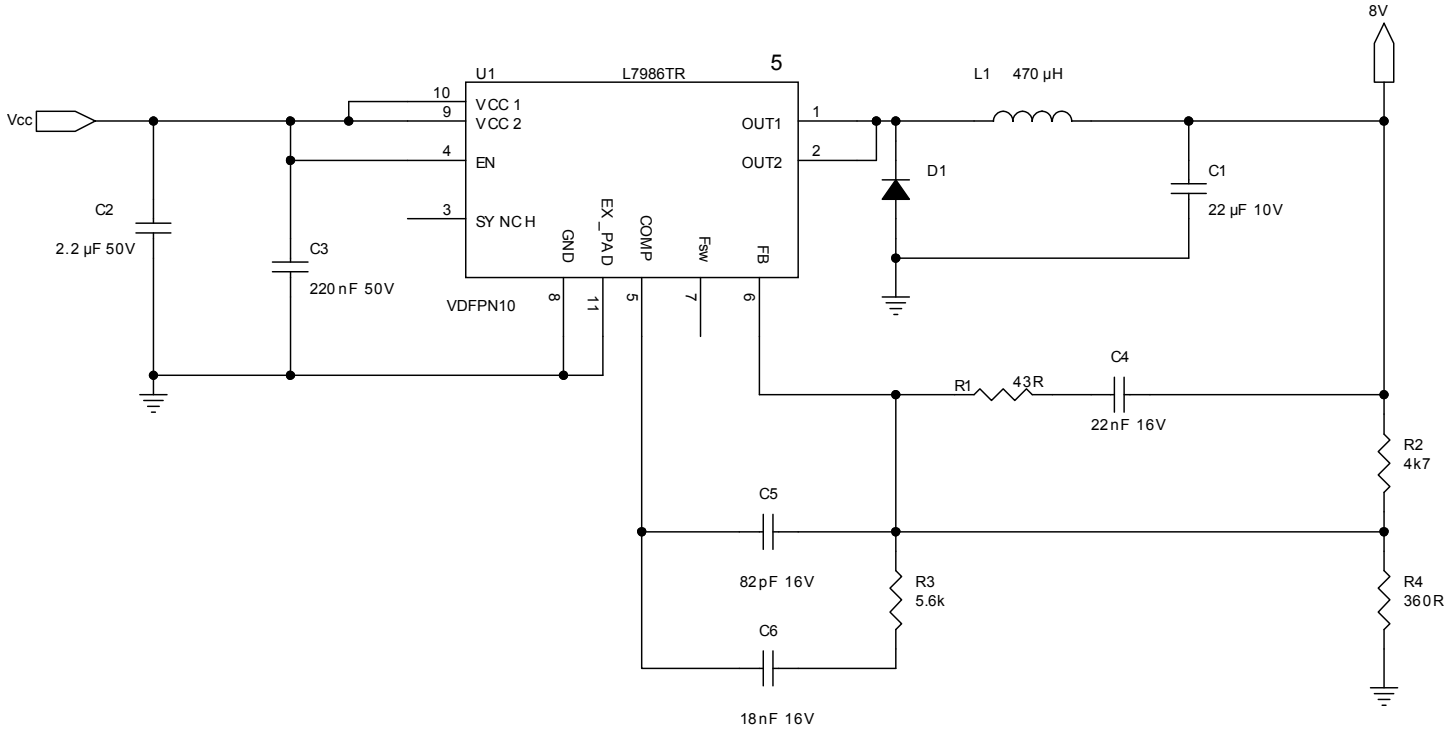

Figure 4. STEVAL-IDP003V1 circuit schematic (2 of 6) - vibration sensor

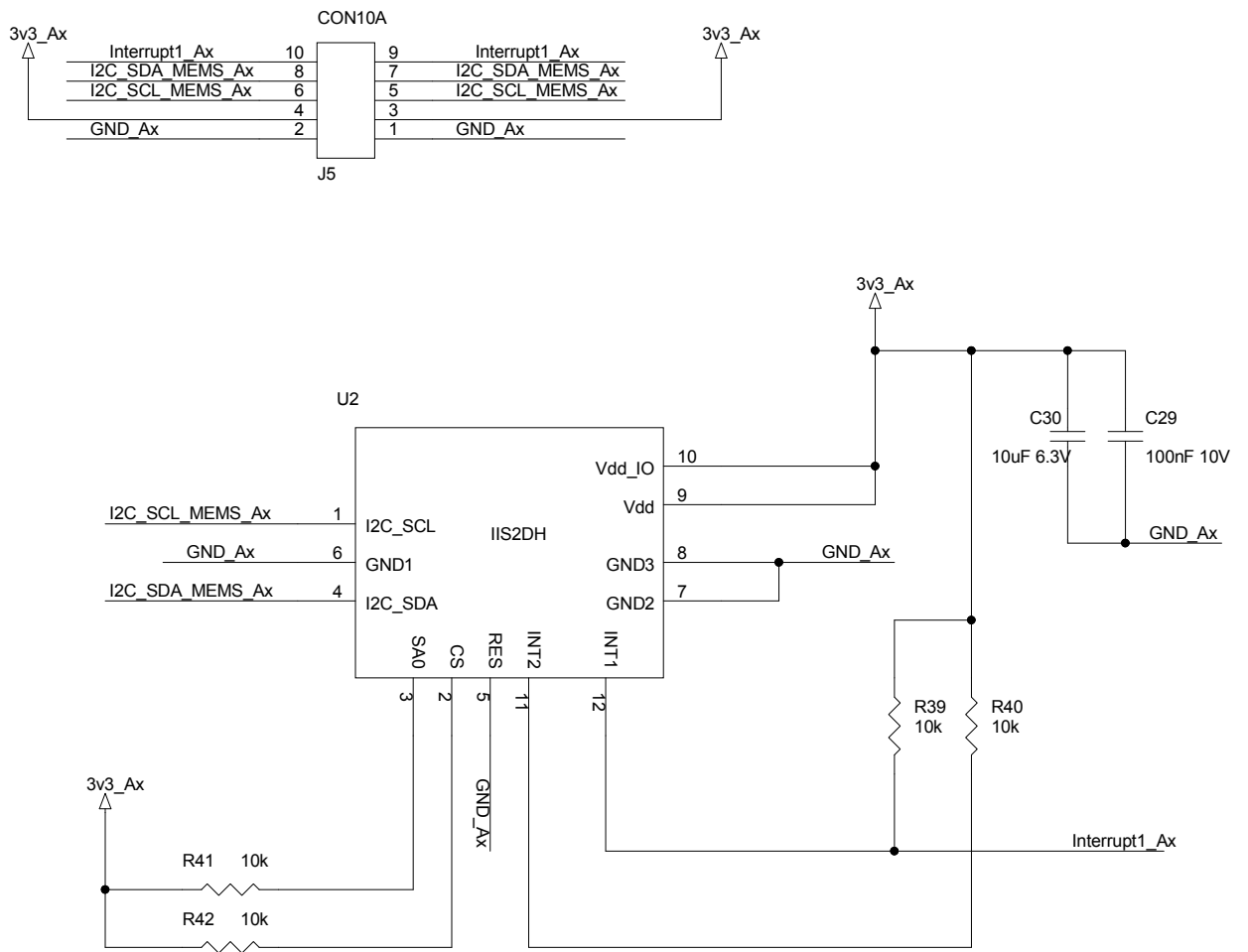

Figure 5. STEVAL-IDP003V1 circuit schematic (3 of 6) - accelerometer sensor

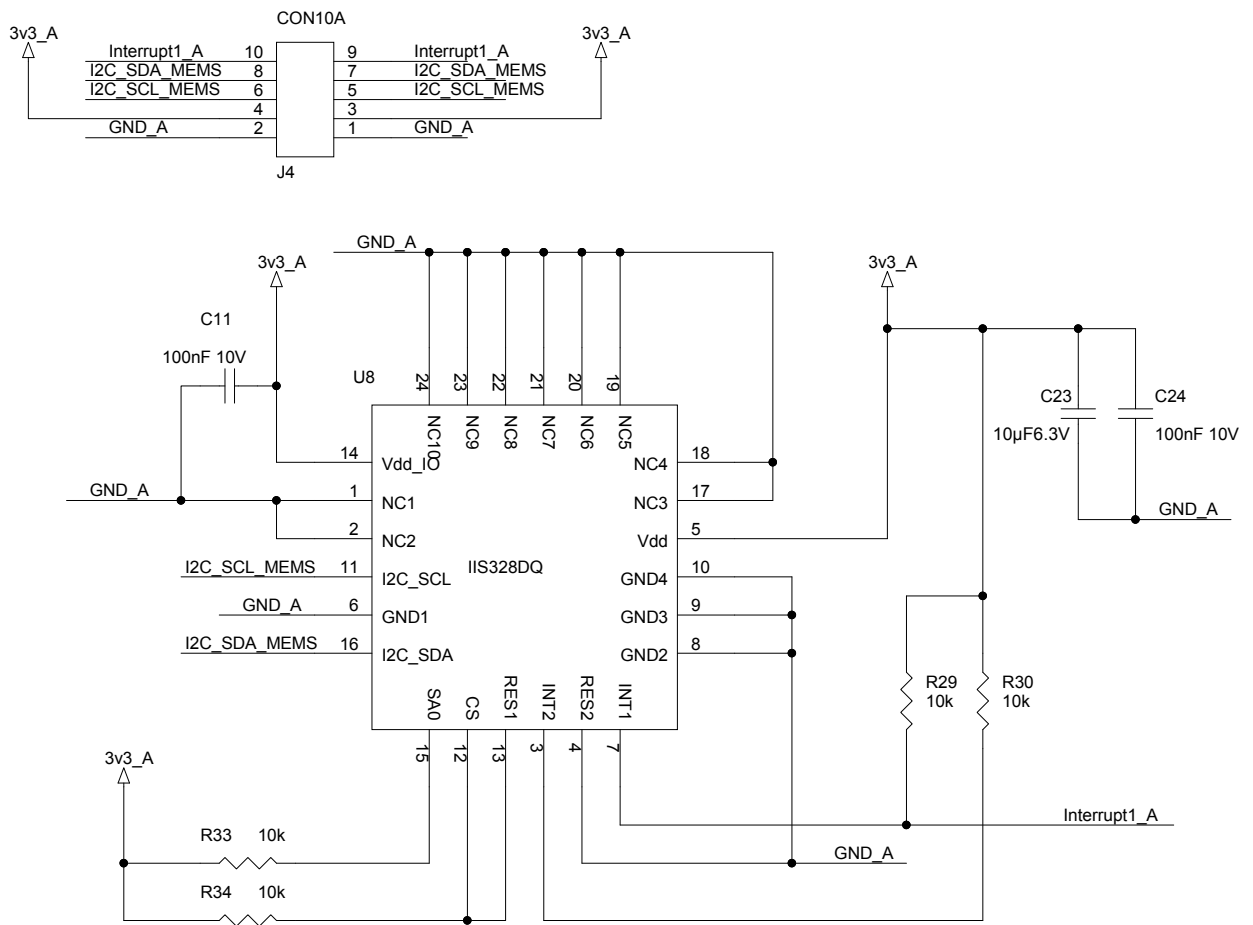

Figure 6. STEVAL-IDP003V1 circuit schematic (4 of 6) - temperature sensor

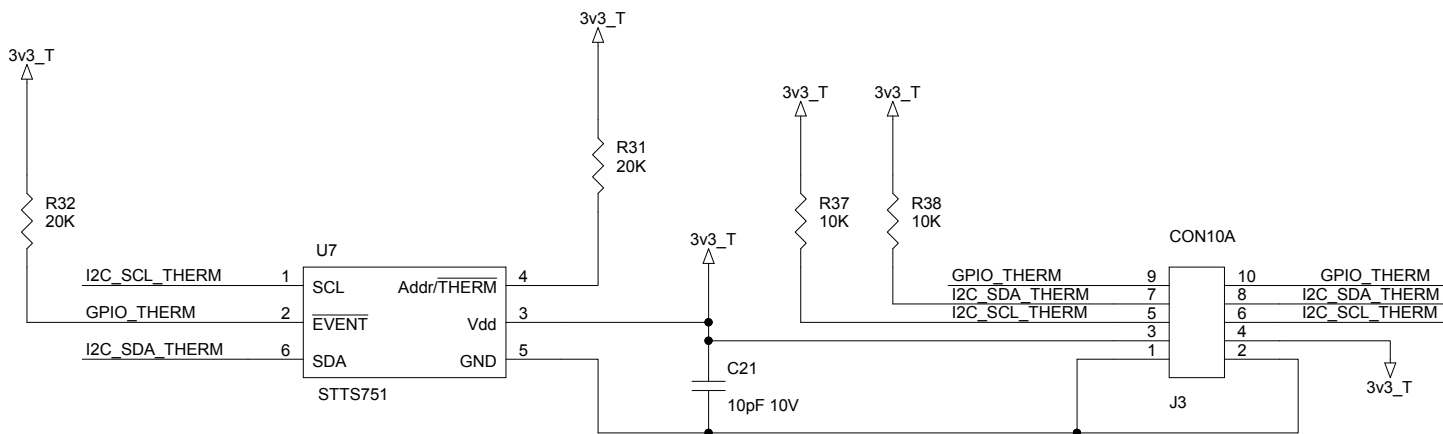
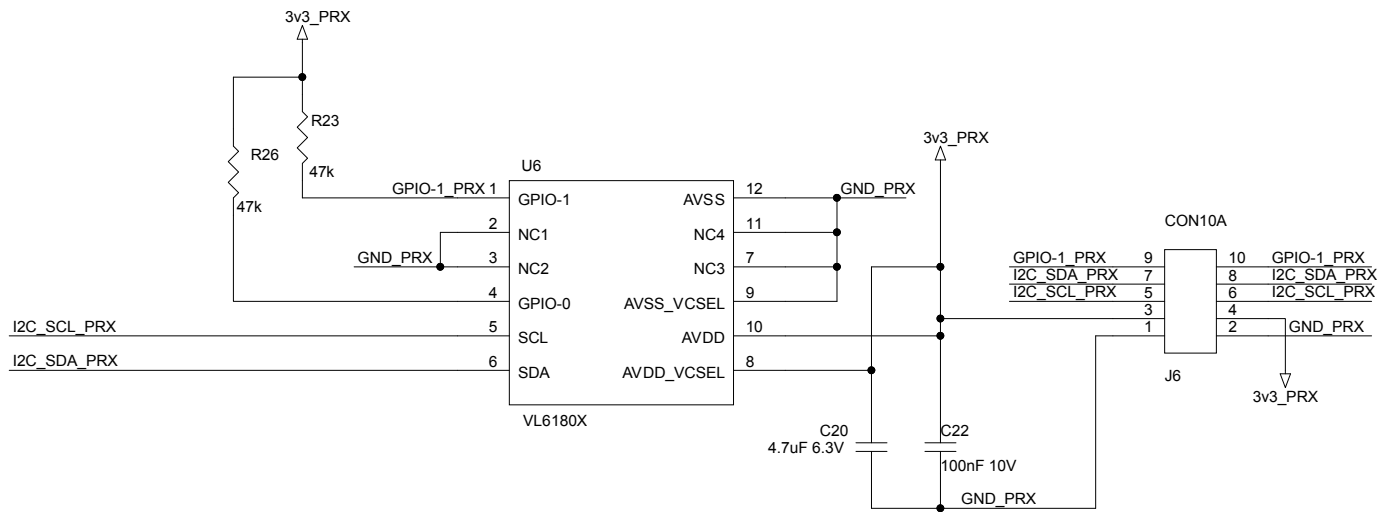
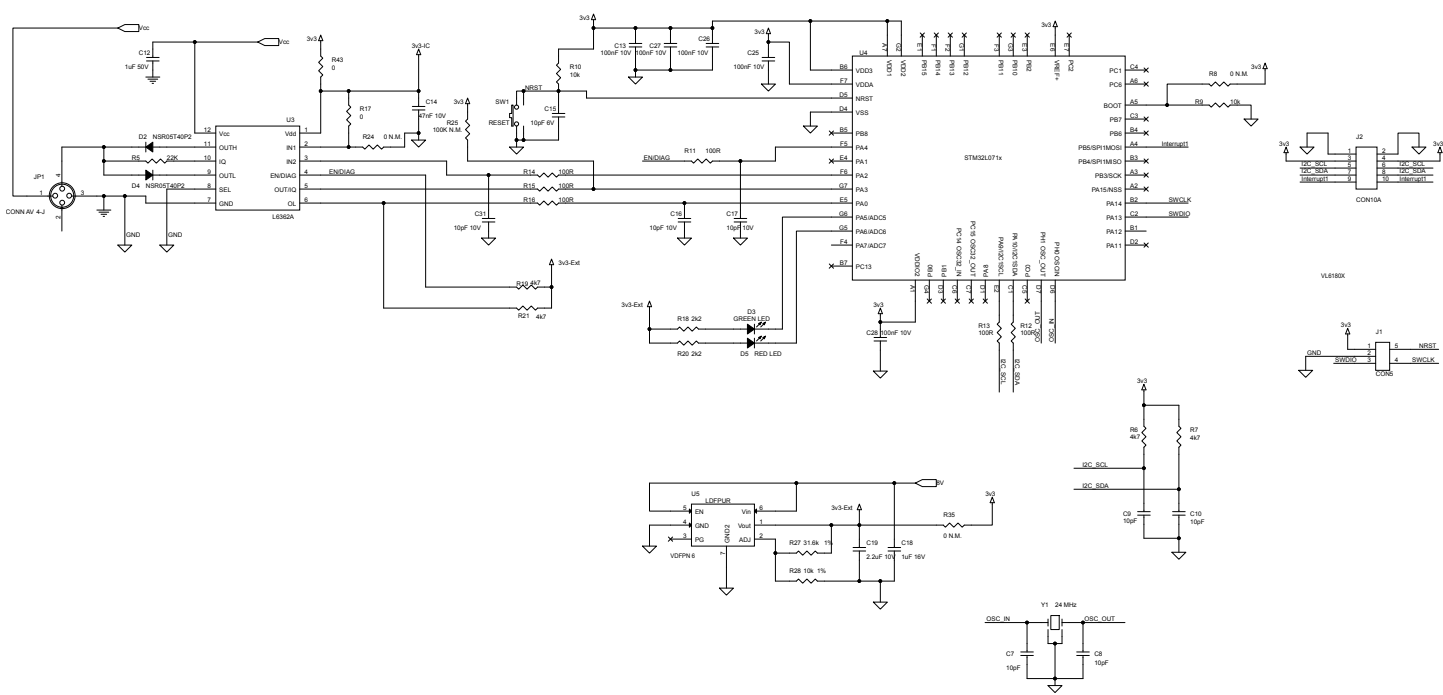

Figure 7. STEVAL-IDP003V1 circuit schematic (5 of 6) - proximity sensor

Figure 8. STEVAL-IDP003V1 circuit schematic (6 of 6) - microcontroller

Revision history

Table 1. Document revision history

Date	Version	Changes
09-Jun-2017	1	Initial release.
25-Oct-2017	2	Updated Figure 6. Minor text changes.
02-Dec-2020	3	Updated cover page image. Added cover page product summary. Minor text changes.