

Low data-rate, short-range USB dongle transceiver in 433 MHz band based on the SPIRIT1

Data brief



Description

The STEVAL-IDS001V3 demonstration board is based on the SPIRIT1, which is a sub-GHz low power, low data-rate transceiver suitable for ISM bands and Wireless M-BUS. The board is equipped with an STM32L low power microcontroller to control the SPIRIT1. The board also features a USB connector for PC GUI interaction and firmware update. An optional JTAG connector (not mounted) allows the development of specific firmware on the microcontroller.

Features

- SPIRIT1 low power sub-GHz transceiver integrated in a USB dongle for direct PC connection
- External components tuned for 433 MHz band
- STM32L microcontroller
- Suitable for Wireless M-BUS systems
- Associated SPIRIT1 development kit includes: documentation, firmware for STM32L and GUI
- Optional debug connector (not mounted)
- USB interface
- Modulation schemes: 2-FSK, GFSK, MSK, GMSK, OOK, and ASK
- Air data rate: from 1 to 500 kbps
- Very low power consumption (9 mA RX and 21 mA TX at +11 dBm)
- Excellent receiver sensitivity performance (up to -118 dBm)
- Low duty cycle RX/TX operation mode
- Automatic acknowledgment, retransmission, and timeout protocol engine
- AES 128-bit encryption co-processor
- SPI interface for microcontroller
- RoHS compliant

1 Schematic diagram

Figure 1. SPIRIT1 circuit schematic

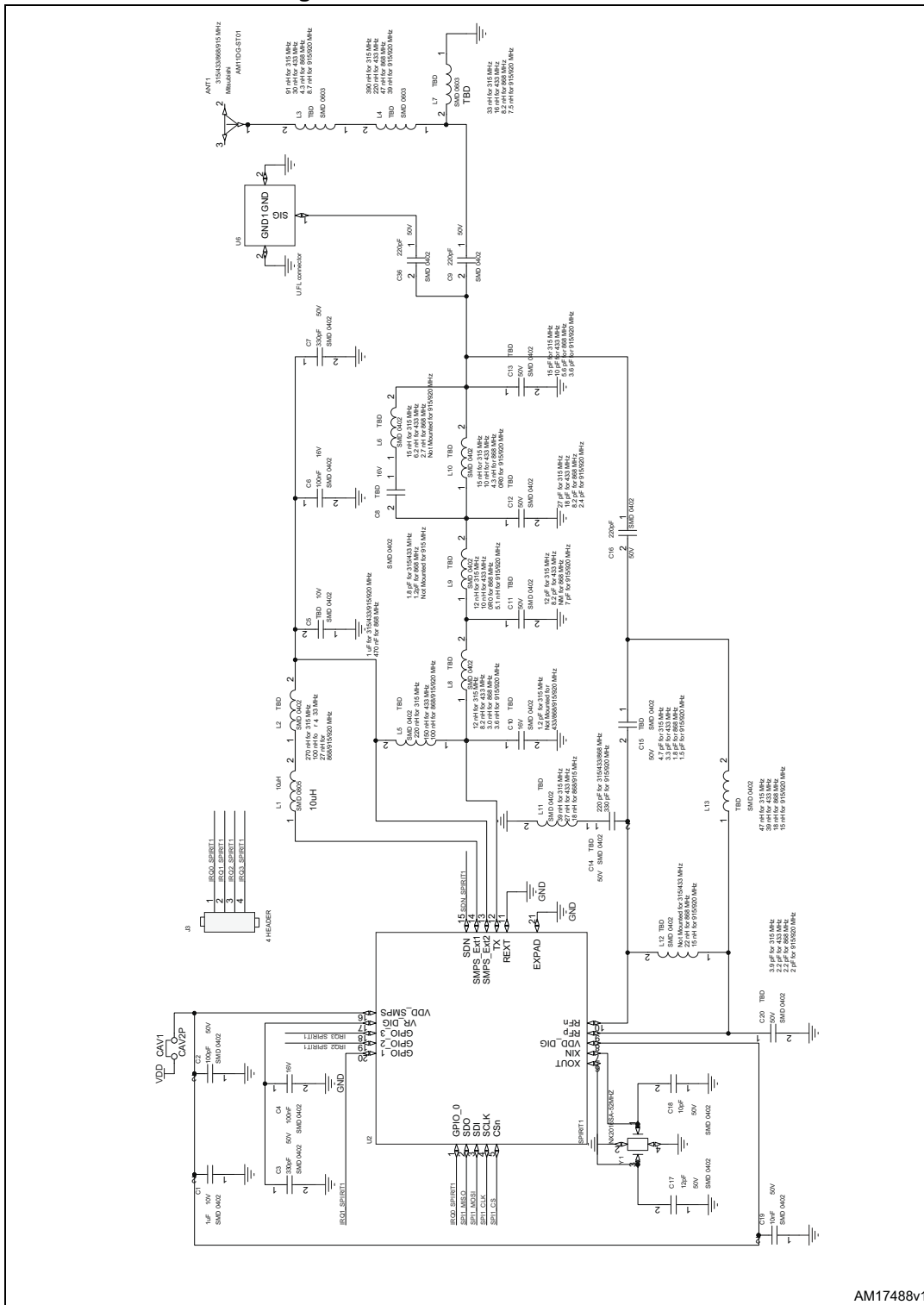

AM17488v1



Figure 2. Oscillator circuit schematic

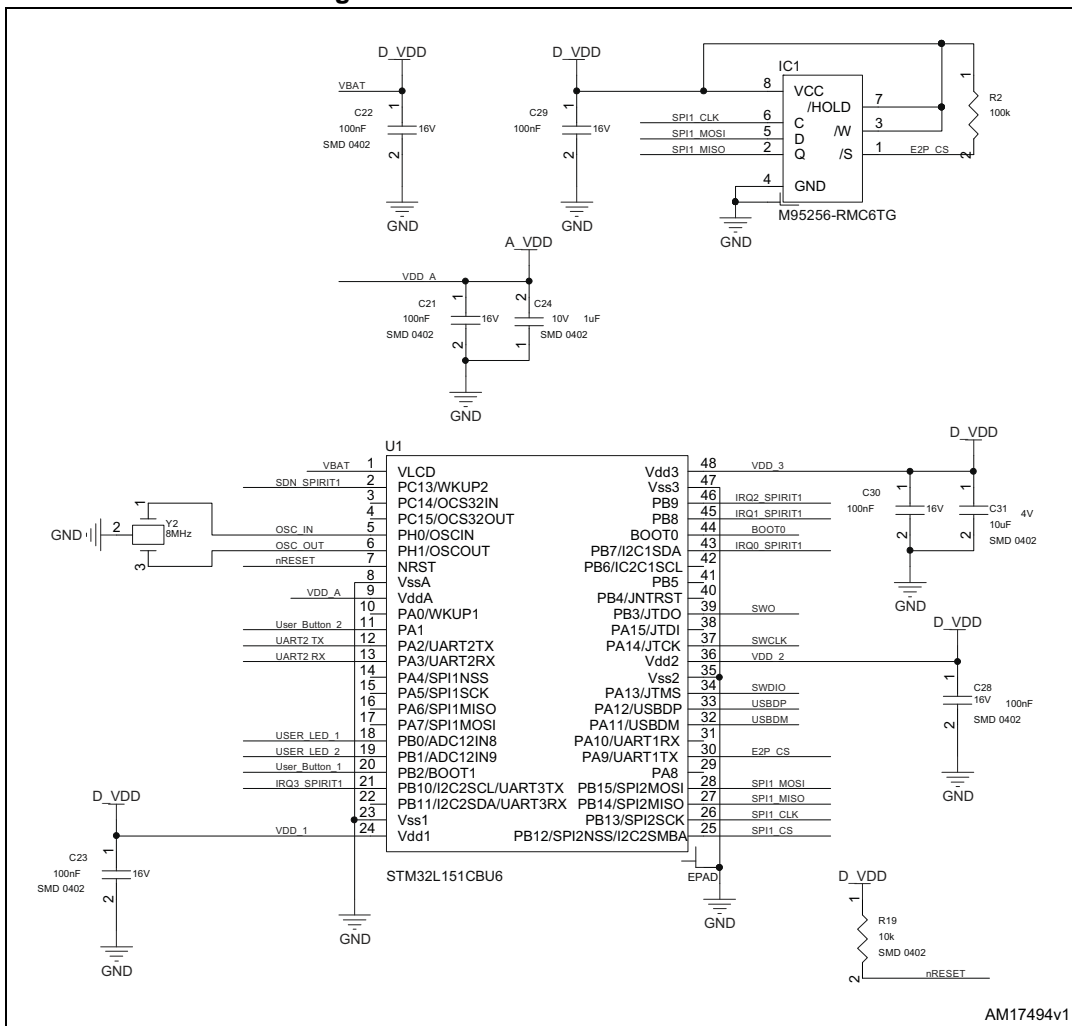

AM17494v1

Figure 3. SWD circuit schematic

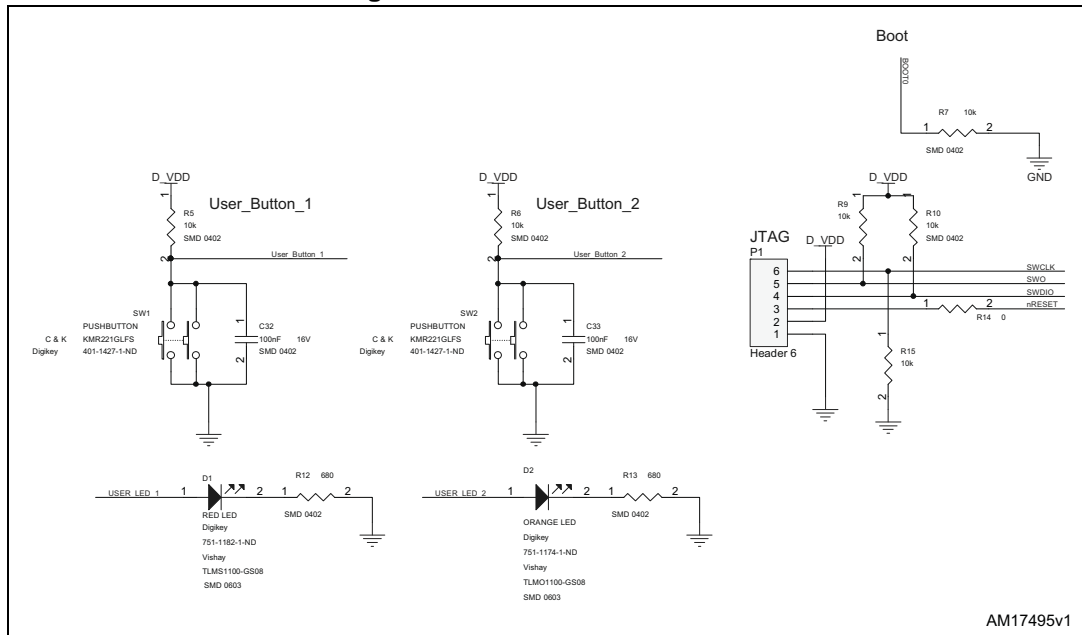

Figure 4. USB circuit schematic

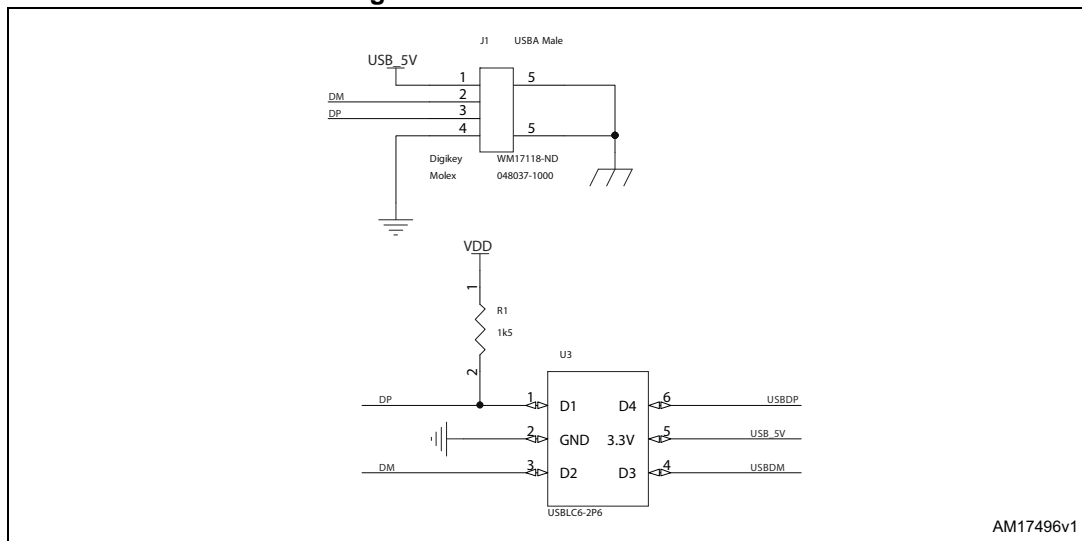
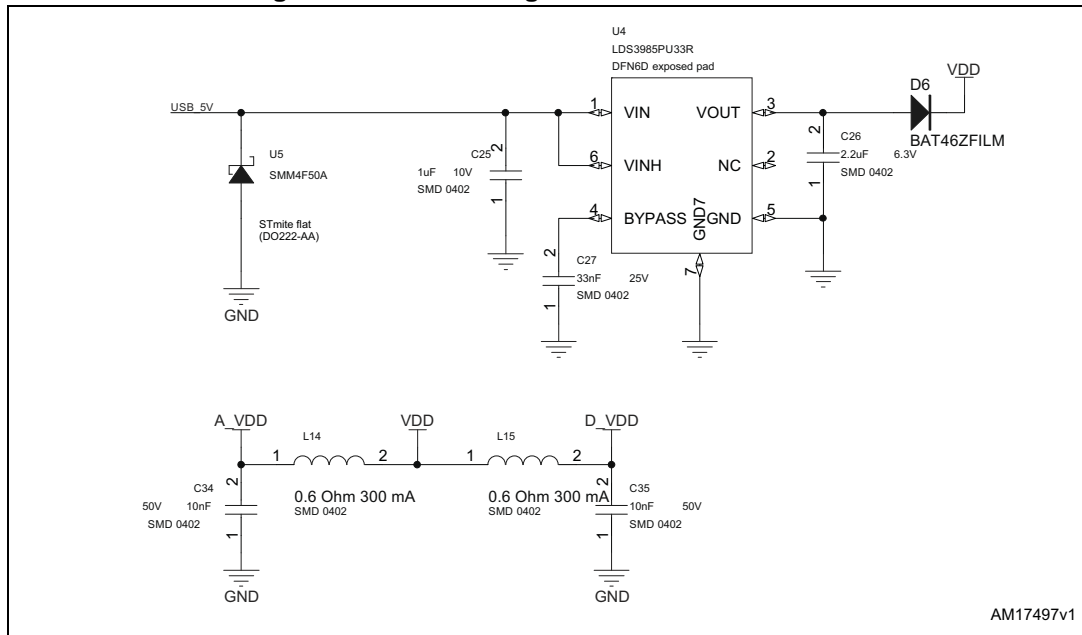

Figure 5. Power management circuit schematic



2 Revision history

Table 1. Document revision history

Date	Revision	Changes
28-Jun-2013	1	Initial release.