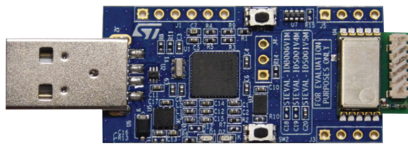


868 MHz RF USB dongle based on the SPSGRF-868 transceiver module



Features

- Based on SPSGRF-868 module which features:
 - low data rate, low-power, sub-1GHz SPIRIT1 transceiver
 - integrated balun (BALF-SPI-01D3)
 - chip antenna
- On-board STM32L151CBU6A ultra low power ARM® Cortex®-M3 microcontroller
- Modulation schemes: 2-FSK, GFSK, MSK, GMSK, OOK and ASK
- Air data rate: from 1 to 500 kbps
- Fully compliant with the SPIRIT1 development kit firmware and GUI
- Debug connector
- USB interface

Description

The STEVAL-IDS001V4M evaluation board is based on the SPSGRF-868 CE certified RF module with the SPIRIT1 low-power Sub 1GHz transceiver and embeds the STM32L151CBU6A ultra low-power ARM Cortex-M3 MCU.

The SPSGRF-868 module integrates the BALF-SPI-01D3 match balun and a chip antenna, and operates in the 868 MHz ISM band.

The STEVAL-IDS001V4M evaluation board features a USB connector for PC-GUI interaction and firmware updates, and an SWD connector for specific firmware development.

Product summary	
868 MHz RF USB dongle based on the SPSGRF-868 transceiver module	STEVAL-IDS001V4M
Sub-GHz low power programmable RF transceiver module	SPSGRF-868
Match balun with integrated harmonic filter	BALF-SPI-01D3
Low data rate, low power Sub 1GHz transceiver	SPIRIT1
Ultra-low-power ARM Cortex-M3 MCU	STM32L151CBU6A
Applications	Smart City Smart Home Industrial Tools Wireless connectivity

1 Schematic diagrams

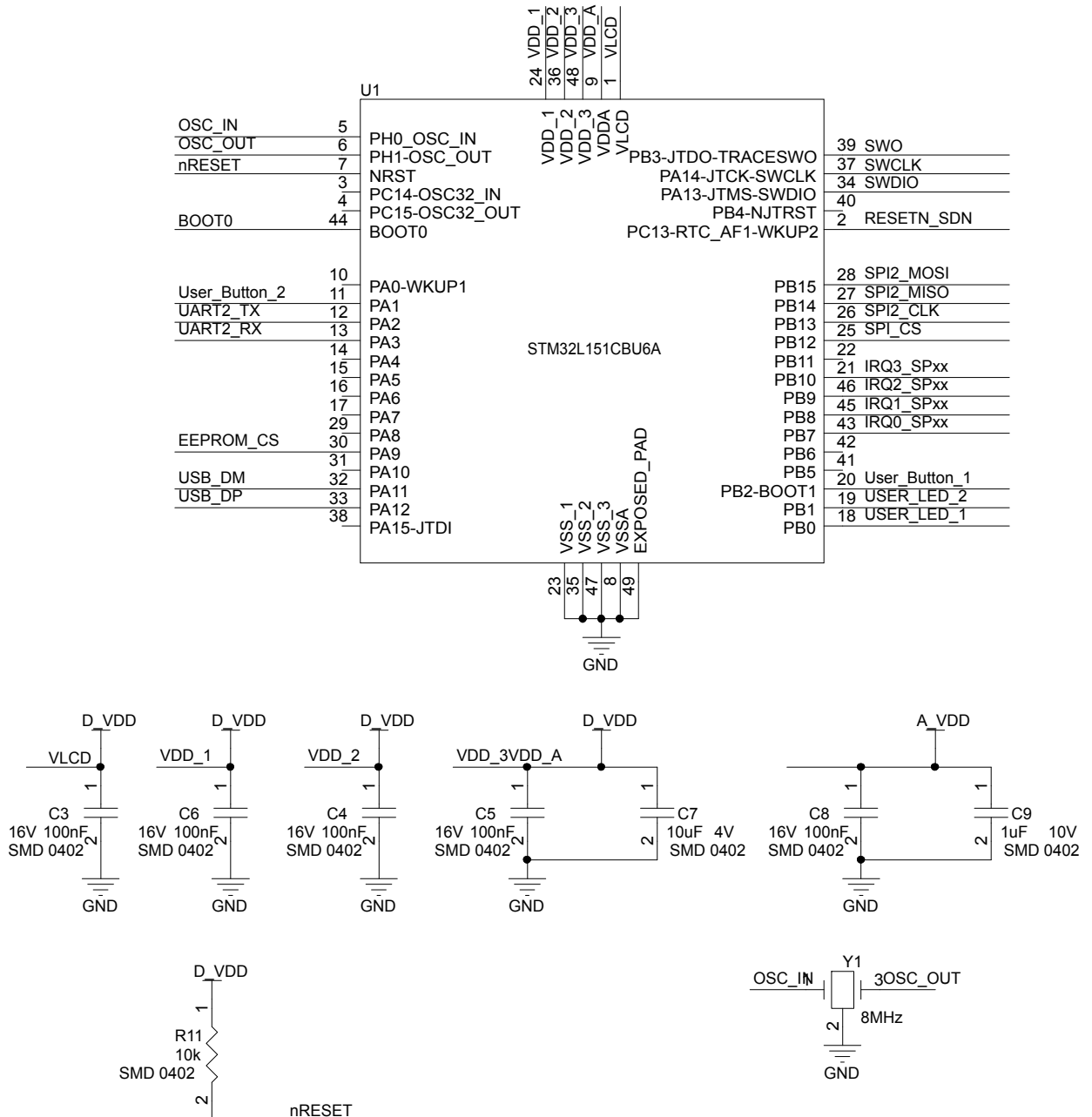
Figure 1. STEVAL-IDS001V4M circuit schematic - MCU oscillator and voltage


Figure 2. STEVAL-IDS001V4M circuit schematic - SWD, boot, user LEDs and user buttons

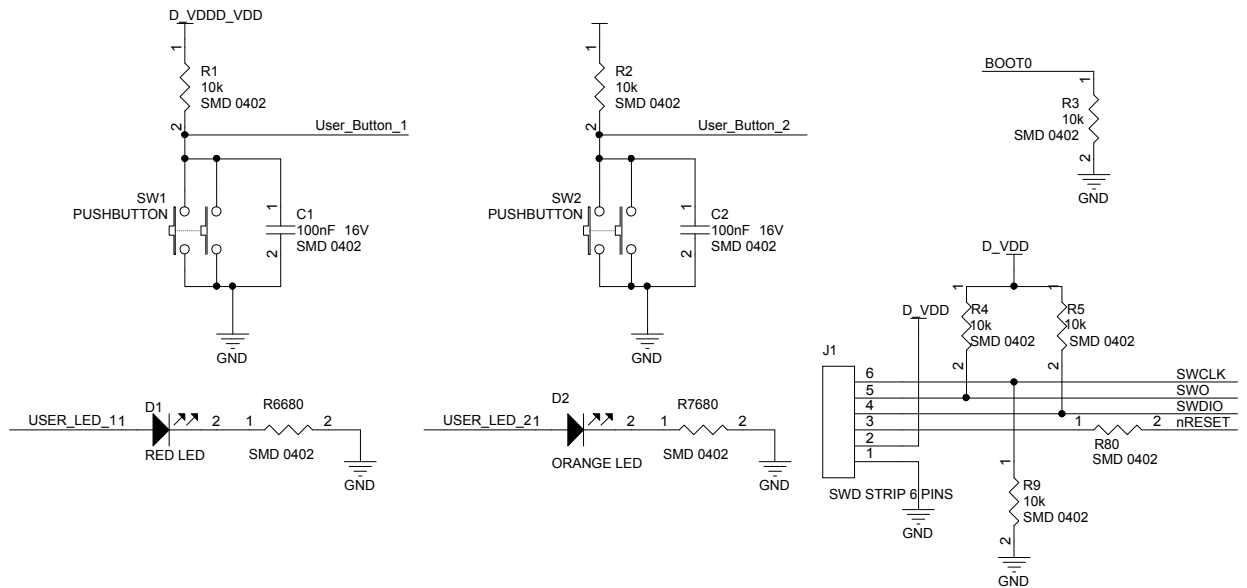


Figure 3. STEVAL-IDS001V4M circuit schematic - USB and EEPROM

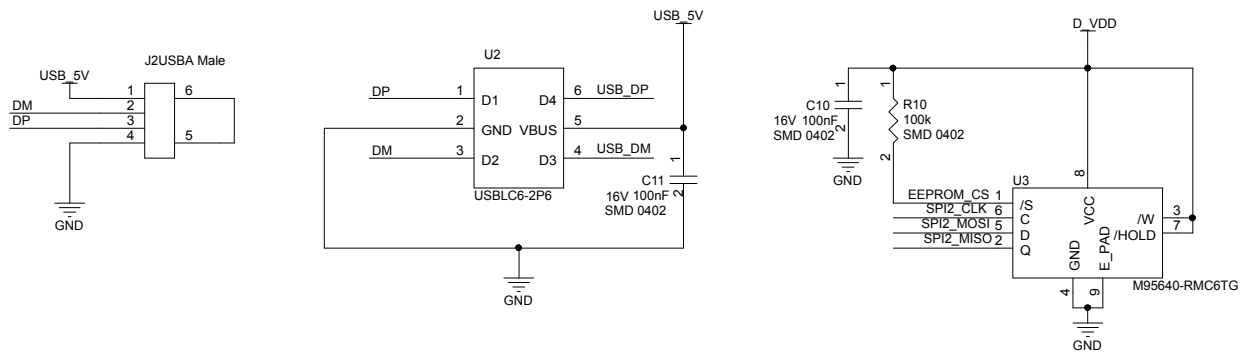
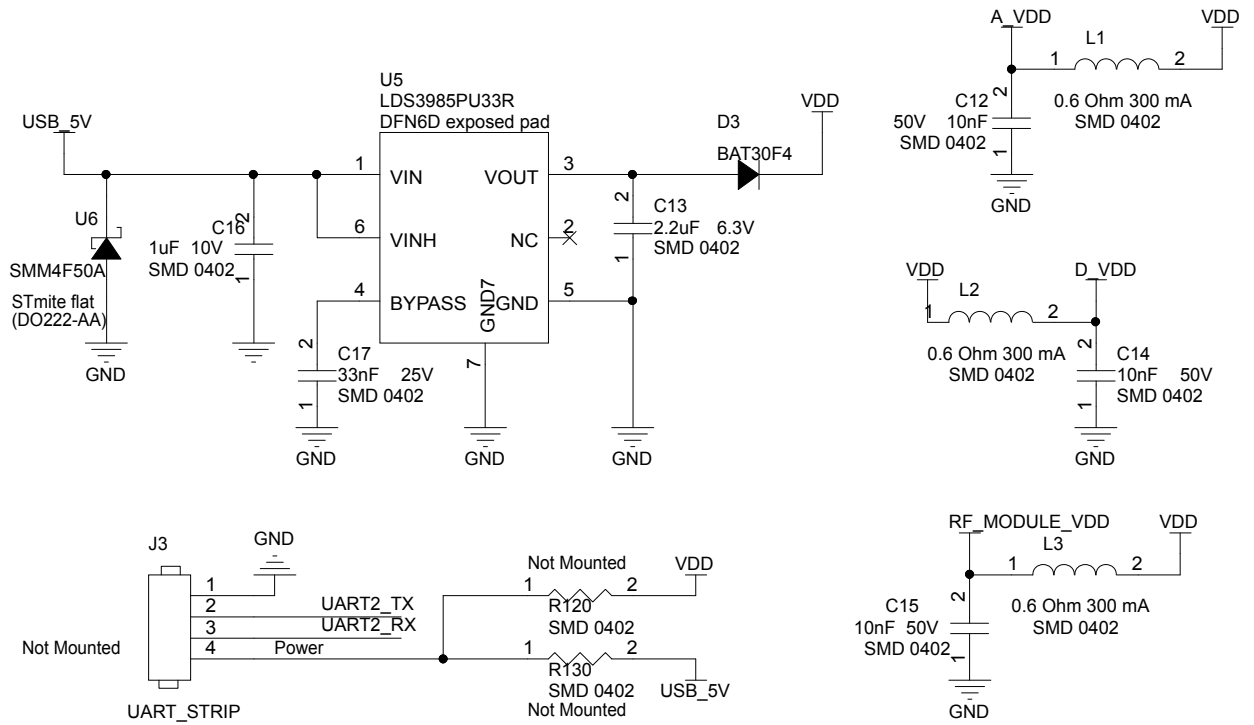
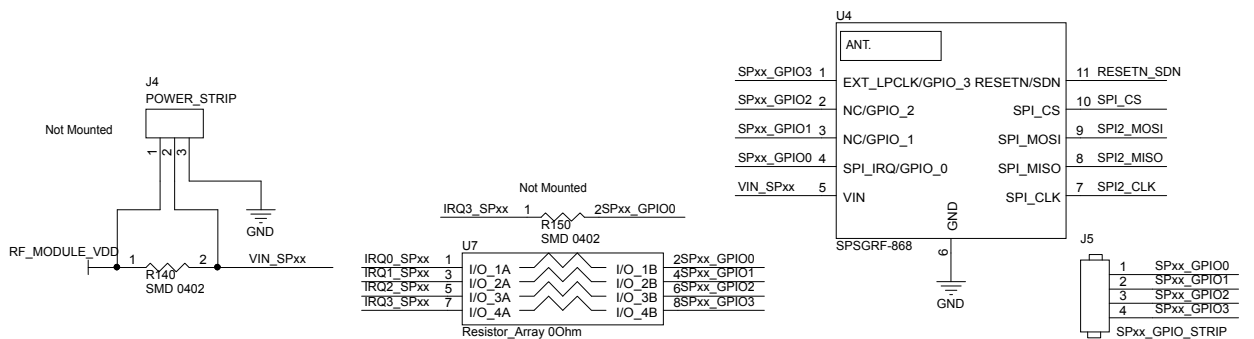


Figure 4. STEVAL-IDS001V4M circuit schematic - power management stage

Figure 5. STEVAL-IDS001V4M circuit schematic - RF module


Revision history

Table 1. Document revision history

Date	Version	Changes
02-Jul-2015	1	Initial release.
20-Apr-2020	2	Updated all document to reflect new MCU (STM32L151C8U6A) and new signal Schottky diode (BAT30F4).