



STEVAL-IFP021V1

5 V and 12 V power line protection based on STEF05 and STEF12 electronic fuses

Data brief

Features

- Input voltages: 5 V and 12 V
- Continuous current: 3.6 A (typ.) each
- Adjustable slew rate for output voltage
- Overvoltage clamp
- Undervoltage lockout
- Programmable short-circuit current limit
- Overload current limit
- Controlled output voltage ramp
- Thermal latch protection
- Fault condition flag
- Enable pin
- RoHS compliant

Description

The STEVAL-IFP021V1 demonstration board is based on the STEF05 and STEF12 electronic fuses (E-Fuses).

It is designed to help users evaluate the benefit of the complete protection offered by the E-Fuse family and to customize their own application.

The E-Fuse family of hot-swap converters is designed to replace the mechanical fuses on low voltage power lines.

The STEF05 and STEF12 are integrated electronic fuses optimized for monitoring output current and input voltage.

Connected in series to the 5 V/12 V rails, they are capable of protecting the electronic circuitry on the output from overcurrent and overvoltage.

The turn-on time is programmable by means of an external capacitor, allowing control of the inrush current at startup and during hot-swaps.

When an overload condition occurs, the E-Fuse limits the output current to a predefined safe value. If the anomalous overload condition

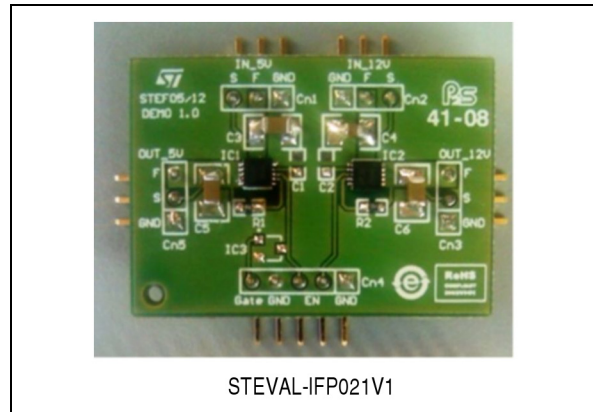

persists, it goes into an open state, disconnecting the load from the power supply.

If a continuous short-circuit is present on the board, when power is re-applied the E-Fuse initially limits the output current to a safe value, and then again goes into an open state.

Both devices are equipped with a thermal protection circuit.

The intervention of the thermal protection is signaled to the board monitoring circuits through a signal on the enable/fault pin that can be connected to other parts belonging to the same family to cause a simultaneous shutdown during failure events.

Unlike mechanical fuses, which must be physically replaced after a single event, E-Fuses do not degrade in their performance after short-circuit/thermal protection interventions and can be reset either by re-cycling the supply voltage or by using the enable pin.

1 Circuit schematic

Figure 1. STEVAL-IFP021V1 circuit diagram

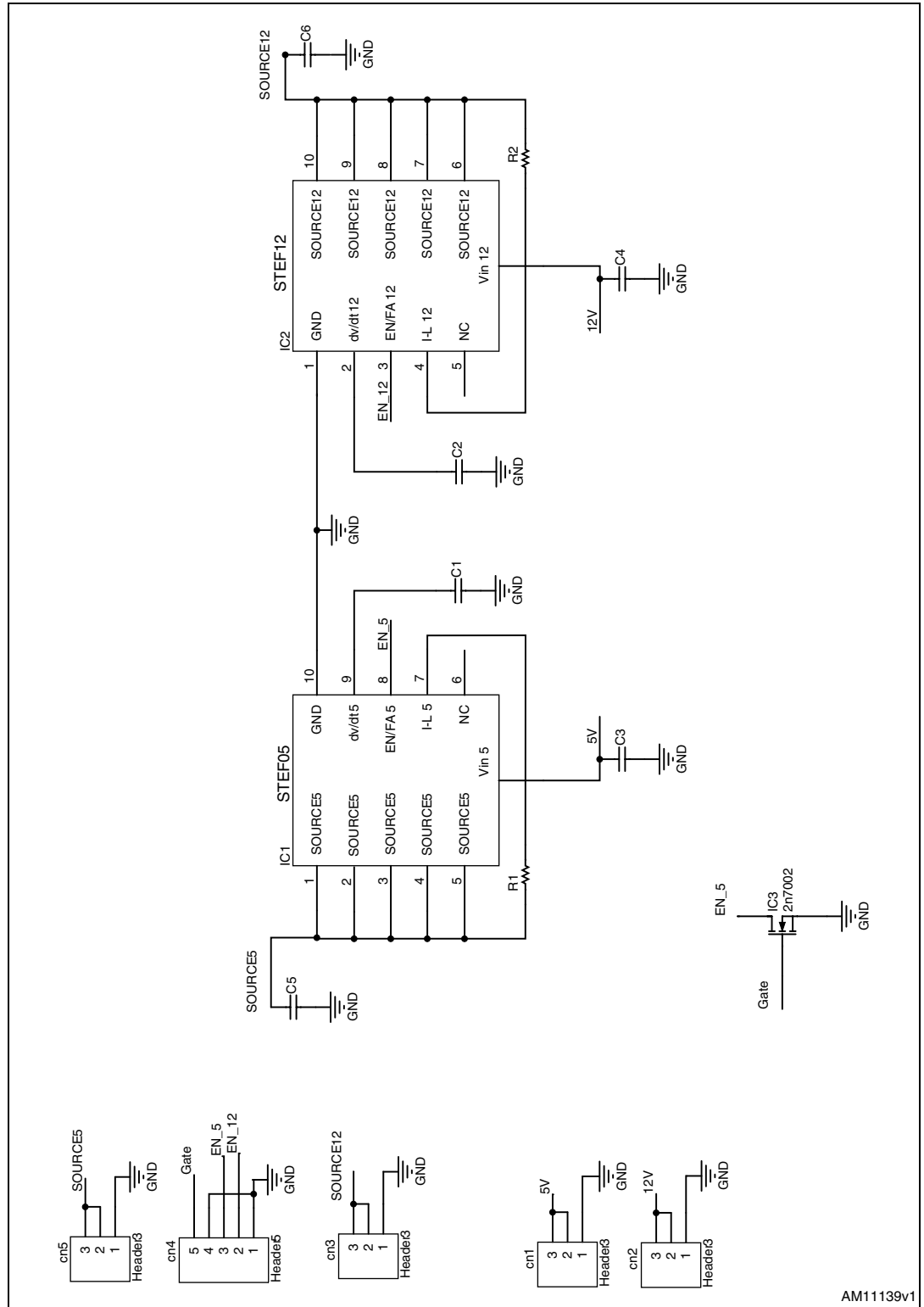

2 Revision history

Table 1. Document revision history

Date	Revision	Changes
27-Jan-2012	1	Initial release.