

Isolated and non-isolated digital inputs on evaluation board based on CLT03-2Q3 self-powered current limited termination device



Features

- 2 isolated high-side / low-side digital inputs
- 2 non-isolated high-side digital inputs
- 60 V and reverse input plugin capable
- No power supply required
- Safety test pulse
- High EMI robustness thanks to integrated digital filter
- IEC61131-2 type 1 and type 3 compliant
- RoHS compliant

Description

The STEVAL-IFP035V1 evaluation board is designed to help you evaluate circuit protection strategies for factory automation using digital-input current limiters between industrial sensor devices and processing units such as programmable logic controllers (PLC).

The board embeds two independent [CLT03-2Q3](#) self-powered digital input current limiters, each with two isolated channels able to drive isolated opto-coupler or non-isolated LVTTTL digital input terminations. These devices also feature reduced power dissipation and improved EMI robustness for safer and more reliable operation, and to allow designers to build solutions with greater I/O module density.

The board also observes other standard industry requirements such as reverse polarity operation and one-minute overvoltage tolerance, and jumpers are included to generate test pulses along any of the lines to verify normal operation.



Product summary	
evaluation board based on CLT03-2Q3 self-powered current limited termination device	STEVAL-IFP035V1
Self powered digital input current limiter	CLT03-2Q3
Application scenario	Safety PLC

1 Overview

The **STEVAL-IFP035V1** board has four input connectors for four industrial digital sensors, such as proximity, capacitive, optical, ultrasonic, and touch sensors. Two of the inputs are intended for isolated lines with opto-couplers on the outputs, while two inputs are intended for standard non-isolated outputs. Each input then feeds directly into one of the two independent channels in one of the two embedded **CLT03-2Q3** current limiters.

The channels in the current limiter immediately rectify reverse polarity connections and proceed to filter and regulate the signals to deliver appropriate outputs for the isolated or non-isolated lines destined for the GPIO ports of a logic processor, such as microcontroller in a programmable logic controller (PLC).

The board also includes jumpers to allow you to send test pulses through any of the channels to verify normal operation.

Figure 2. Block diagram

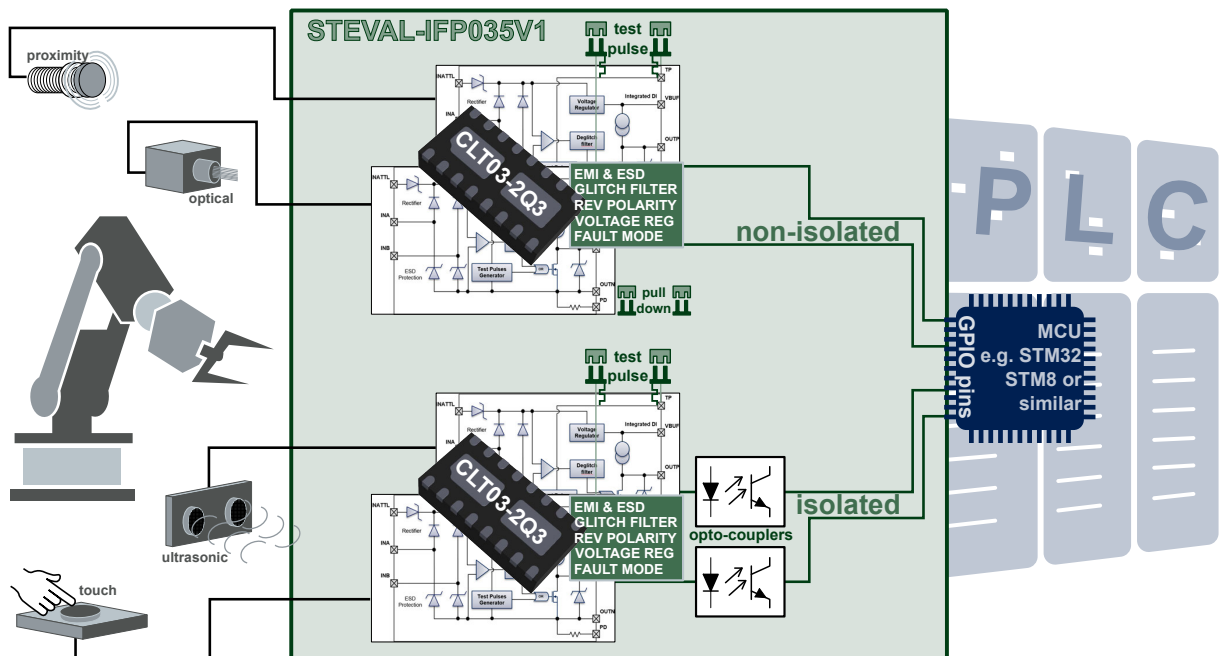

The input side of the **CLT03-2Q3** current limiter is characterized by certain voltage and current ranges that delimit ON and OFF regions, as well as transition regions between these logical high and low states. The device enters Fault Mode when the input voltage exceeds 30 V.

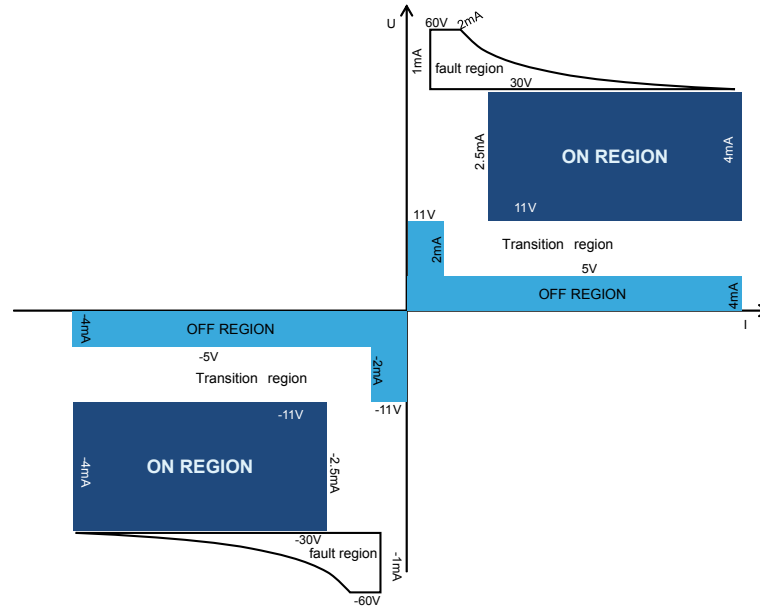
Figure 3. Input operation

The current limiter delivers stable outputs in discrete ranges for both the isolated and non-isolated outputs, so that a downstream logic processor can reliably differentiate digital high and low logic signals from the factory automation sensor inputs.

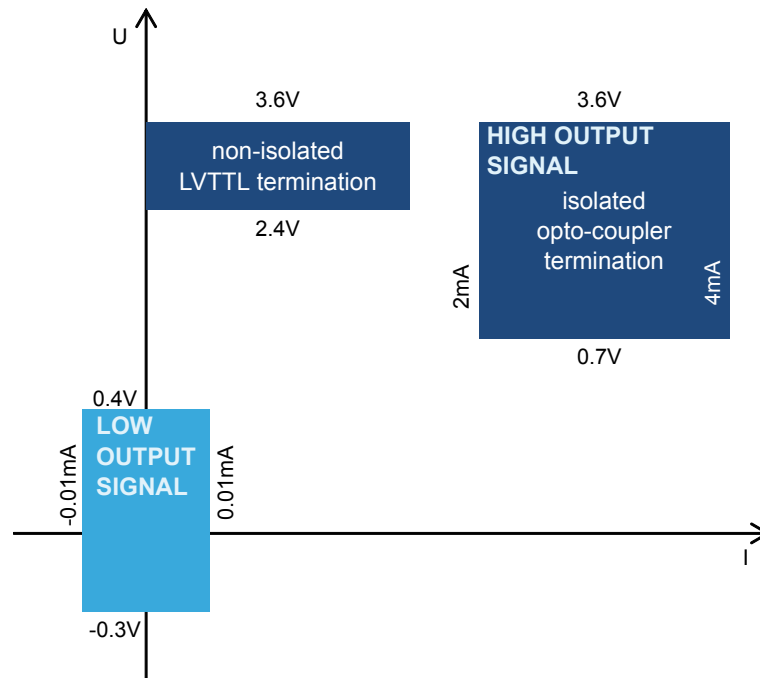
Figure 4. Output operation

RELATED LINKS

For more information on the CLT03-2Q3 current limited termination device, visit the product web folder on the ST website
 Visit the ST Factory Automation application page for more information on ST's range of industrial solutions

2 Schematic diagrams

Figure 5. STEVAL-IFP035V1 schematic - non-isolated digital output

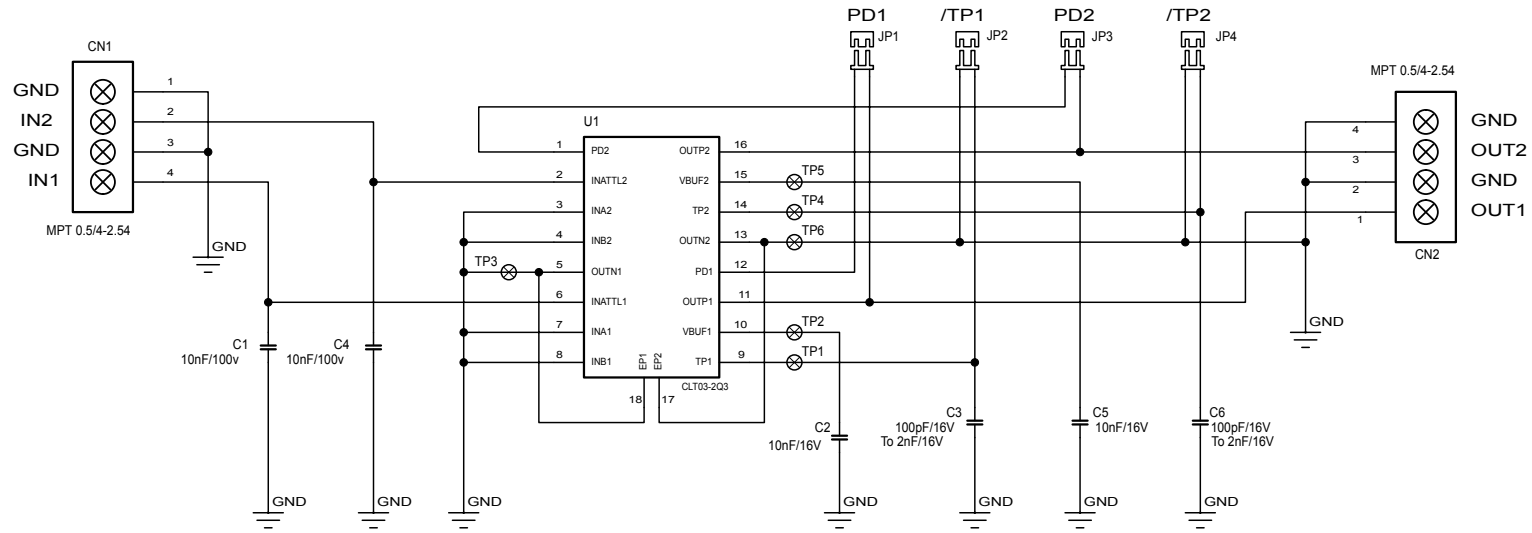
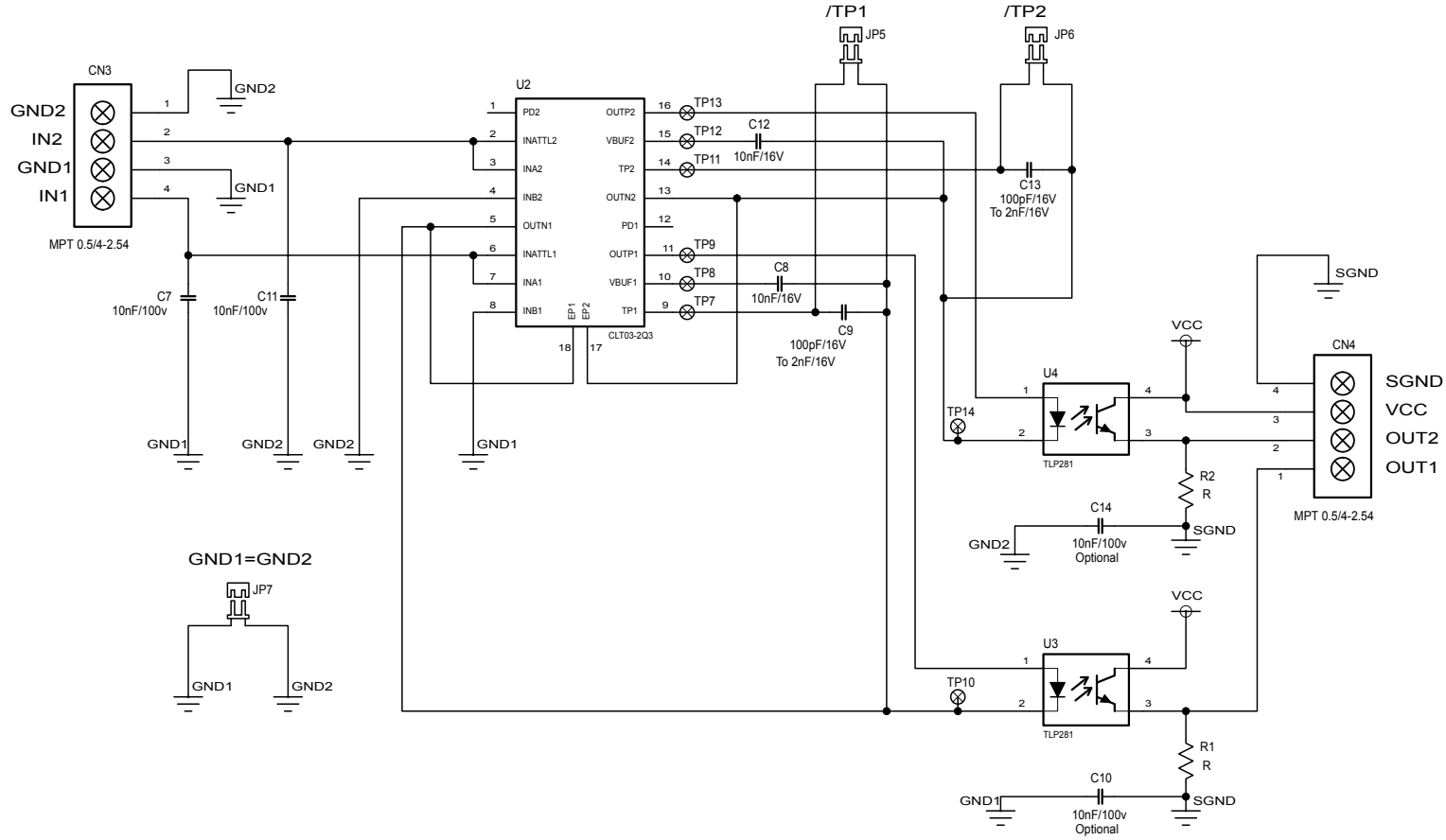

Figure 6. STEVAL-IFP035V1 schematic - isolated digital input



Revision history

Table 1. Document revision history

Date	Version	Changes
27-May-2019	1	Initial release.