

Industrial digital output expansion board based on IPS2050H in a QFN48L package

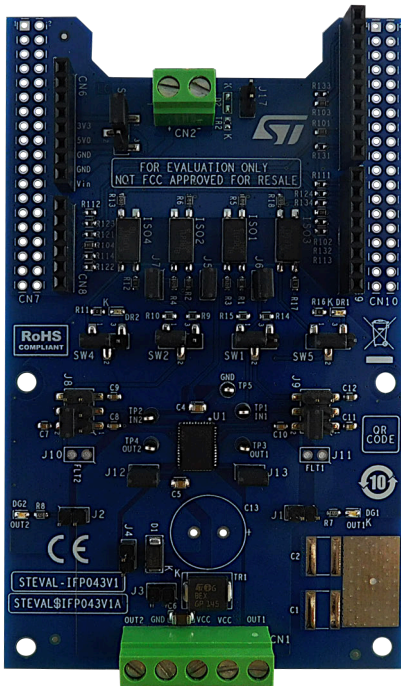

Features

- Based on **IPS2050H** dual high-side switch, which features:
 - Operating range up to 60 V/2.5 A
 - Low power dissipation ($R_{ON(MAX)} = 50\text{ m}\Omega$)
 - Fast decay for inductive loads
 - Smart driving of capacitive load
 - Under-voltage lock-out
 - Per-channel overload and over-temperature protections
 - QFN48L 8x6 mm package
- Application board operating range: 8 to 33 V/0 to 2.5 A
- Extended voltage operating range (J3 open) up to 60 V
- Green LEDs for output on/off status
- Red LEDs for per-channel diagnostic (overload and overheating)
- 5 kV galvanic isolation
- Supply rail reverse polarity protection
- Compatible with **STM32 Nucleo** development boards
- Equipped with Arduino UNO R3 connectors
- CE certified
- RoHS and China RoHS compliant
- Not FCC approved for resale

Description

The **STEVAL-IFP043V1** is an industrial digital output expansion board. It provides a powerful and flexible environment for the evaluation of the driving and diagnostic capabilities of the **IPS2050H** (dual high-side smart power solid state relay) in a digital output module connected to 2.5 A (max.) industrial loads.

The **STEVAL-IFP043V1** can interface with the microcontroller on the **STM32 Nucleo** via 5 kV optocouplers driven by GPIO pins, Arduino UNO R3 (default configuration) and ST morpho (optional, not mounted) connectors.

The expansion board can be connected to either a **NUCLEO-F401RE** or **NUCLEO-G431RB** development board.

It is also possible to evaluate a system composed by up to four stacked **STEVAL-IFP043V1** expansion boards.

As an example, a system with four **STEVAL-IFP043V1** expansion boards allows you to evaluate an eight-channel digital output module with 2.5 A (max.) capability each.

Product summary	
Industrial digital output expansion board based on IPS2050H	STEVAL-IFP043V1
Dual high-side smart power solid state relay	IPS2050HQ
Software expansion for STM32Cube driving industrial digital output based on IPS	X-CUBE-IPS
Applications	Programmable Logic Controllers

1 Schematic diagrams

Figure 1. STEVAL-IFP043V1 circuit schematic (1 of 2)

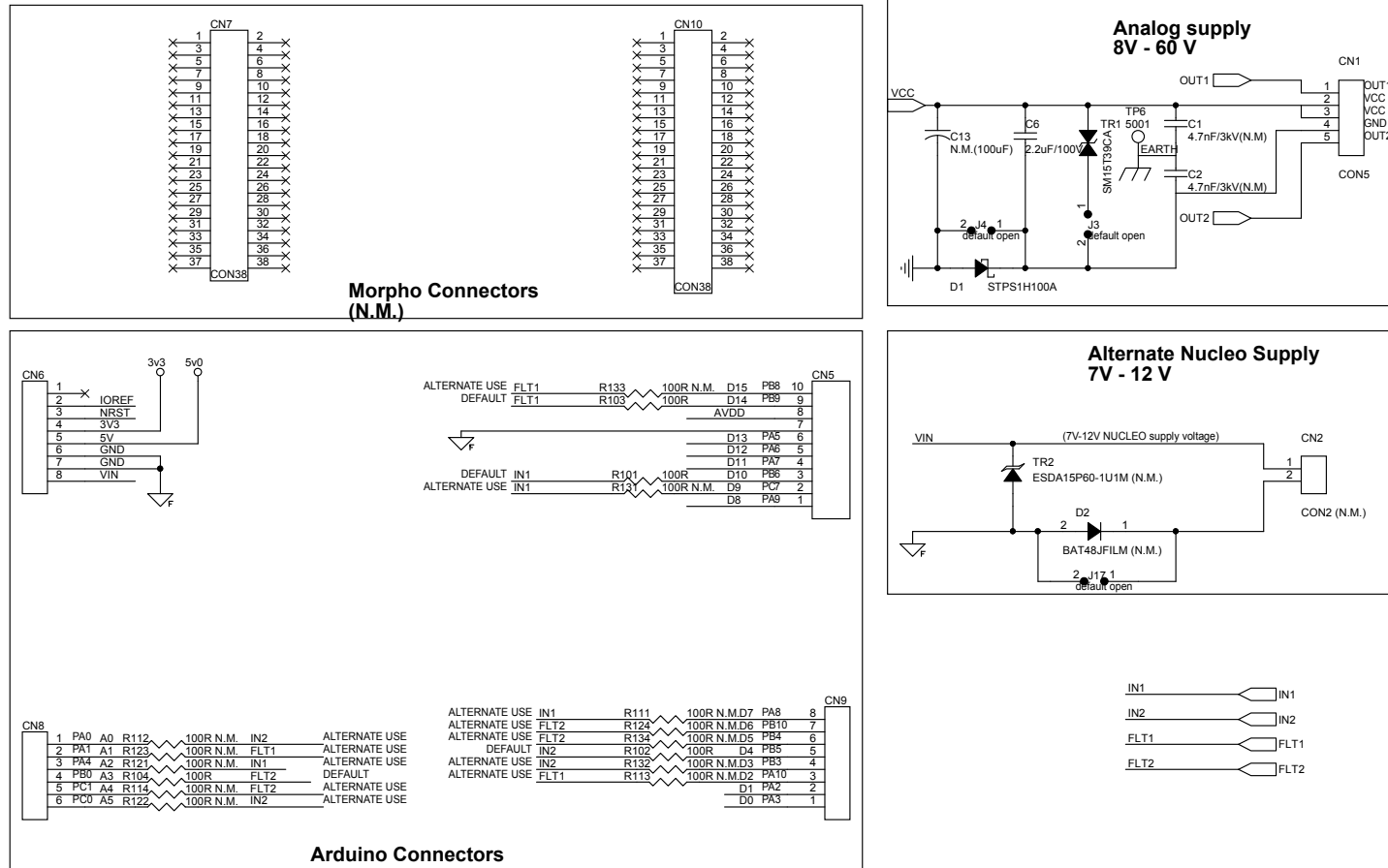
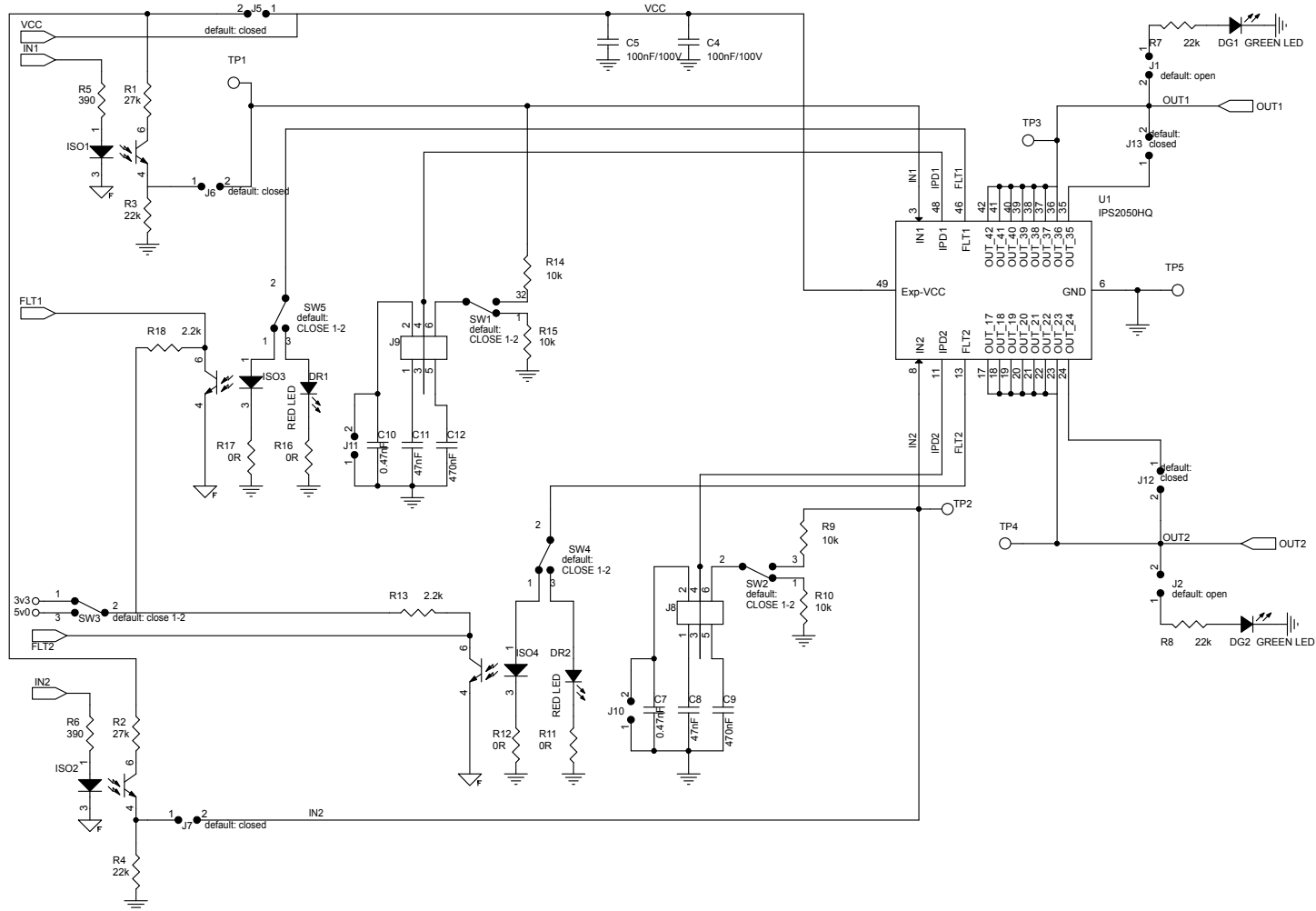

Figure 2. STEVAL-IFP043V1 circuit schematic (2 of 2)



2 Board versions

Table 1. STEVAL-IFP043V1 versions

PCB version	Schematic diagrams	Bill of materials
STEVAL\$IFP043V1A ⁽¹⁾	STEVAL\$IFP043V1A schematic diagrams	STEVAL\$IFP043V1A bill of materials

1. This code identifies the STEVAL-IFP043V1 evaluation board first version. It is printed on the board PCB.

Revision history

Table 2. Document revision history

Date	Revision	Changes
29-Aug-2022	1	Initial release.