

## Industrial digital output expansion board based on IPS1025H-32 in a QFN48L package

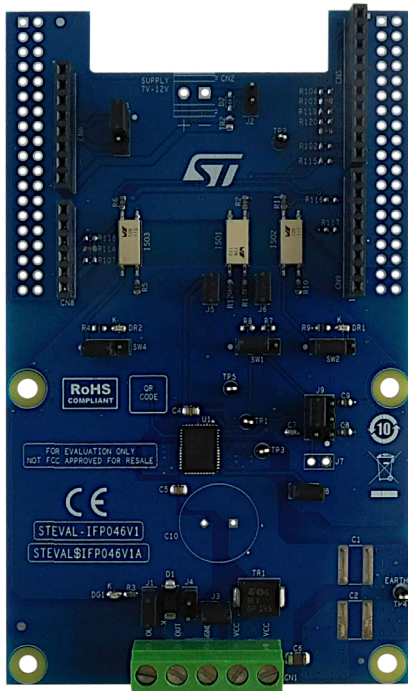

### Features

- Based on the [IPS1025H-32](#) single high-side switch, which features:
  - Operating range up to 60 V
  - Low-power dissipation ( $R_{ON(MAX)} = 25\text{ m}\Omega$ )
  - Fast decay for inductive loads
  - Smart driving of capacitive loads
  - Undervoltage lock-out
  - Overload and overtemperature protections
  - QFN48L 8x6 mm package
- Application board operating range: 8 to 33 V/0 to 5.7 A
- Extended voltage operating range (J3 open) up to 60 V
- Green LED for output on/off status
- Red LEDs for overload and overheating diagnostics
- 5 kV galvanic isolation
- Supply rail reverse polarity protection
- Compatible with [STM32 Nucleo](#) development boards
- Equipped with Arduino UNO R3 connectors
- CE certified
- RoHS and China RoHS compliant
- Not FCC approved for resale

### Description

The [STEVAL-IFP046V1](#) is an industrial digital output expansion board. It provides a powerful and flexible environment for the evaluation of the driving and diagnostic capabilities of the [IPS1025H-32](#) single high-side smart power solid state relay, in a digital output module connected to 5.7 A industrial loads.

The [STEVAL-IFP046V1](#) can interface with the microcontroller on the [STM32 Nucleo](#) via 5 kV optocouplers driven by GPIO pins and Arduino R3 connectors.

The expansion board can be connected to either a [NUCLEO-F401RE](#) or a [NUCLEO-G431RB](#) development board.

It is also possible to evaluate a system composed of up to four stacked [STEVAL-IFP046V1](#) expansion boards.

As an example, a system with four [STEVAL-IFP046V1](#) expansion boards allows you to evaluate a quad channel digital output module.

Product summary	
Industrial digital output expansion board based on IPS1025H-32	<a href="#">STEVAL-IFP046V1</a>
Single high-side smart power solid state relay	<a href="#">IPS1025HQ-32</a>
Software expansion for STM32Cube driving industrial digital output based on IPS	<a href="#">X-CUBE-IPS</a>
Applications	<a href="#">Programmable Logic Controllers</a>

# 1 Schematic diagrams

Figure 1. STEVAL-IFP046V1 circuit schematic (1 of 2)

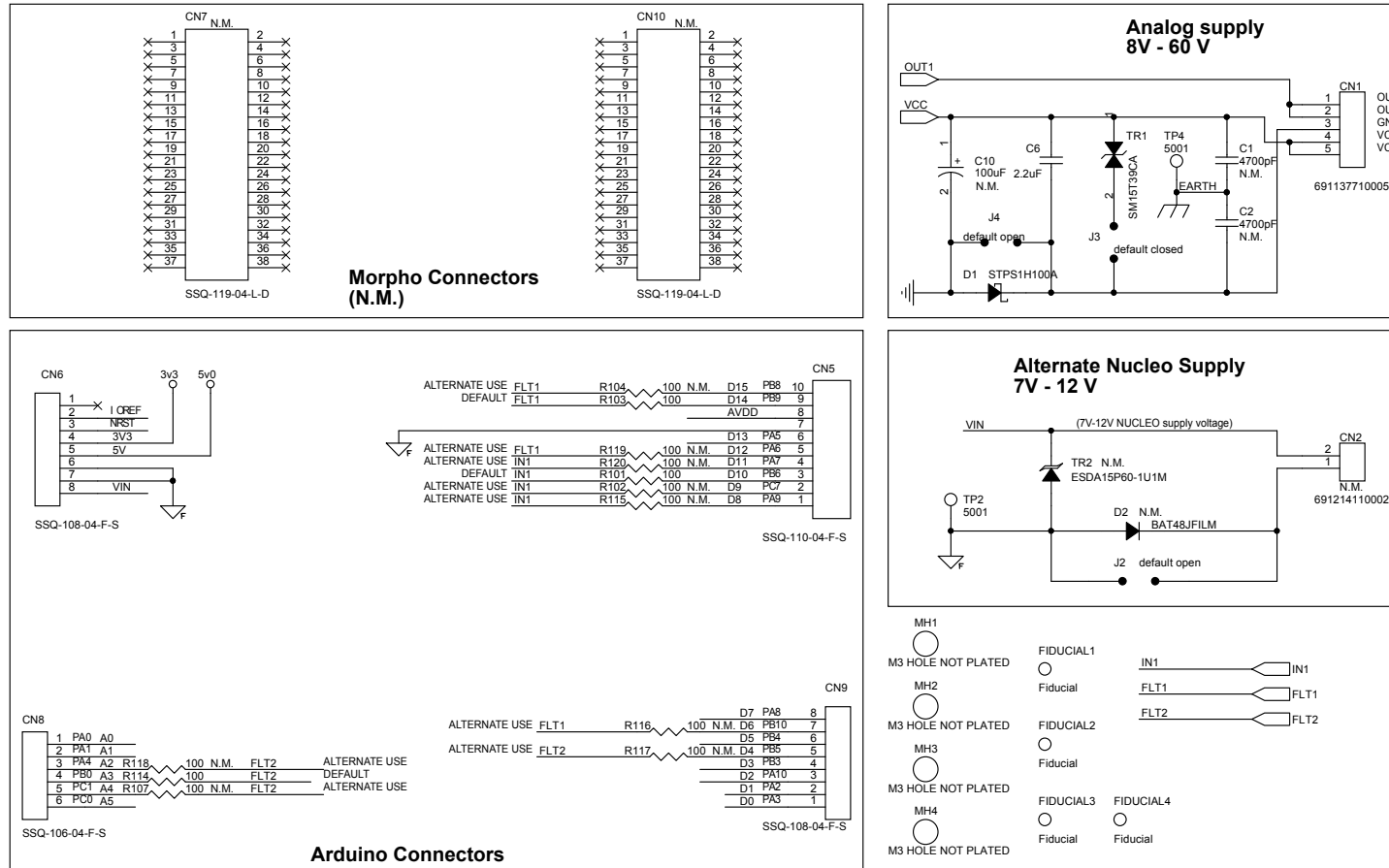
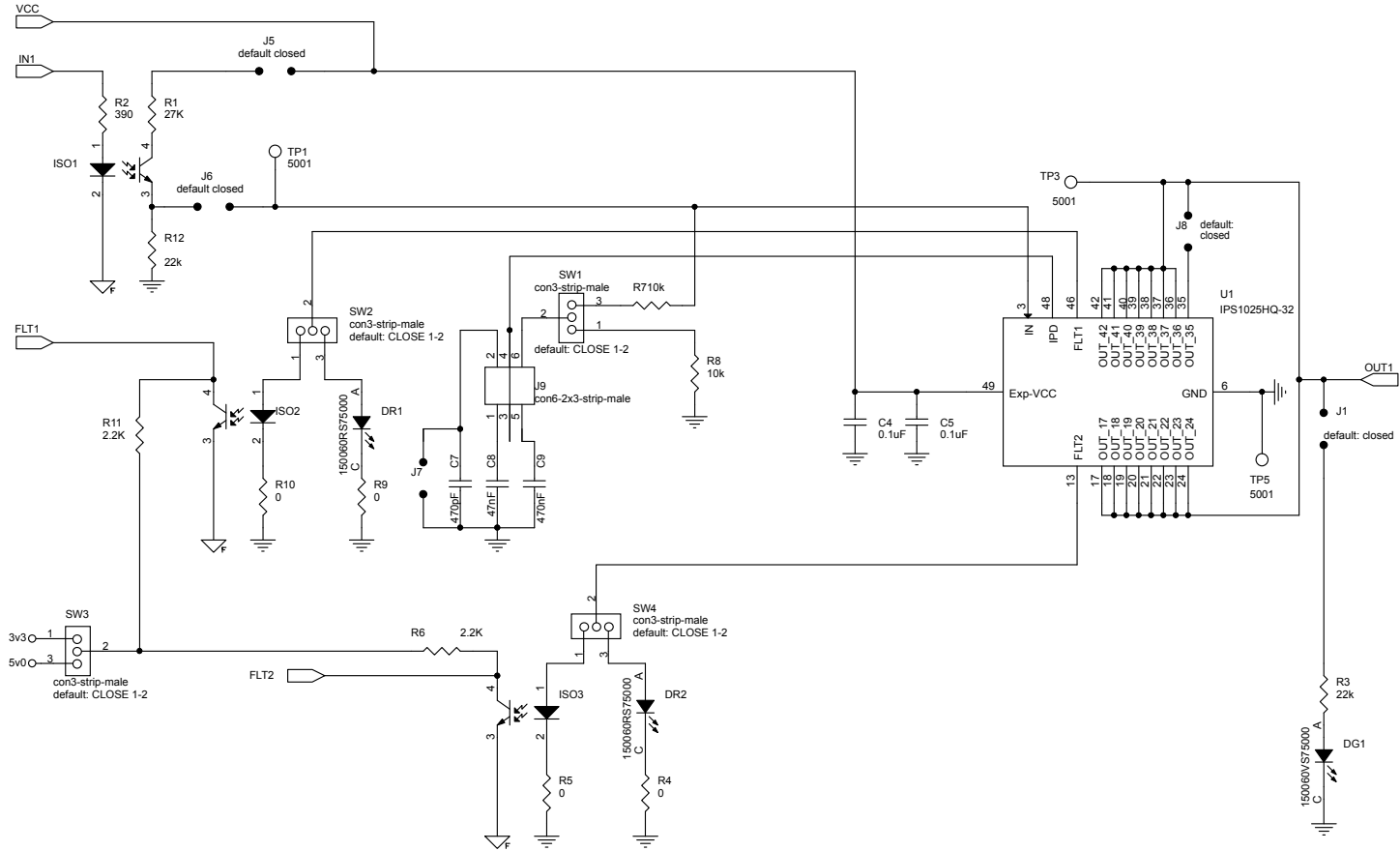

Figure 2. STEVAL-IFP046V1 circuit schematic (2 of 2)



## 2 Board versions

Table 1. STEVAL-IFP046V1 versions

PCB version	Schematic diagrams	Bill of materials
STEVAL\$IFP046V1A <sup>(1)</sup>	STEVAL\$IFP046V1A schematic diagrams	STEVAL\$IFP046V1A bill of materials

1. This code identifies the STEVAL-IFP046V1 evaluation board first version. It is printed on the board PCB.

## Revision history

**Table 2. Document revision history**

Date	Revision	Changes
29-Aug-2022	1	Initial release.