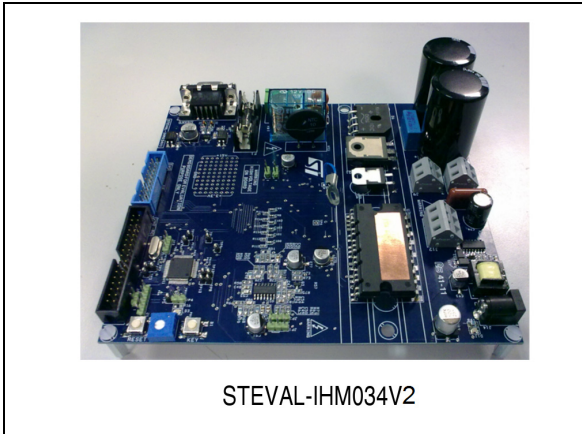


## Dual motor control and PFC evaluation board featuring the STM32F103 and STGIPS20C60

Data brief



### Features

- Nominal power 1300 W, max. power 1700 W
  - Digital PFC section:
    - Single-stage boost converter based on the STGW35HF60W (or STW38N65M5) and STTH15R06D or (STPSC1206D)
    - AC mains current sensing
    - DC bus voltage sensing
    - Hardware overcurrent protection
    - Hardware overvoltage protection
    - AC mains voltage zero crossing detection
    - Rectified AC mains voltage sensing
    - External boost inductor
  - Inverter section (motor 1 drive):
    - IGBT intelligent power module STGIPS20C60 in SDIP 25L molded package
    - 3-shunt or DC link motor current sensing
    - Hardware overcurrent protection
    - Heatsink temperature measurement
    - Overcurrent protection disabling network
  - Control section:
    - Centralized dual motor control and PFC drive, using the STM32F103RCT6
- MC connector to drive the second motor power stage (a compatible power board, such as the STEVAL-IHM021V1, STEVAL-IHM024V1, or STEVAL-IHM032V1, can be plugged here)
  - SWD programming and debugging
  - JTAG programming
  - Opto-isolated USART communication
  - Other functions:
    - User key, reset, potentiometer, user LED, NTC relay, test points
  - Power supply:
    - +15 V, +3.3 V power supply
  - RoHS compliant

# 1 Description

The STEVAL-IHM034V2 is a complete motor control kit solution for the evaluation of STMicroelectronics® wide product portfolio tailored to applications where it is necessary to drive, simultaneously, two motors in sensorless field oriented control (FOC) and perform active power factor correction (PFC) through digital control of a single-stage boost DC-DC converter.

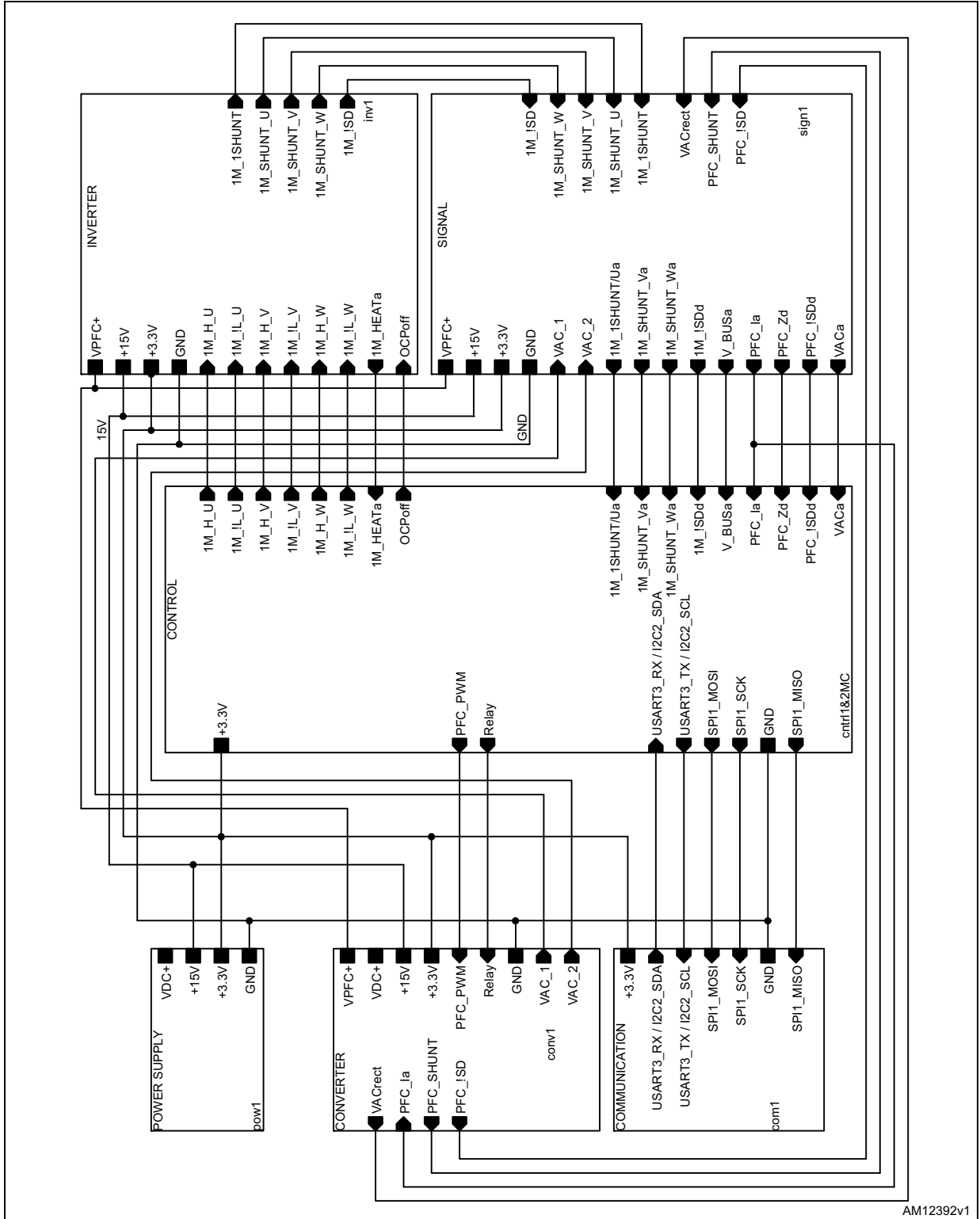
Typical applications include in-room air conditioners (RACs), where this ST solution can drive the compressor, outdoor fans and PFCs. The microcontroller unit consists of STMicroelectronics' ARM™ Cortex-M3 core-based STM32F103RC, which is capable of carrying out all of the previously-mentioned tasks simultaneously. The board is compatible with the STM32F2 series and with the ARM™ Cortex-M4 core-based STM32F4 series.

Motor 1 is powered by the onboard SLLIMM™ (small low-loss intelligent molded module) STGIPS20C60. Motor 2 can be powered by an external STMicroelectronics power stage, such as those that can be evaluated using the STEVAL-IHM021V1, STEVAL-IHM024V1, STEVAL-IHM032V1 or STEVAL-IHM035V1 evaluation boards. Simultaneously, the same microcontroller unit drives the onboard boost PFC stage designed with the STGW35HF60W ultrafast IGBT or, alternatively, for high switching frequencies the STW38N65M5 MDmesh V Power MOSFET, and STTH15R06D Turbo2 ultrafast diode or the STPSC1206D Schottky silicon carbide diode.

The STEVAL-IHM034V2 can be used together with the STM32 permanent magnet synchronous motor (PMSM) single/dual FOC software development kit (SDK) and its compatible PFC firmware plug-in.

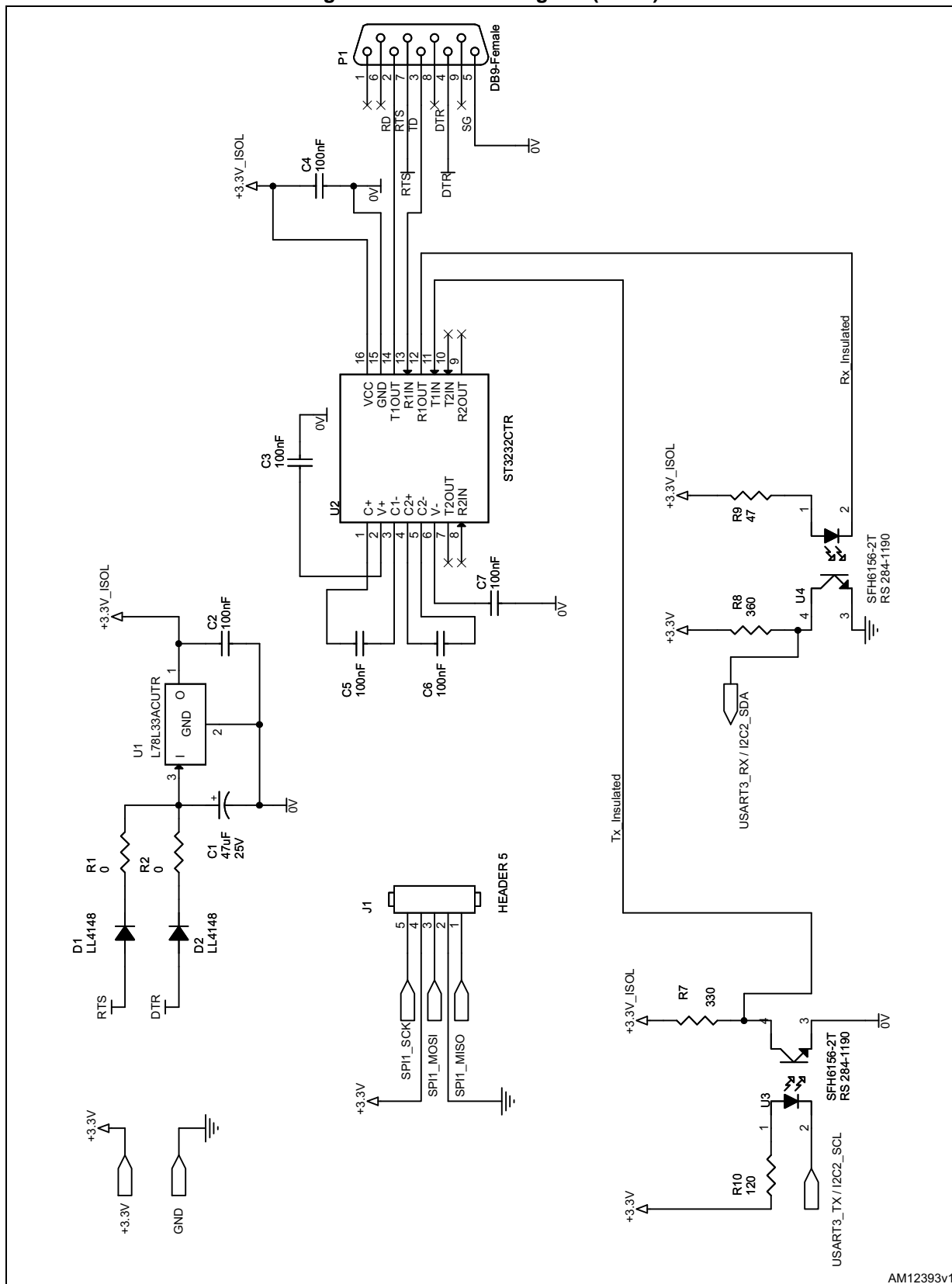
## 2 Schematic diagram

Figure 1. Schematic diagram (1 of 9)



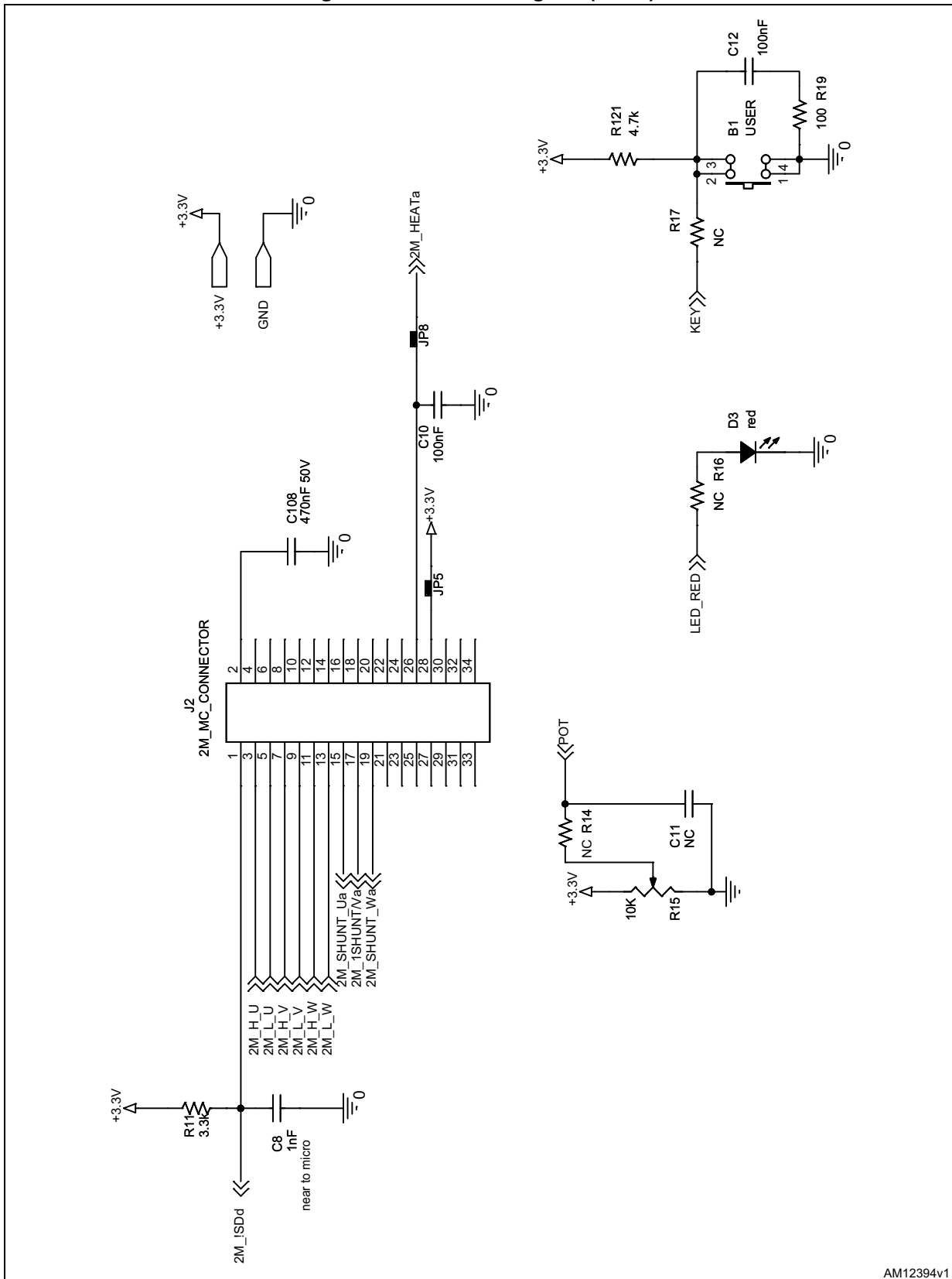
AM12392v1

Figure 2. Schematic diagram (2 of 9)



AM12393v1

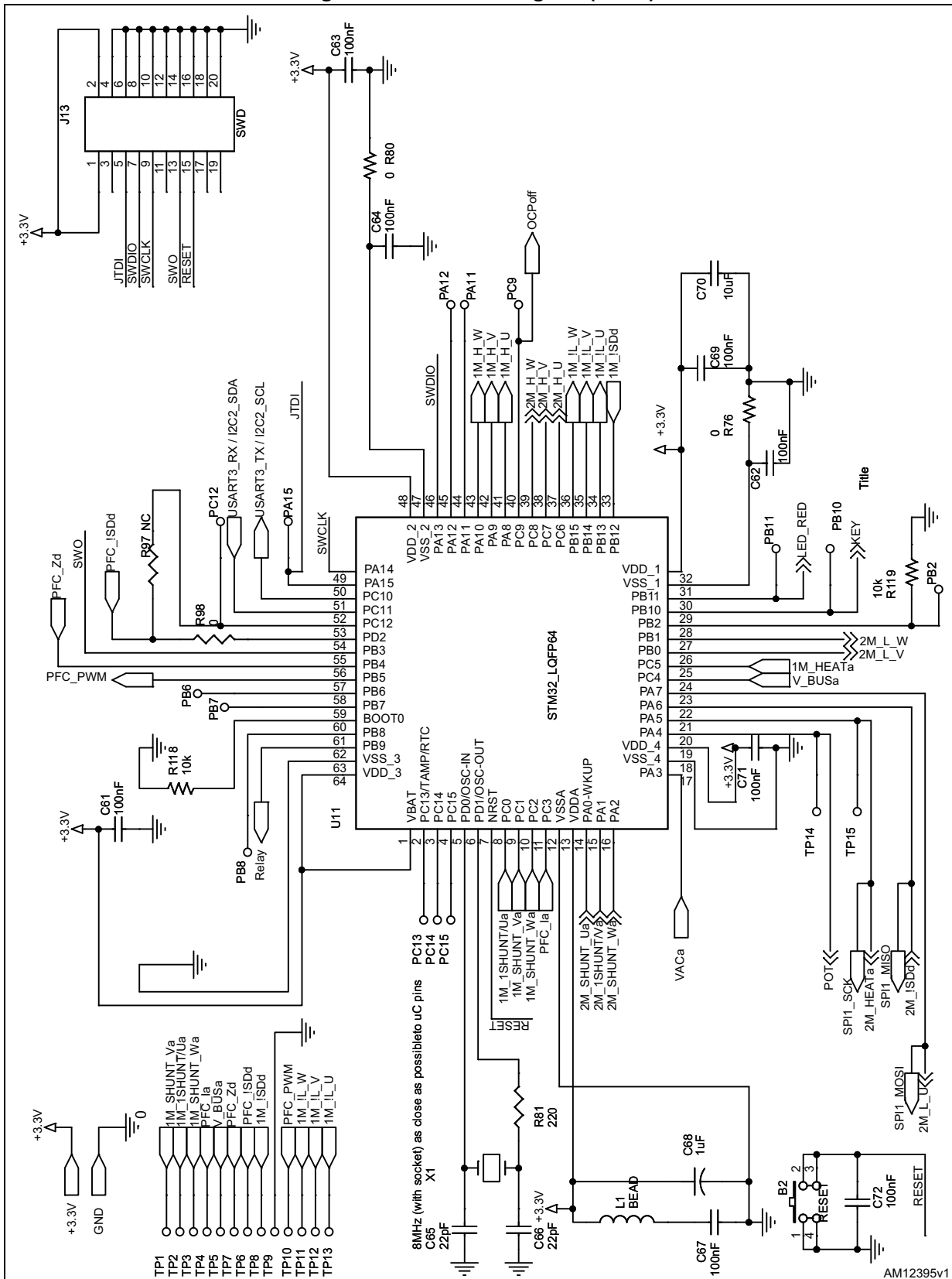
Figure 3. Schematic diagram (3 of 9)



AM12394v1



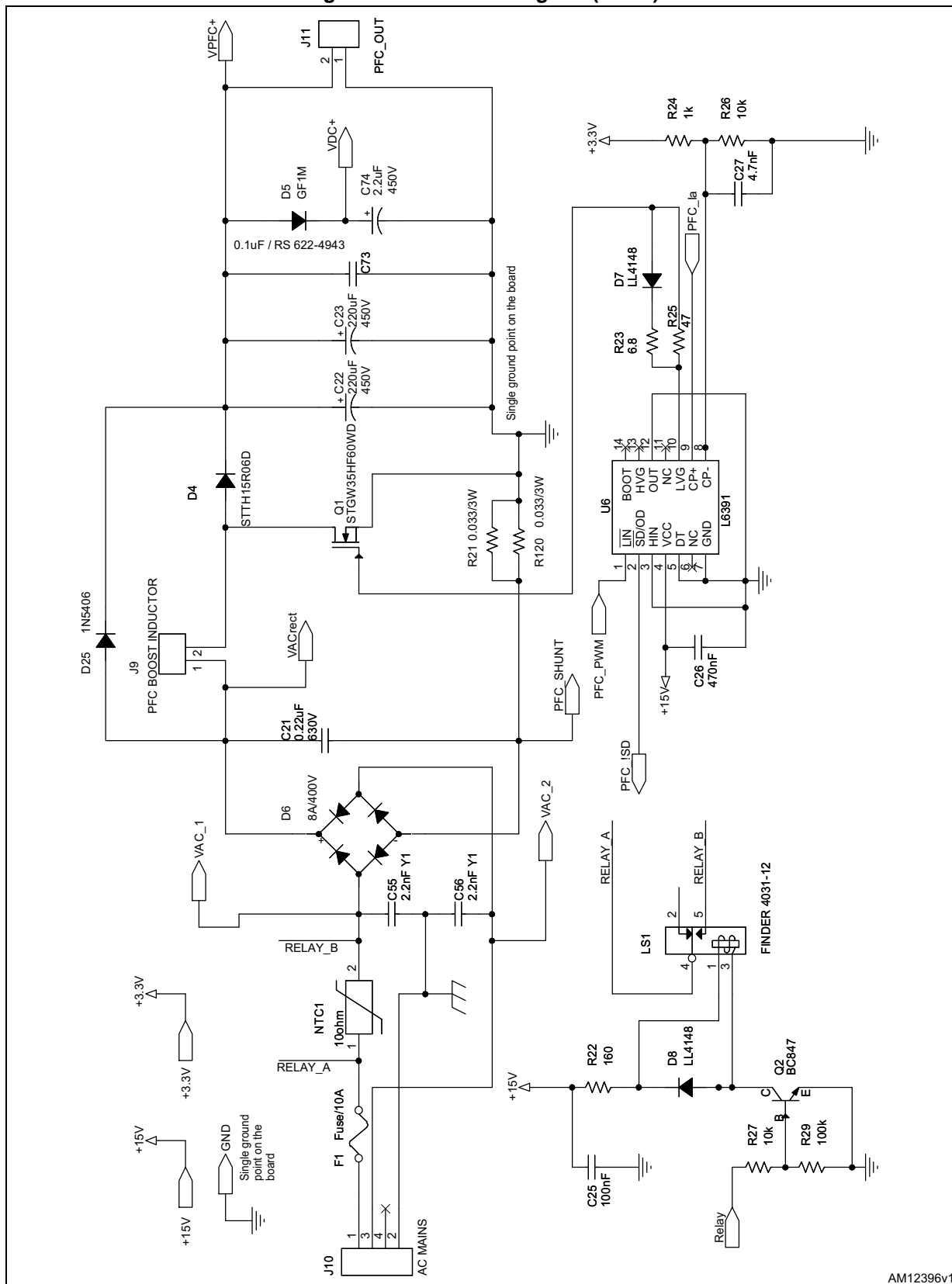
Figure 4. Schematic diagram (4 of 9)



AM12395v1

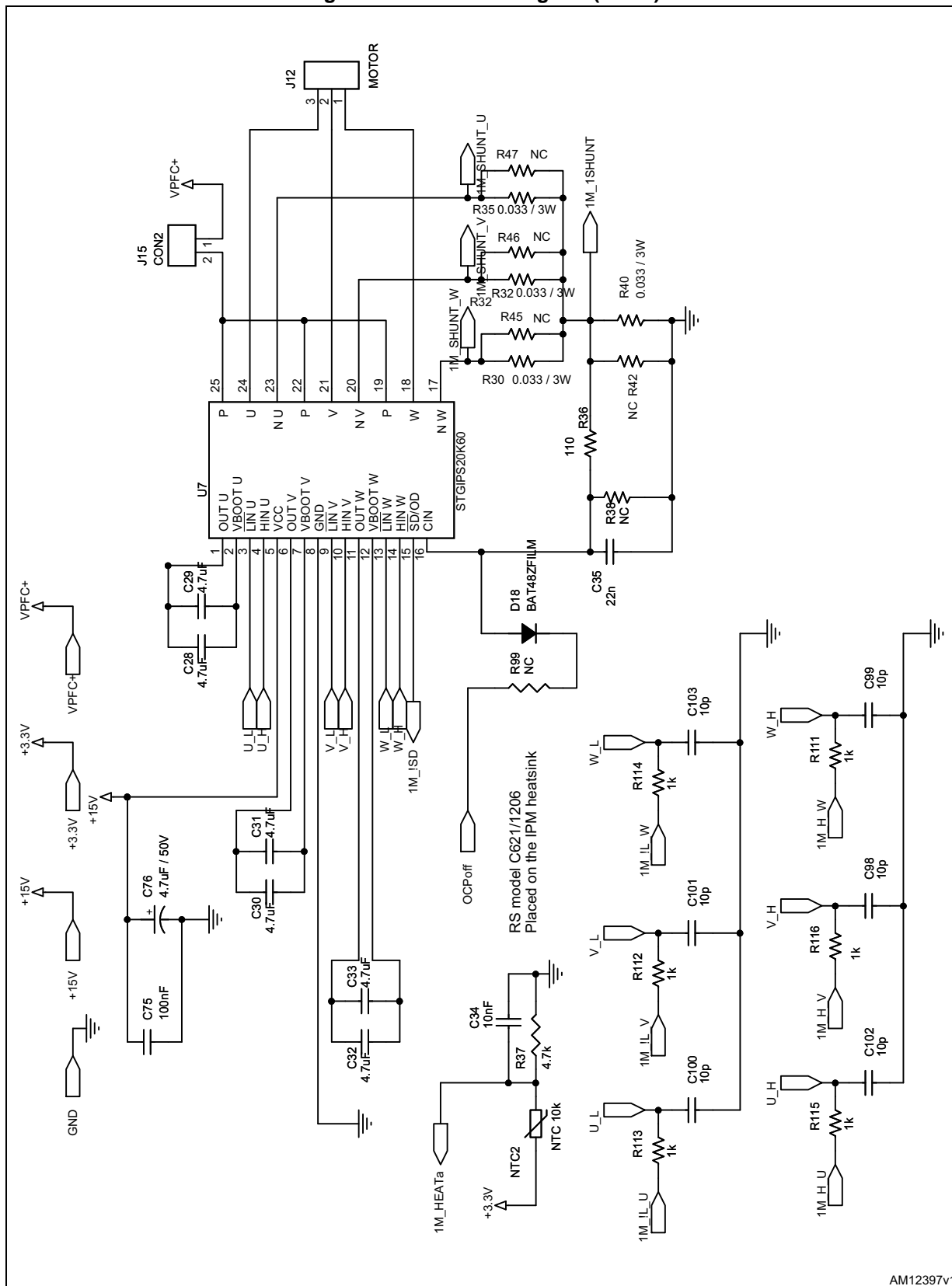


Figure 5. Schematic diagram (5 of 9)



AM12396v1

Figure 6. Schematic diagram (6 of 9)

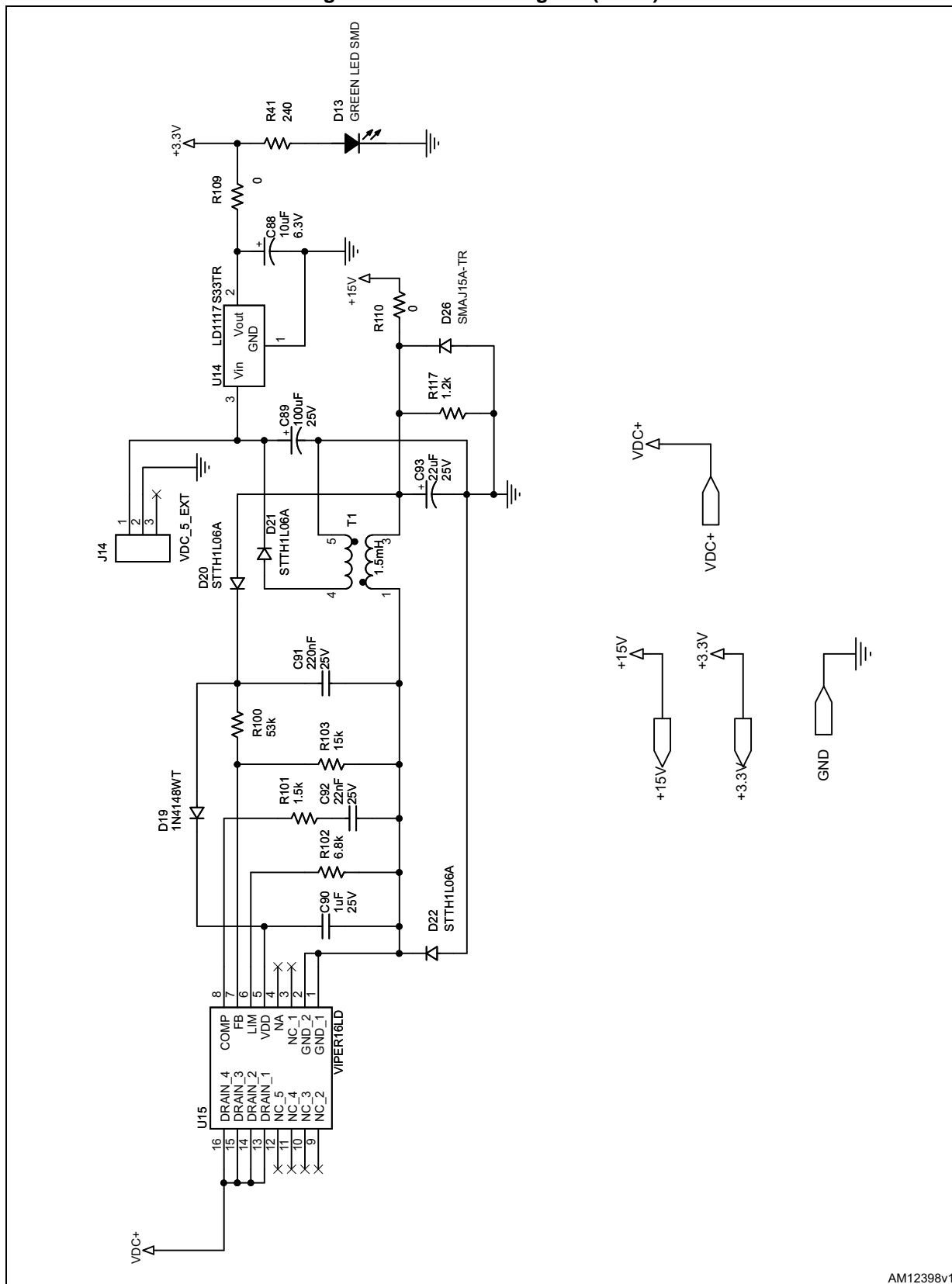


AM12397v1



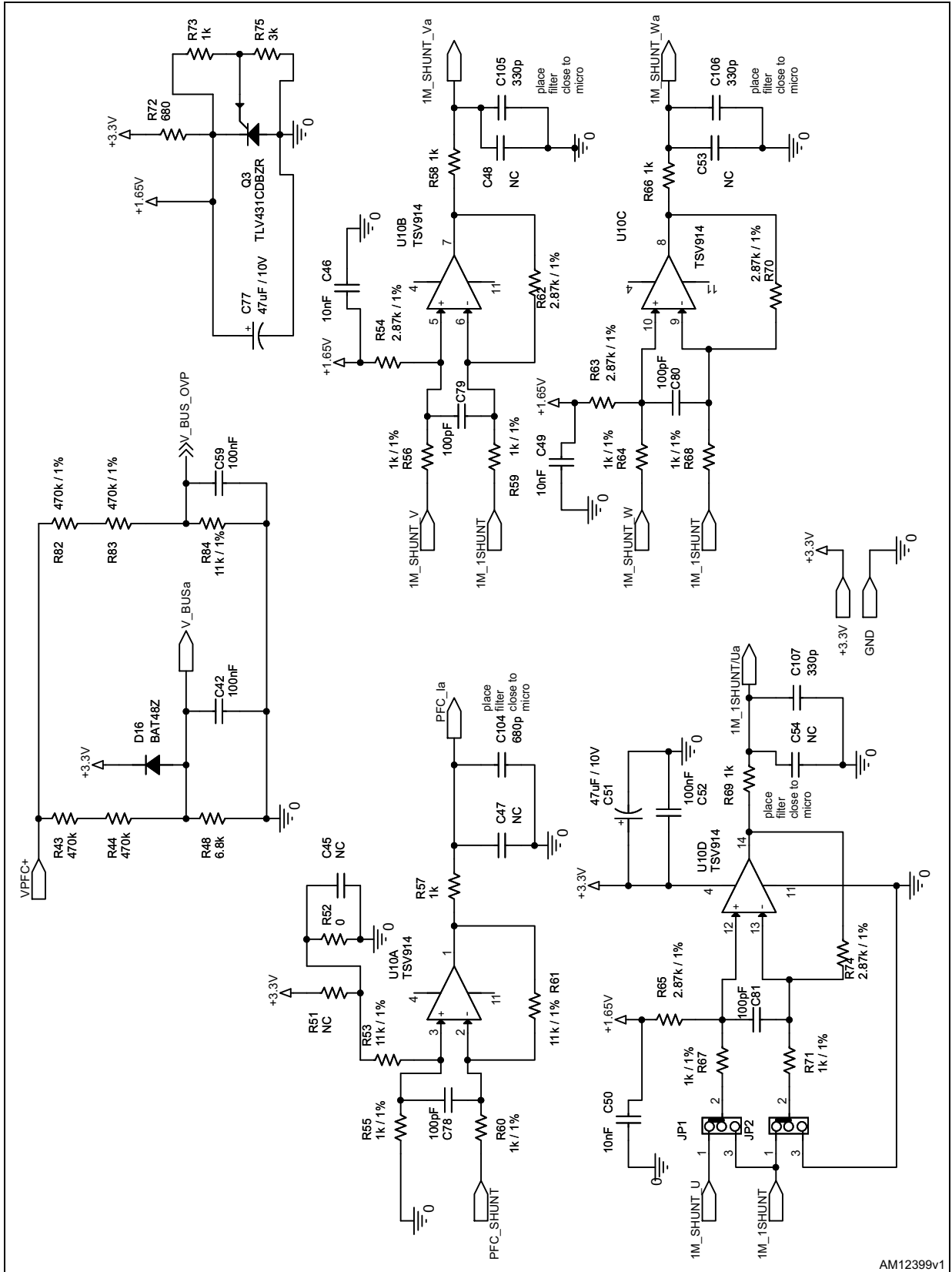


Figure 7. Schematic diagram (7 of 9)



AM12398v1

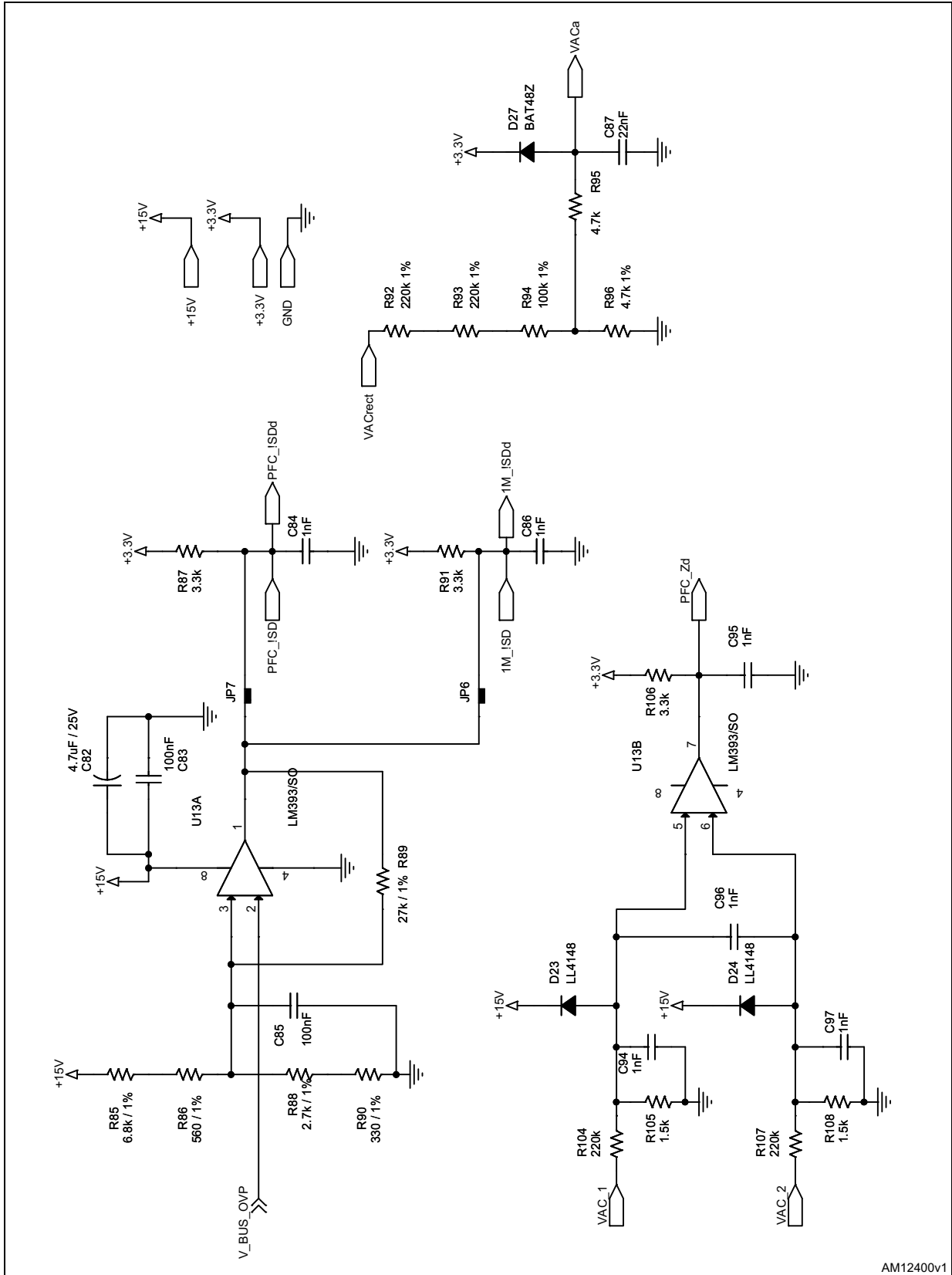
Figure 8. Schematic diagram (8 of 9)



AM12399v1



Figure 9. Schematic diagram (9 of 9)



AM12400v1



### 3 Revision history

**Table 1. Document revision history**

Date	Revision	Changes
10-Dec-2013	1	Initial release.
16-Jan-2014	2	Description has been corrected.