

**SPIRIT1 433 MHz low data rate transceiver daughterboard**

Data brief

**Description**

The STEVAL-IKR002V3D product evaluation board is based on the SPIRIT1, a very low-power RF transceiver intended for RF wireless applications in the sub 1 GHz frequency band.

**Features**

- SPIRIT1 low power sub GHz transceiver in a standalone RF module tuned for 433 MHz
- Modulation schemes: 2-FSK, GFSK, MSK, GMSK, OOK, and ASK
- Suitable for wireless M-BUS applications
- Programmable air data rate: from 1 to 500 kbps
- Very low power consumption: 9.2mA RX and 19.5 mA TX at +11 dBm
- Excellent receiver sensitivity (down to -120 dBm)
- Low duty cycle RX/TX operation mode
- Automatic acknowledgment, retransmission, and timeout protocol engine
- AES 128-bit encryption co-processor
- SPI interface for microcontroller
- RoHS compliant

# 1 Schematic diagram

Figure 1. STEVAL-IKR002V3D circuit schematic

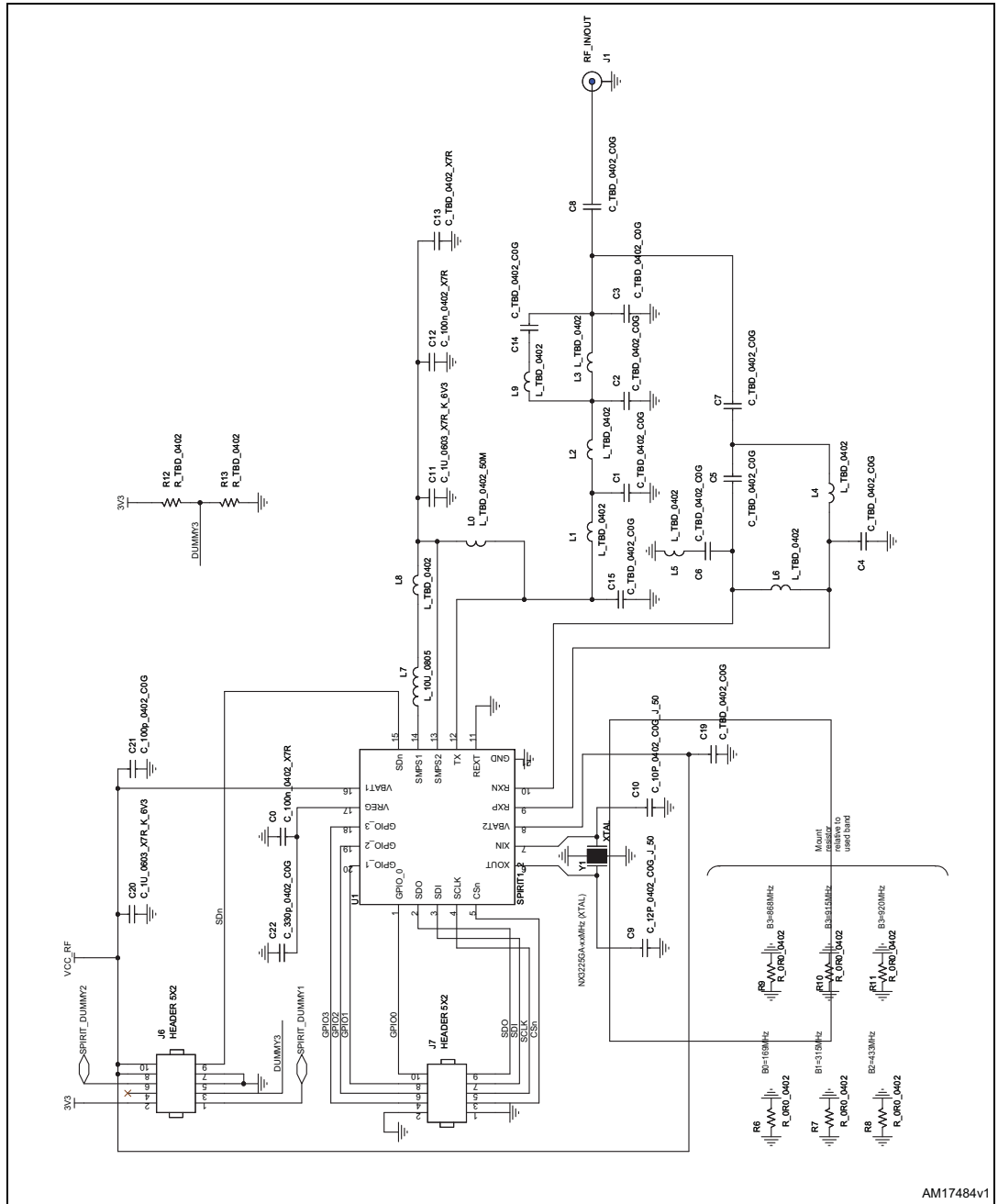

AM17484v1



## 2 Revision history

Table 1. Document revision history

Date	Revision	Changes
07-Aug-2014	1	Initial release.