**SPIRIT1 169 MHz low data rate transceiver daughterboard
with range extender**

Data brief

**Description**

The STEVAL-IKR002V7D product evaluation board is based on the SPIRIT1, a very low-power RF transceiver intended for RF wireless applications in the sub 1 GHz frequency band.

The STEVAL-IKR002V7D also features an on-board external front-end module from Skyworks® (SKY66100-11), which can reach a maximum output power of +27 dBm (500 mW).

Features

- SPIRIT1 low power sub GHz transceiver in a standalone RF module tuned for 169 MHz, with external Skyworks® front-end module (SKY66100-11)
- Modulation schemes: 2-FSK, GFSK, MSK, GMSK, OOK, and ASK
- Programmable air data rate: from 1 to 500 kbps
- Maximum output power: +27 dBm
- Excellent receiver sensitivity (-123 dBm)
- Suitable for wireless M-BUS applications
- Meets the tight narrow-band system requirements
- Low duty cycle RX/TX operation mode
- Automatic acknowledgment, retransmission, and timeout protocol engine
- AES 128-bit encryption co-processor
- SPI interface for microcontroller
- RoHS compliant

1 Schematic diagram

Figure 1. STEVAL-IKR002V7D circuit schematic (1 of 2)

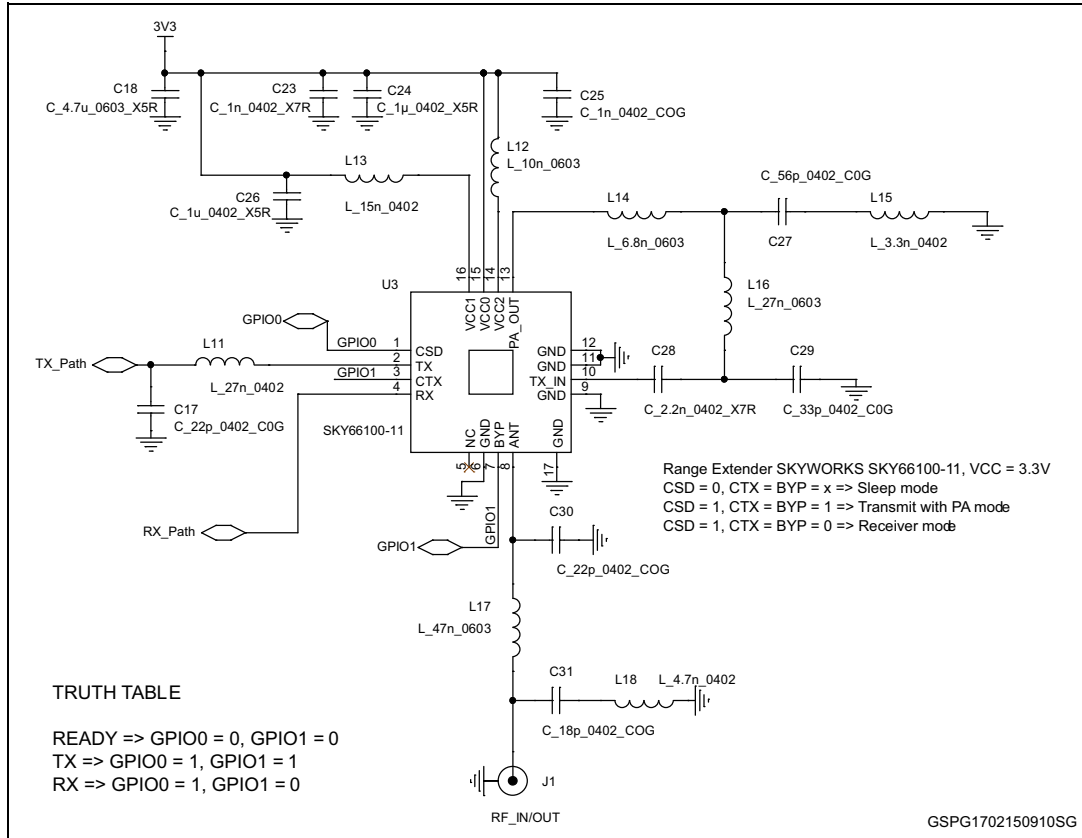
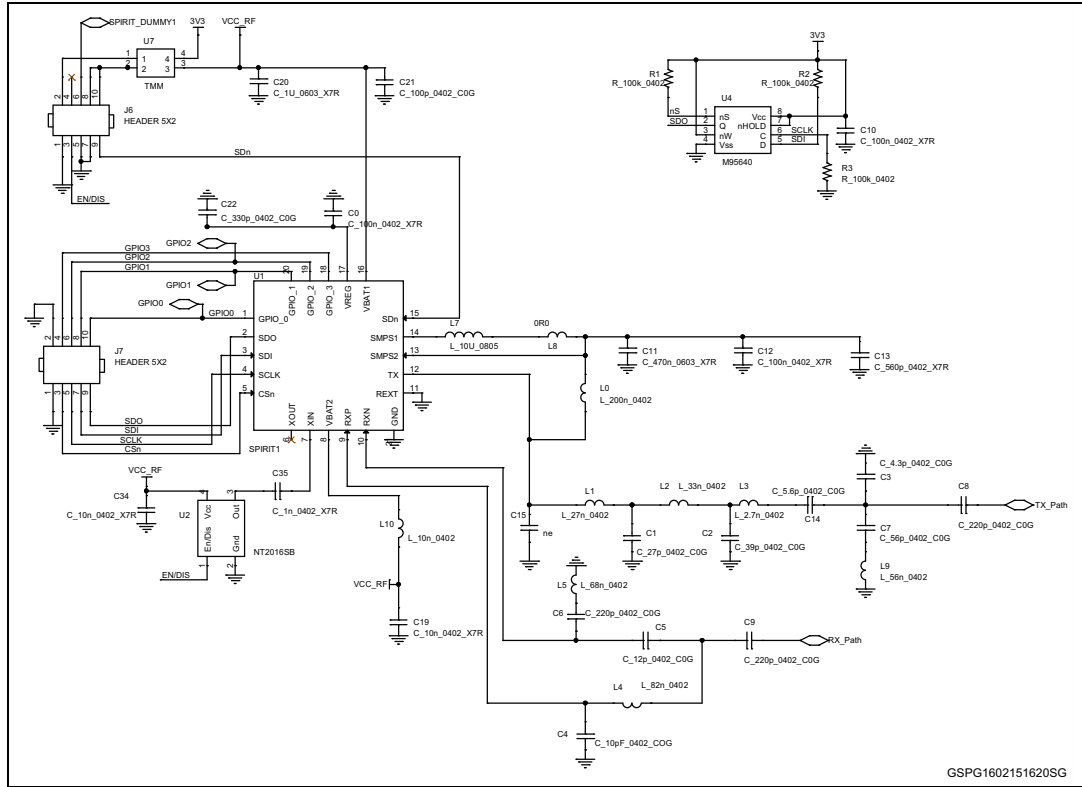

Figure 2. STEVAL-IKR002V7D circuit schematic (2 of 2)



2 Revision history

Table 1. Document revision history

Date	Revision	Changes
07-Aug-2014	1	Initial release
19-Feb-2015	2	Updated <i>Figure 1 on page 2</i> and <i>Figure 2 on page 3</i>