



STEVAL-ILL020V1

LCD panels backlight demonstration board based on the LED7706

Data brief

Features

- Features boost section
 - 4.5 V to 36 V input voltage range
 - internal power MOSFET
 - internal +5 V LDO for device supply
 - up to 36 V output voltage
 - constant frequency peak current-mode control
 - 200 kHz to 1 MHz adjustable switching frequency
 - external sync for multi-device application
 - pulse-skip power saving mode at light load
 - programmable soft-start
 - programmable OVP protection
 - single ceramic output capacitor
 - non-latched thermal shutdown
- Features backlight driver section
 - six rows with 30 mA maximum current capability (adjustable)
 - pp to 10 white LEDs per row
 - rows disable option
 - less than 500 ns minimum dimming time (1% minimum dimming duty-cycle at 20 kHz dimming frequency)
 - $\pm 2.0\%$ current matching between rows
 - LED failure (open and short circuit) detection
- RoHS compliant

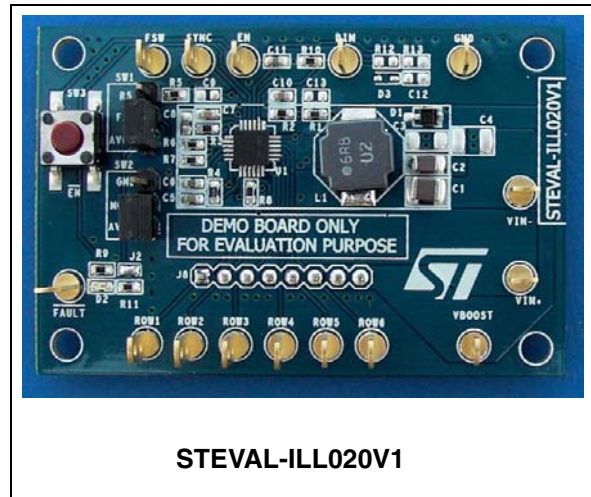

The generators can be externally programmed to sink up to 30 mA and can be dimmed via a PWM signal (1% dimming duty cycle at 20 kHz can be managed).

The device allows to detect and manage the open and shorted LED faults and to let unused rows floating.

Basic protections (output overvoltage, internal MOSFET overcurrent and thermal shutdown) are provided.

Description

This demonstration board is based on the LED7706 and implements a high efficiency monolithic boost converter and six controlled current generators (rows) specifically designed to supply LEDs arrays used in the backlight of LCD panels.

The device can manage an output voltage up to 36 V (i.e. ten white-LEDs per row).

1 Circuit schematic and PCB layout

Figure 1. Schematic diagram

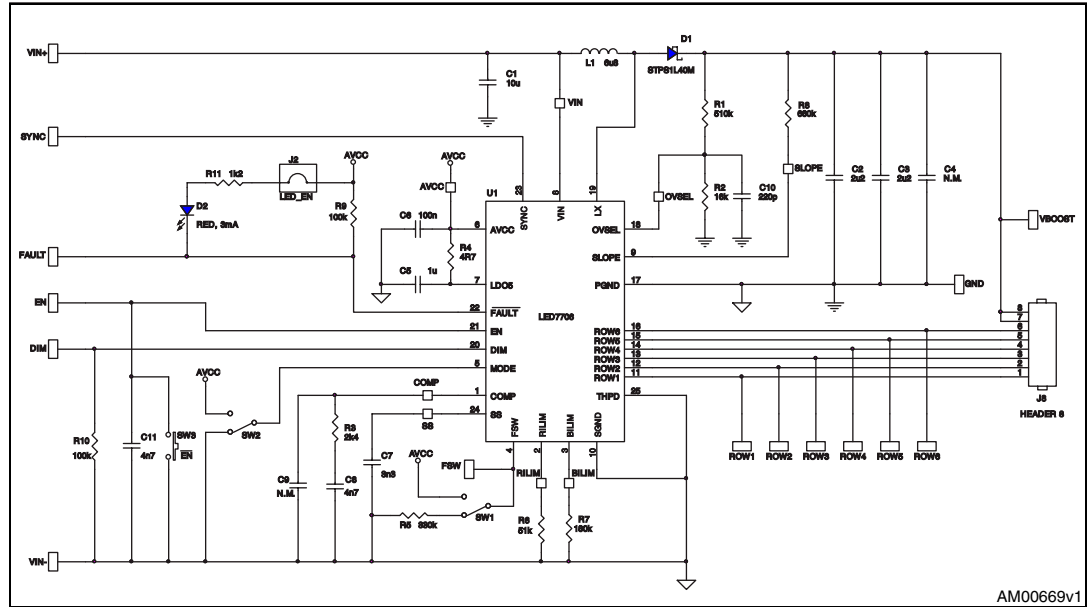

Figure 2. Top side component placement

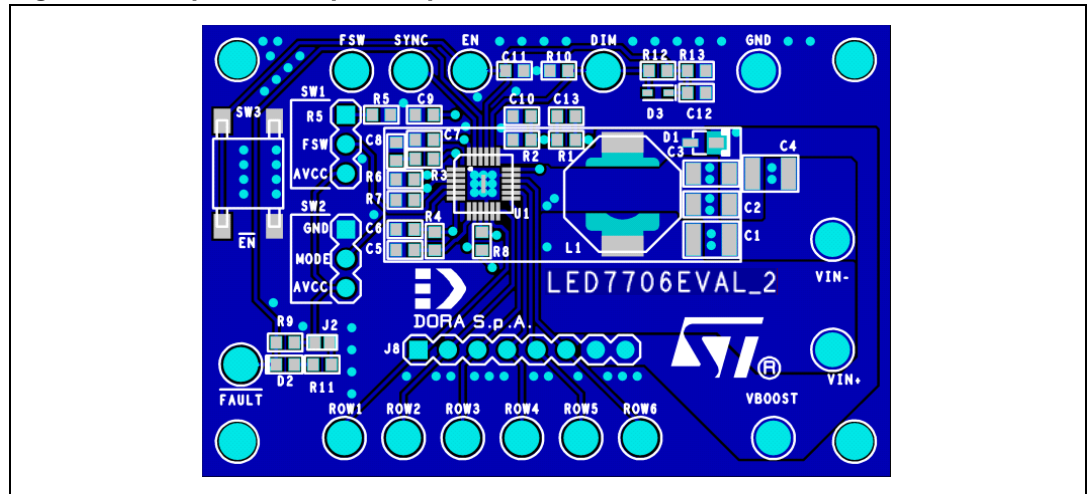
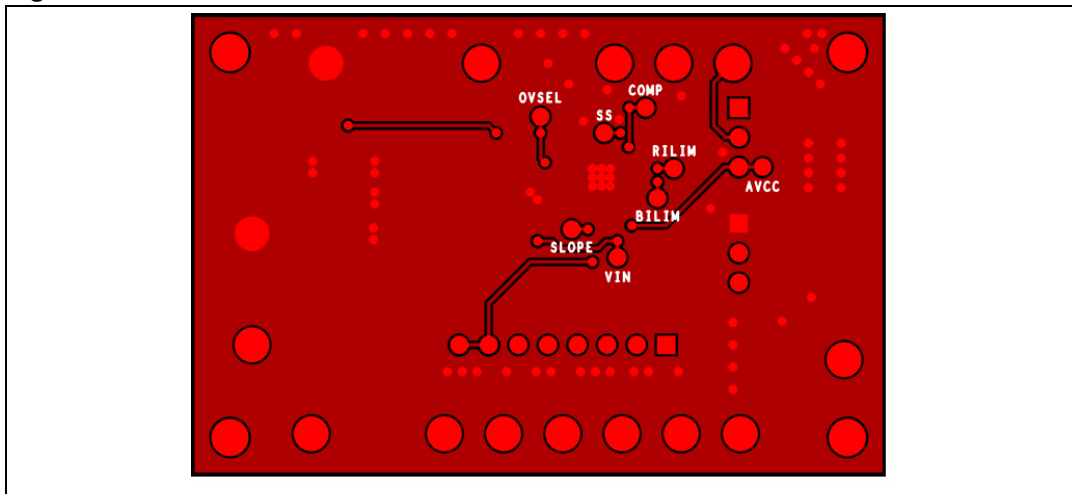

Figure 3. Bottom side



2 Revision history

Table 1. Document revision history

Date	Revision	Changes
06-May-2009	1	Initial release.