



STEVAL-ILL021V1

LCD panels backlight demonstration board based on the LED7707

Data brief

Features

- Features boost section
 - 4.5 V to 36 V input voltage range
 - internal power MOSFET
 - internal +5 V LDO for device supply
 - up to 36 V output voltage
 - constant frequency peak current-mode control
 - 250 kHz to 1 MHz adjustable switching frequency
 - external sync for multi-device application
 - pulse-skip power saving mode at light load
 - programmable soft-start
 - programmable OVP protection
 - single ceramic output capacitor
 - non-latched thermal shutdown
- Features backlight driver section
 - six rows with 85 mA maximum current capability (adjustable)
 - up to 10 white LEDs per row
 - rows disable option
 - less than 10 μ s minimum dimming time
 - $\pm 2.0\%$ current matching between rows
 - LED failure (open and short circuit) detection
- RoHS compliant

Description

This demonstration boards is based on the LED7707 and implements a high efficiency monolithic boost converter and six controlled current generators (rows) specifically designed to supply LEDs arrays used in the backlight of LCD panels.

The device can manage an output voltage up to 36 V (i.e. ten white-LEDs per row).



The generators can be externally programmed to sink up to 85 mA and can be dimmed via a PWM signal (1% of minimum dimming duty cycle at 1kHz can be managed).

The device allows to detect and manage the open and shorted LED faults and to let unused rows floating.

Basic protections (output overvoltage, internal MOSFET overcurrent and thermal shutdown) are provided.

1 Circuit schematic and PCB layout

Figure 1. Schematic diagram

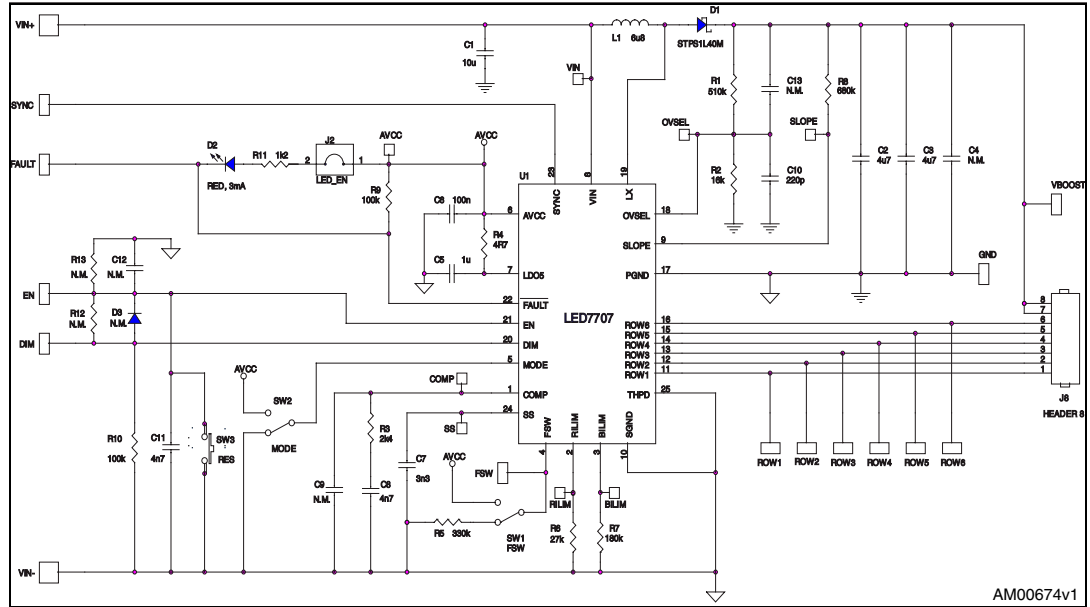

Figure 2. Top side component placement

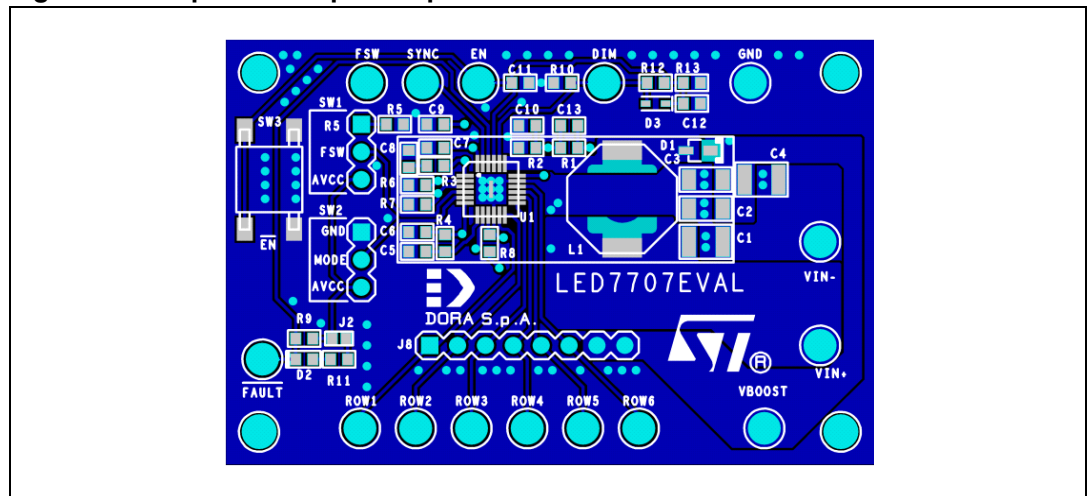
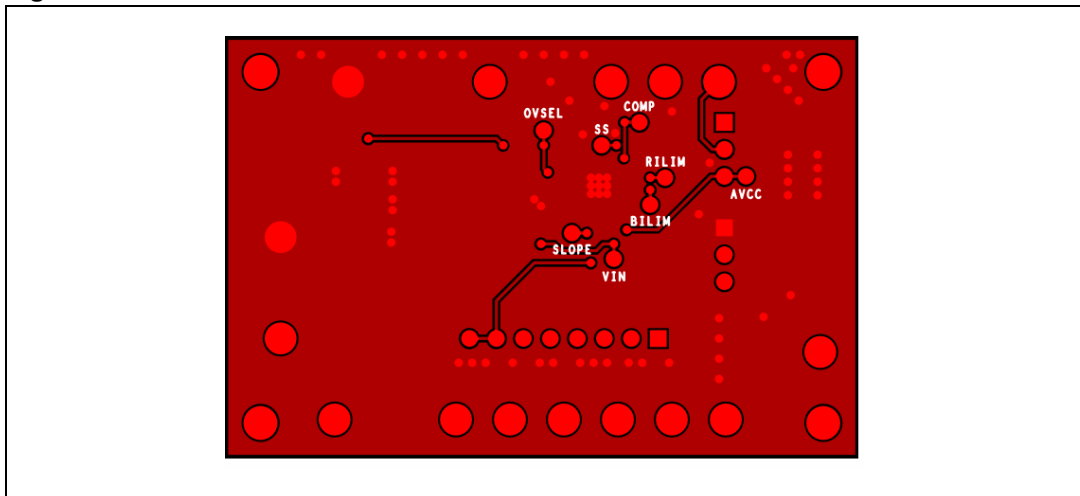

Figure 3. Bottom side



2 Revision history

Table 1. Document revision history

Date	Revision	Changes
06-May-2009	1	Initial release.