



Multi-channel LED driver with integrated boost controller for medium, large LCD panel backlight based on LED7708 and STM32F103C6T6A

Data brief

Features

- Wide DC input voltage: 10 V to 28 V
- Integrated boost converter with adaptive output voltage for minimum power dissipation
- Up to 92% boost converter efficiency
- 16 channels with up to 85 mA/ch current capability and independent PWM brightness control
- Up to 15 white LEDs per channel
- On-board STM32 microcontroller for total device control through 4-wire serial interface
- Embedded open-channel and LED short-circuit faults management
- USB connection for device control through dedicated PC-GUI
- Expansion connector to support slave devices (daughterboard)
- RoHS compliant

Description

The purpose of the STEVAL-ILL035V1 demonstration board is to provide an application example of a compact LED backlight driver using the LED7708 device.

The board is equipped with a 16-channel LED driver with integrated boost controller (the LED7708), power section components, and an STM32 microcontroller to easily control all the features via a USB connection.

The output voltage required by the LED strings connected to the output channels is derived from a single input rail and continuously adjusted to minimize the voltage drop (and power dissipation) across them, despite an independent PWM duty cycle for each one. The brightness of each LED string is digitally controlled with 12- or 16-bit dimming resolution.

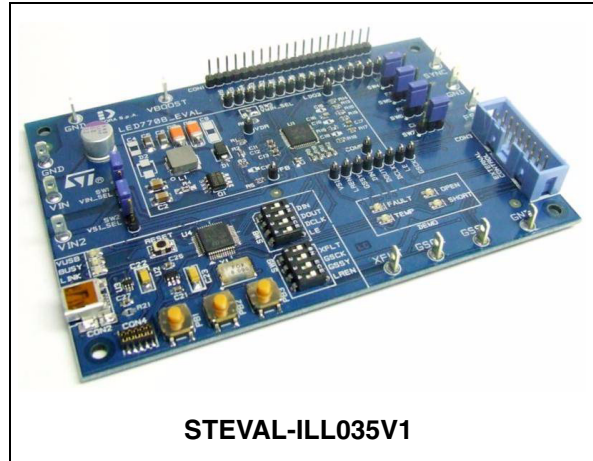

Embedded, programmable fault detection and management circuitry can be set to automatically disconnect faulty channels without the need for intervention by the host controller.

The board has been designed as a demonstration of a solution for medium/large LCD panel backlight drivers, but is suitable for any application involving several LEDs assembled in strings (e.g. advertisement panels, signs, gaming, etc.).

1 Schematic diagrams

Figure 1. LED driver

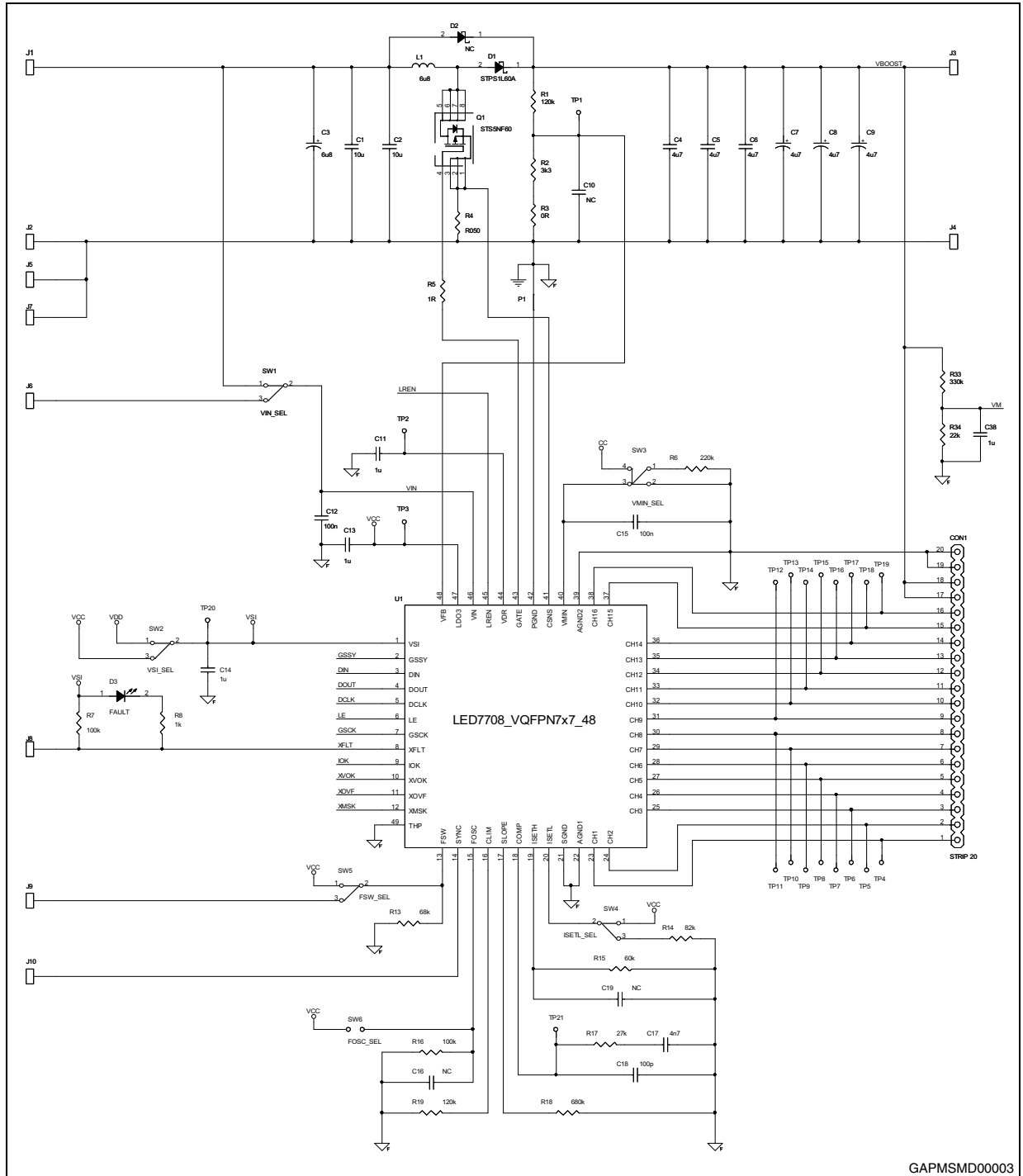
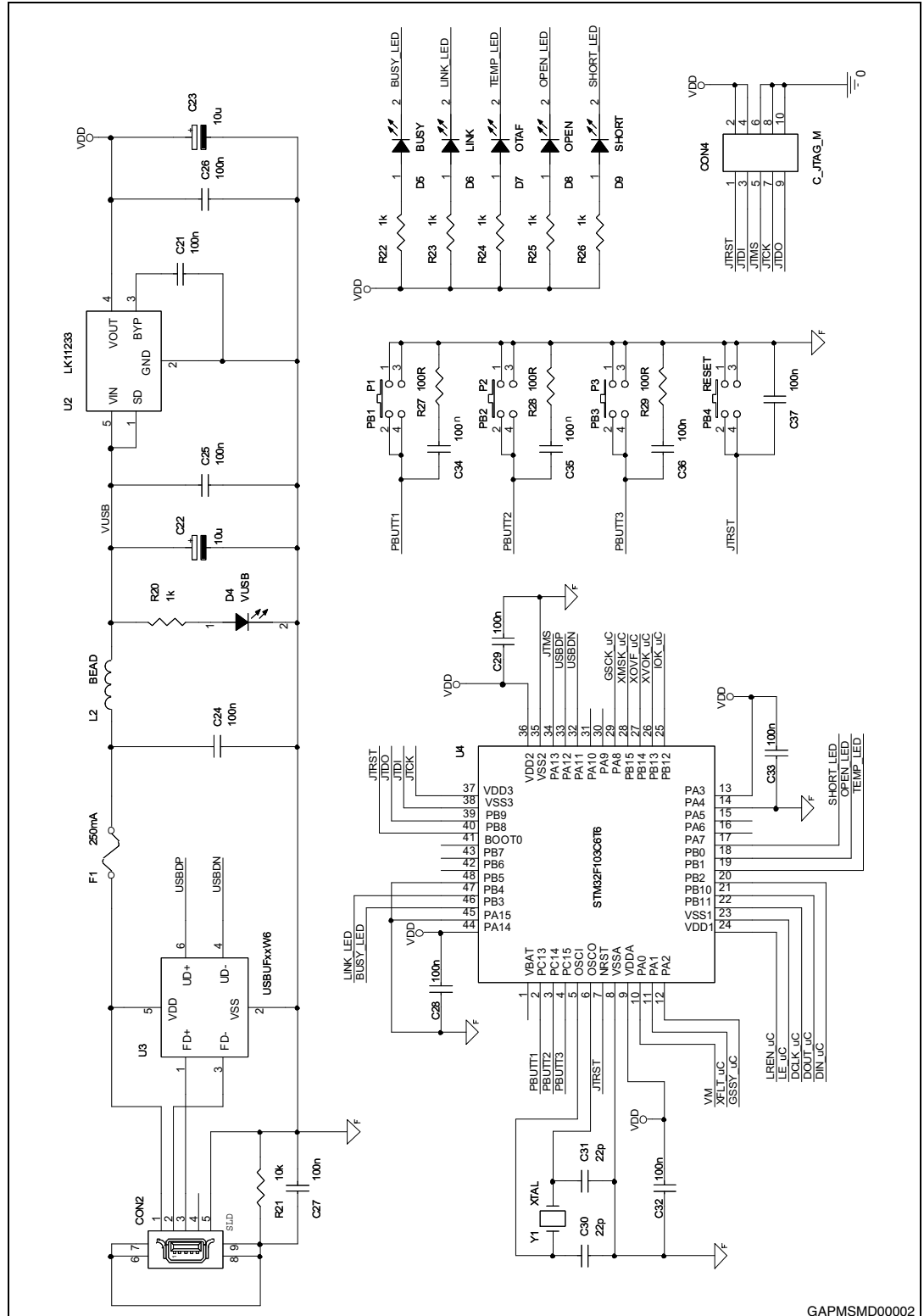
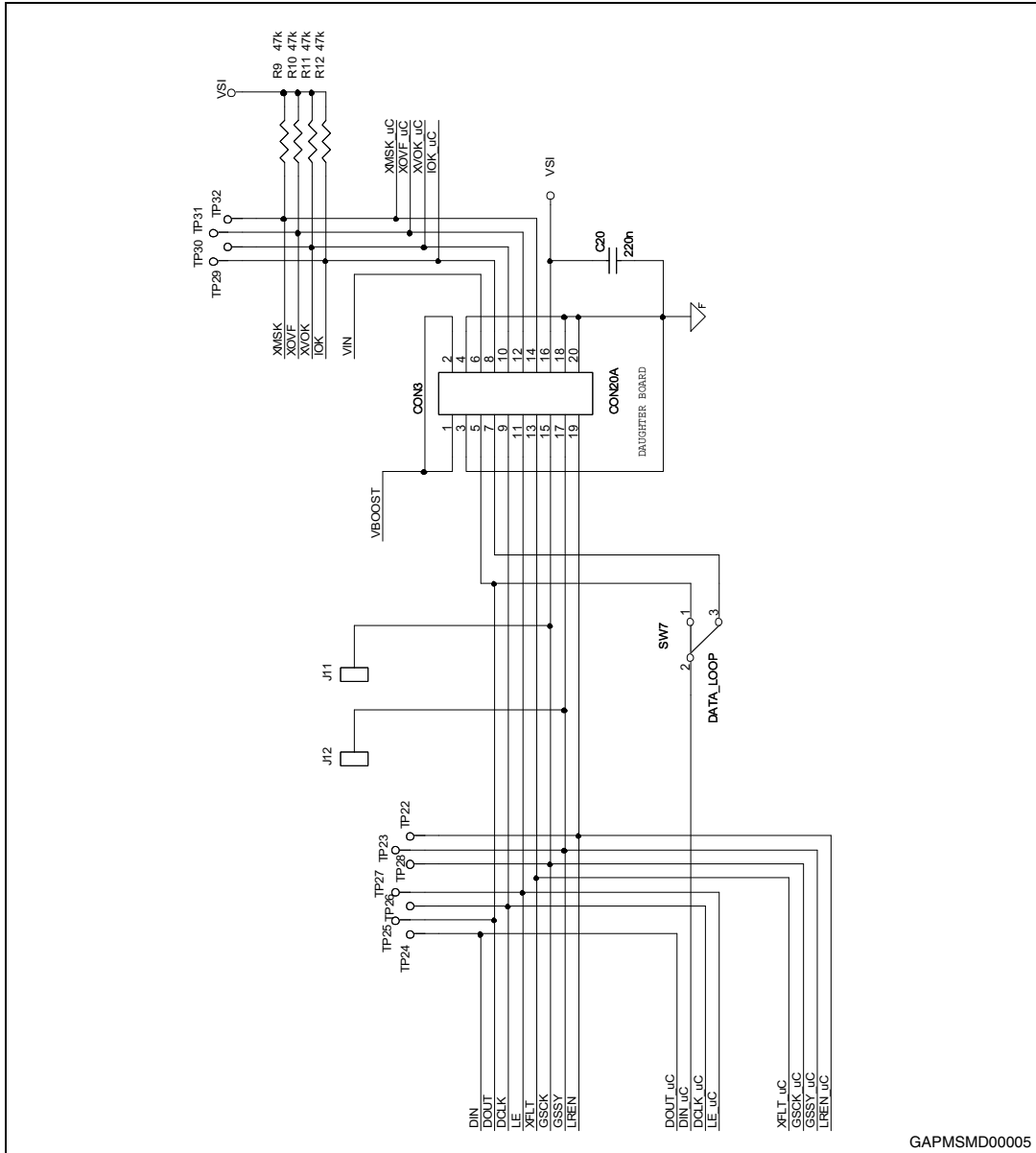

Figure 2. STM32 controller



GAPMSMD00002

Figure 3. Connector



GAPMSMD00005

Figure 4. JTAG adapter (separated PCB)

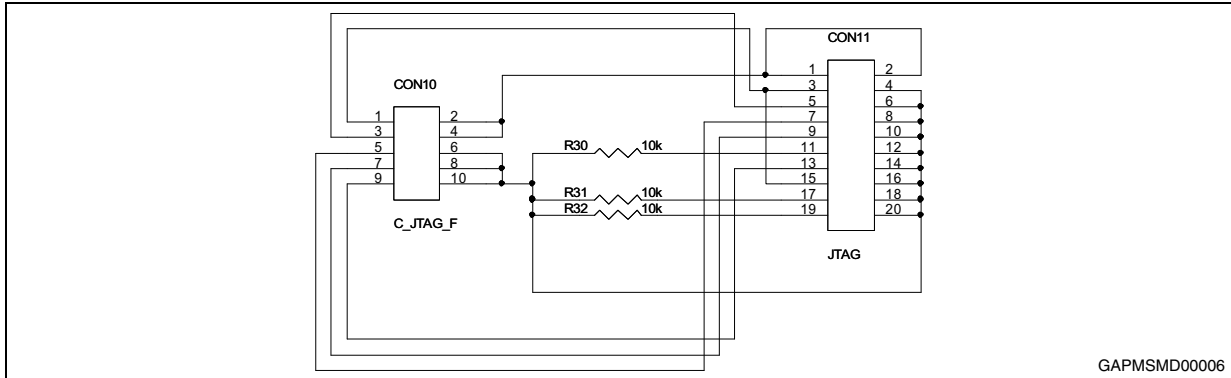

GAPMSMD00006

2 Revision history

Table 1. Document revision history

Date	Revision	Changes
04-Jun-2012	1	Initial release.