



STEVAL-ILL037V1

Demonstration board for the HVLED805 IC for LED power supply

Data brief

Features

- Input voltage: 90 Vac - 265 Vac
- Input frequency: 50 Hz - 60 Hz
- Output power: 3.2 W
- Expected efficiency: 85%
- Output voltage: ~16 Vdc (from 3 to 5 LEDs)
- Output current: 200 mA
- For E26/E27/GU10 LED lamps
- RoHS compliant

Description

The STEVAL-ILL037V1 demonstration board implements a 3.2 W (16 V / 0.2 A) wide range LED driver to support from 3 to 5 LEDs for LED lamps (e.g. E27 and GU10).

The HVLED805 is an offline all-primary sensing switching regulator, specific to offline LED drivers, based on quasi-resonant ZVS (zero voltage switching at switch turn-on) flyback topology, due to its simplicity and low cost.

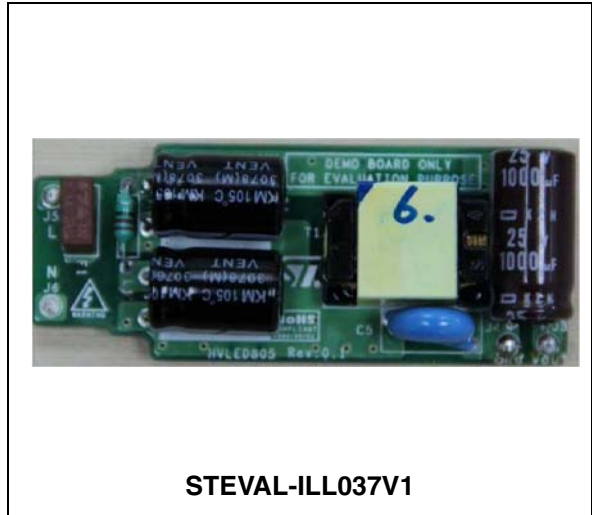

1 Circuit schematic

Figure 1. Circuit schematic

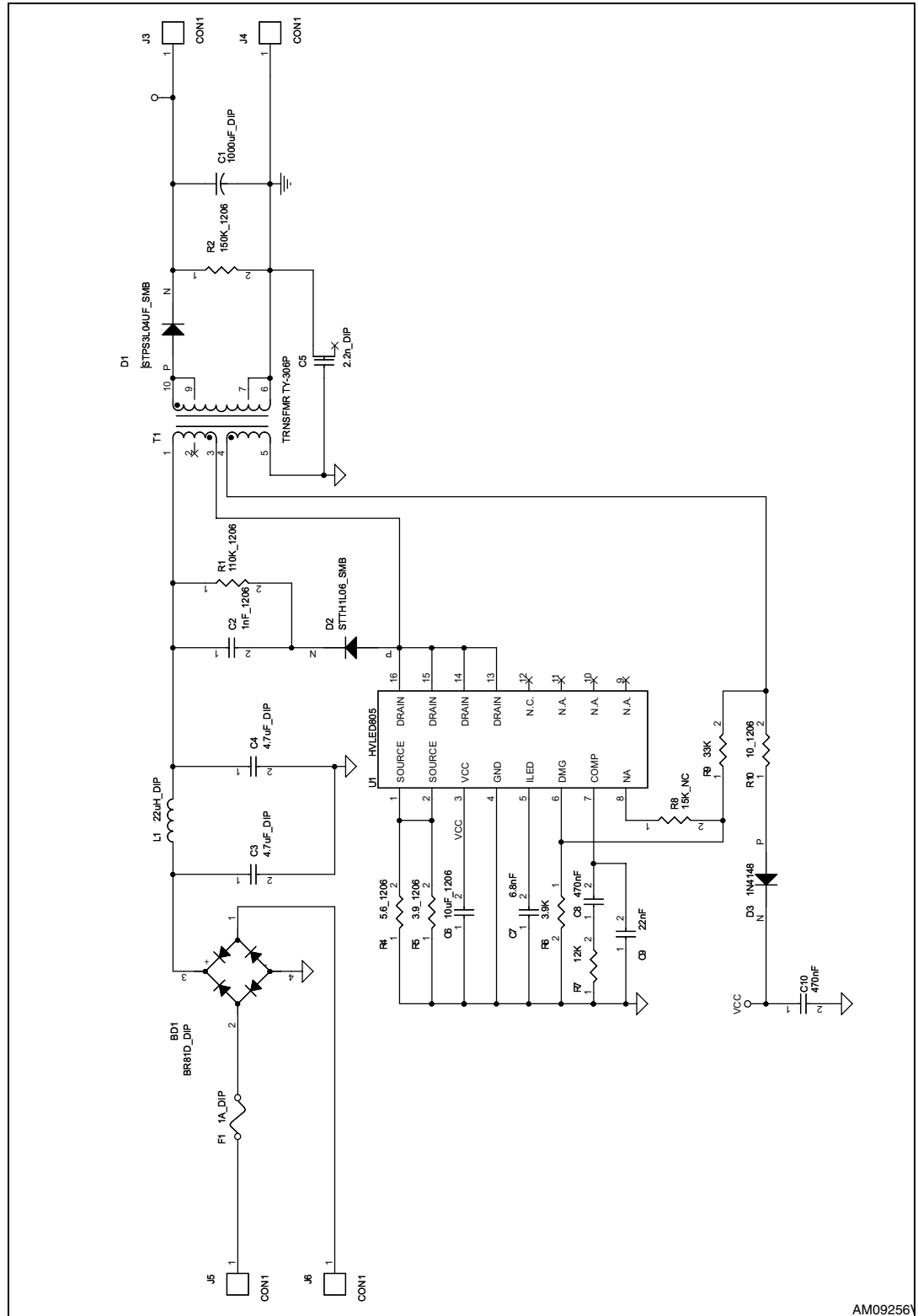

AM09256

2 Revision history

Table 1. Document revision history

Date	Revision	Changes
13-Apr-2011	1	Initial release.