



STEVAL-ILL039V2

Step-up current controller for 4 LEDs based on the STLDC08 driver

Data brief

Features

- Input voltage: 0.8 V to 3.6 V
- Output: 4 LEDs at $I_{LED} = 300$ mA
- Dimming mode with external PWM signal
- RoHS compliant

Description

The purpose of the STEVAL-ILL039V2 demonstration board is to provide an example for applications of an LED driver using the step-up controller STLDC08.

The STLDC08 is designed for handheld equipment supplied by AA or AAA batteries and provides a precise constant current starting from a variable input voltage source.

The LED current is set by an external sense resistor inserted between the feedback pin (FB) and GND.

A regulation loop holds the voltage drop at the sense resistor at a constant level (typ. 100 mV).



1 Schematic

Figure 1. Schematic

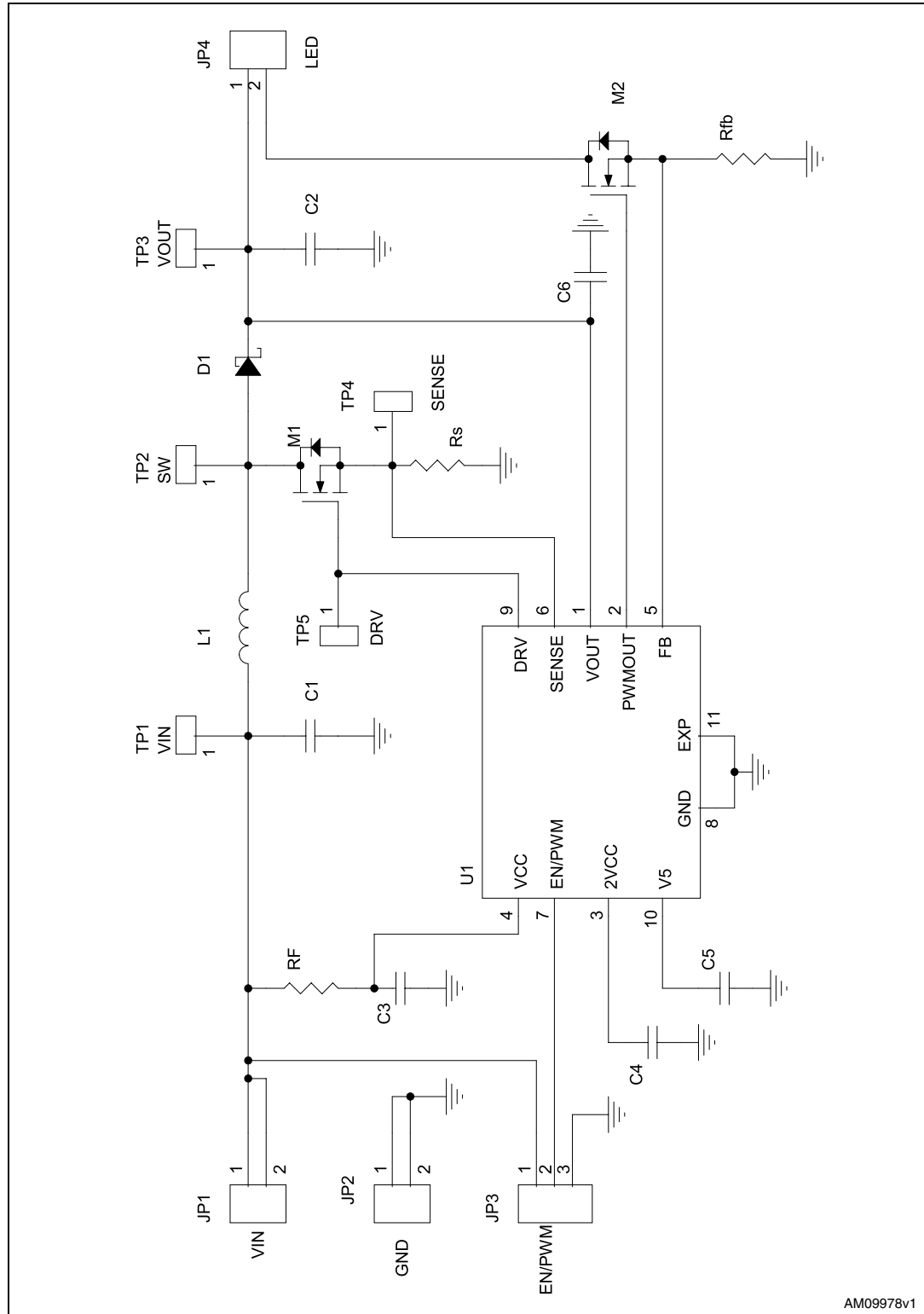

AM09978v1

2 Revision history

Table 1. Document revision history

Date	Revision	Changes
08-Nov-2011	1	Initial release.