



# STEVAL-ILL045V1

9 W, A19 format Triac dimmable, high power factor, non-isolated LED driver based on the HVLED815PF (for US market)

Data brief

## Features

- 9 W output, for light equal to a range from 40 W to 60 W incandescent
- +/-5% primary-side current regulation, no optocoupler
- Low component count - 25 parts, including the EMI filter
- Only 1 tight-tolerance component
- High efficiency, > 86%
- High power factor > 0.98 and low THD, < 20% over 90 V to 132 V range
- Fits in 28 mm tubing, 52 mm overall length
- Dimmable with common Triac dimmer
- RoHS compliant

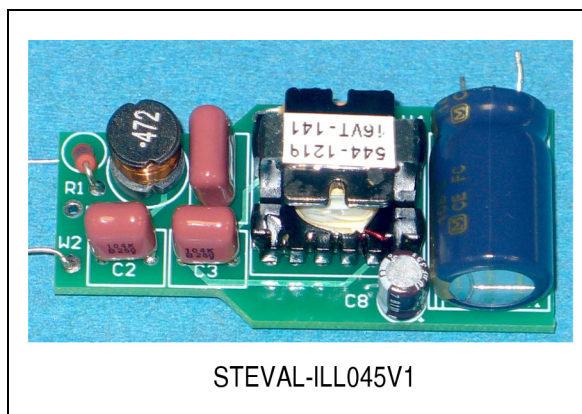

The circuit regulates LED current over a wide range of line voltage and LED string voltage, and it is dimmable with standard Triac-based dimmers.

## Description

The STEVAL-ILL045V1 demonstration board showcases ST's new LED driver chip, HVLED815PF. It solves the problem of low-cost drive circuitry for LED replacements for 40 W incandescent or equivalent compact-fluorescent lamps.

The HVLED815PF is a new integrated power controller using primary-side control to achieve LED current regulation within +/-5%. (It also has primary-side voltage regulation, used here for open load protection.)

The device incorporates an 800 V avalanche-rated FET and fits a standard SO-16 package. An internal startup circuit eliminates the need for external rapid-start circuitry.

The PFC-flyback power converter operates in transition mode for the highest efficiency and best use of components.

With the addition of a few extra components the HVLED815PF is made to draw near-sinusoidal input current from the AC line.

# 1 Schematic diagram

Figure 1. Schematic diagram

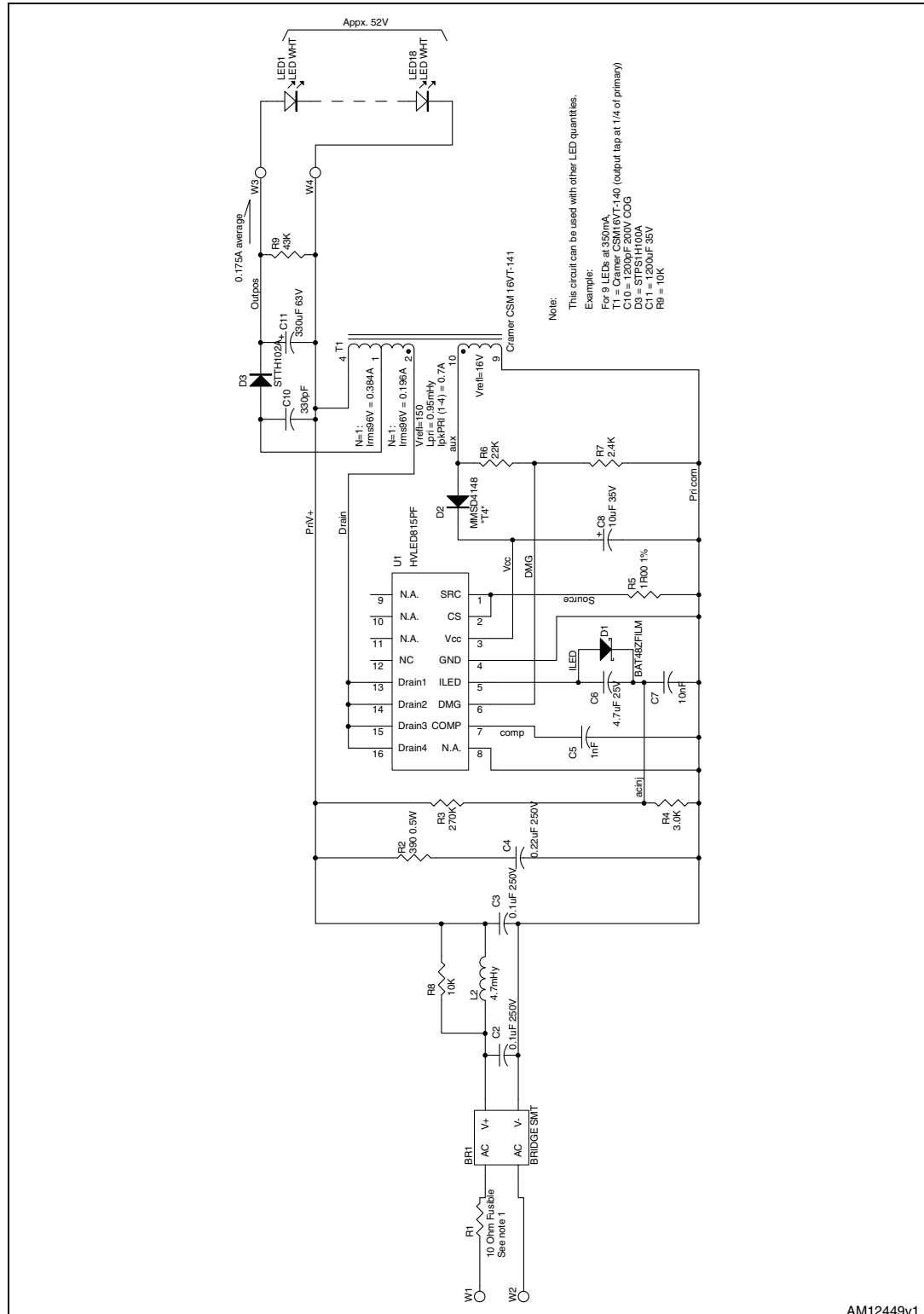

AM12449v1

## 2 Revision history

Table 1. Document revision history

Date	Revision	Changes
29-Jun-2012	1	Initial release.