

## HB LED driver with inhibit based on the ST1CC40 in an SO-8 BW package

Data brief

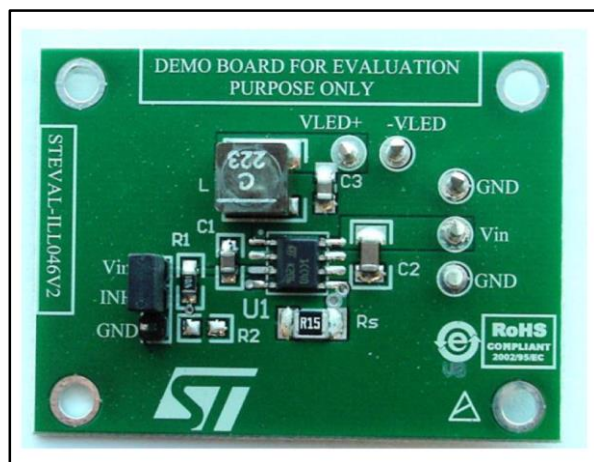

### Features

- 3 to 18 V operating input voltage range
- 850 kHz fixed switching frequency
- 100 mV (typ) current sense voltage drop
- 6  $\mu$ A standby current in inhibit mode
- $\pm 7\%$  output current accuracy
- Synchronous rectification
- Embedded compensation network
- Internal current limiting
- Ceramic output capacitor compliant
- Thermal shutdown
- RoHS compliant

### Description

The STEVAL-ILL046V2 evaluation board is based on the ST1CC40, which is an 850 kHz fixed switching frequency monolithic step-down DC-DC converter designed to operate as a precise constant current source with an adjustable current capability of up to 3 A DC.

In closed loop operation, the ST1CC40 feedback pin voltage is 100 mV, thus the sensing resistor calculation is expressed as  $R_s = 100 \text{ mV}/I_{LED}$ .

The STEVAL-ILL046V2 is provided with 660 mA by connecting a 150 mW sensing resistor to the feedback pin.

The overall application size is minimized, thanks to the high switching frequency and ceramic output capacitor compatibility.

The STEVAL-ILL046V2 evaluation board is fully protected against overheating, overcurrent and output short-circuit.

The inhibit mode minimizes the current consumption in standby (6  $\mu$ A) to maximize battery life in portable devices.

# 1 Schematic diagram

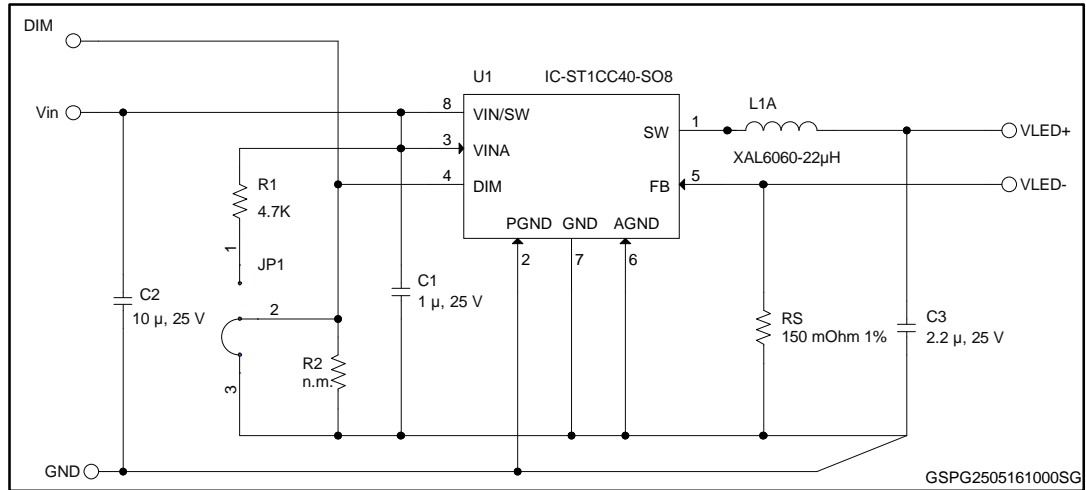
**Figure 1: STEVAL-ILL046V2 circuit schematic**

## 2 Revision history

Table 1: Document revision history

Date	Version	Changes
11-Feb-2013	1	Initial release.
25-May-2016	2	Updated: Figure 2 STEVAL-ILL046V2 circuit schematic.