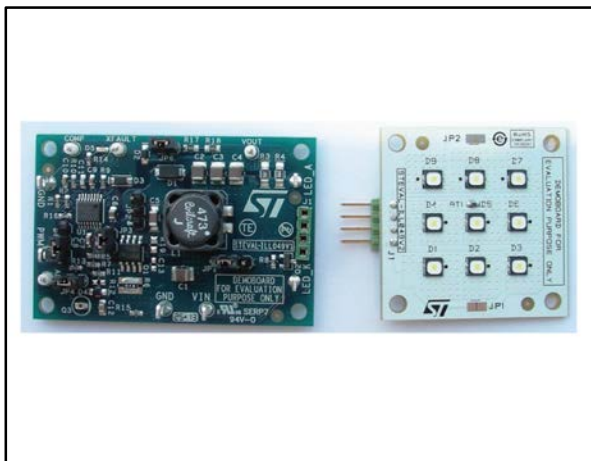

LED driver based on the LED6001 + 9-LED board with NTC sensor

Data brief

**Description**

The purpose of this product evaluation board is to provide an application example of a compact LED driver using the new LED6001 chip from STMicroelectronics. The board is equipped with a single-channel, constant-current LED driver operating with both boost and SEPIC topologies. The brightness of the LED string connected to its output can be controlled through a PWM signal (0%-100% dimming) or a control voltage (10:1 analog dimming). Open LED, feedback disconnection, LED overcurrent and output-to-ground short-circuit (SEPIC only) faults are detected and managed. The board has been designed to provide a solution example for applications involving several LEDs arranged as a single string (e.g. off-grid street lighting, advertisement panels, signs, gaming, etc.).

Features

- Wide DC input voltage: 6 V-24 V
- Single channel, 350 mA constant-current output with PWM brightness control
- Up to 10 high-brightness white LEDs (40 V OVP threshold)
- Selectable boost or SEPIC converter topology
- Up to 92% efficiency (boost converter)
- Onboard photo-transistor for ambient light switch function
- LED temperature protection through analog dimming control
- RoHS compliant

1 Schematic diagram

Figure 1: Circuit schematic

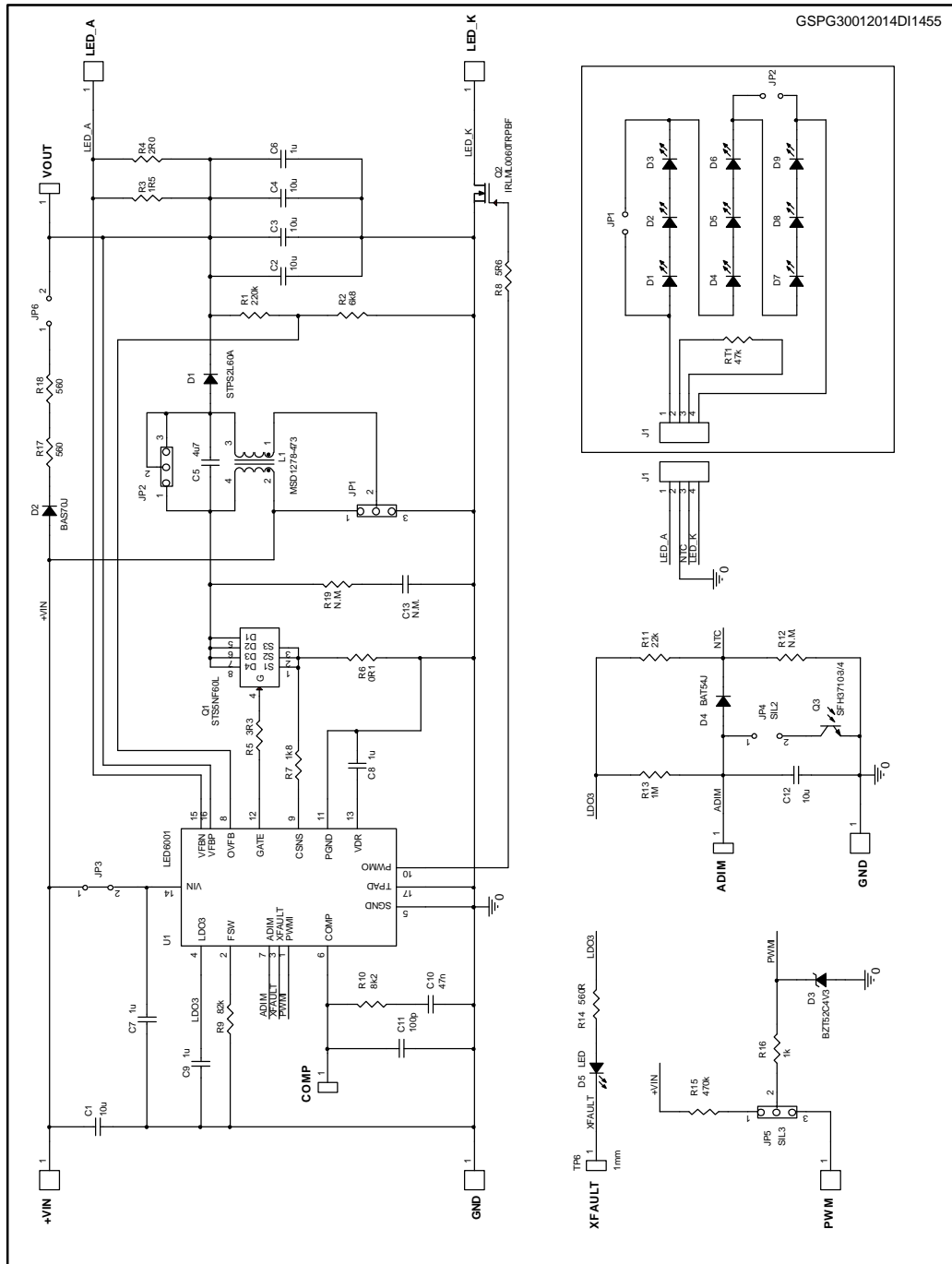

2 Revision history

Table 1: Document revision history

Data	Revision	Changes
29-Jul-2014	1	Initial release