

3 A HB LED driver with dimming function based on the LED2000 in a QFN package

Data brief



Features

- 3.0 V to 18 V operating input voltage range
- 850 kHz fixed switching frequency
- 100 mV typical current sense voltage drop
- PWM dimming
- $\pm 7\%$ output current accuracy
- Synchronous rectification
- Internal current limiting
- Thermal shutdown
- RoHS compliant

Description

The purpose of the STEVAL-ILL051V2 evaluation board is to aid in the evaluation of the LED2000, an 850 kHz fixed switching frequency monolithic step-down DC-DC converter. The LED2000 is designed to operate as a precise constant current source with an adjustable current capability up to 3 A DC.

The embedded PWM dimming circuitry features LED brightness control. The regulated output current is set by connecting a sensing resistor to the feedback pin.

The size of the overall application is minimized thanks to the high switching frequency and ceramic output capacitor compatibility.

The device is fully protected against overheating, overcurrent and output short-circuit.

1 Schematic diagram

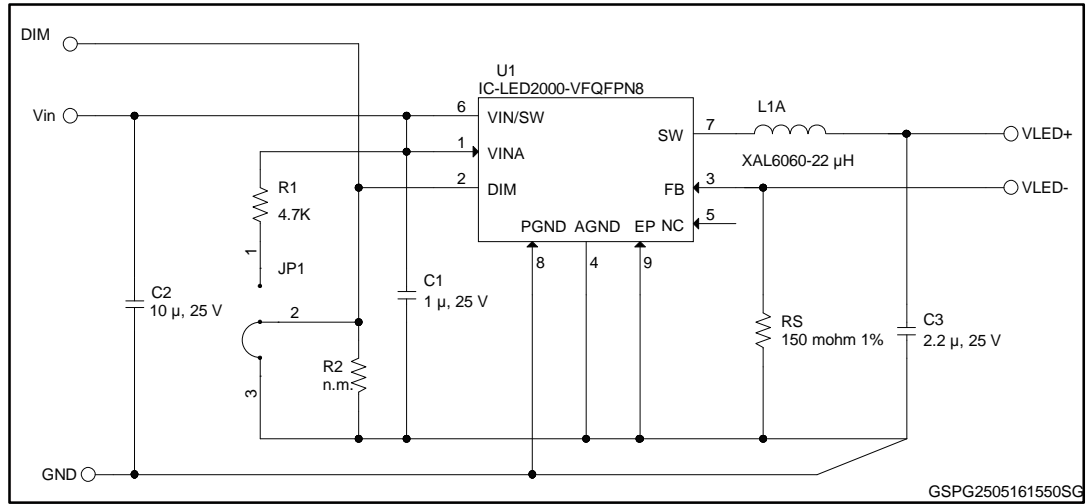
Figure 1: STEVAL-ILL051V2 circuit schematic

2 Revision history

Table 1: Document revision history

Date	Version	Changes
22-Feb-2013	1	Initial release.
26-May-2016	2	Updated: Figure 1 STEVAL-ILL051V2 circuit schematic.