

## 4 A HB LED driver with dimming function based on the LED2001 in an HSOP8 package

Data brief

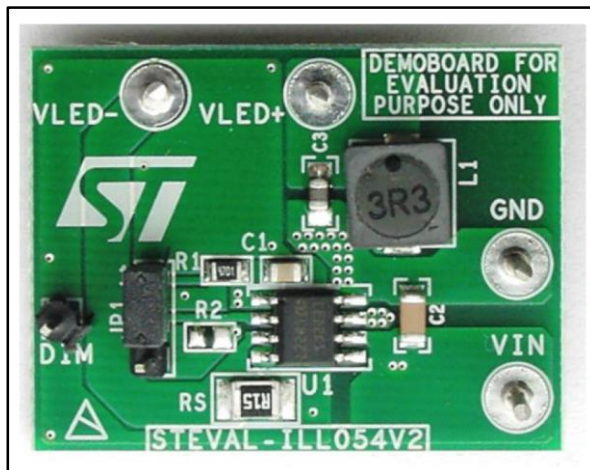

### Features

- 3.0 V to 18 V operating input voltage range
- 850 kHz fixed switching frequency
- 100 mV typical current sense voltage drop
- PWM dimming
- $\pm 7\%$  output current accuracy
- Synchronous rectification
- Internal current limiting
- Thermal shutdown
- RoHS compliant

### Description

The purpose of the STEVAL-ILL054V2 evaluation board is to aid in the evaluation of the LED2001, an 850 kHz fixed switching frequency monolithic step-down DC-DC converter. The LED2001 is designed to operate as a precise constant current source with an adjustable current capability up to 4 A DC.

The embedded PWM dimming circuitry features LED brightness control. The regulated output current is set by connecting a sensing resistor to the feedback pin.

The size of the overall application is minimized thanks to the high switching frequency and ceramic output capacitor compatibility.

The device is fully protected against overheating, overcurrent and output short-circuit.

# 1 Schematic diagram

Figure 1: STEVAL-ILL054V2 circuit schematic

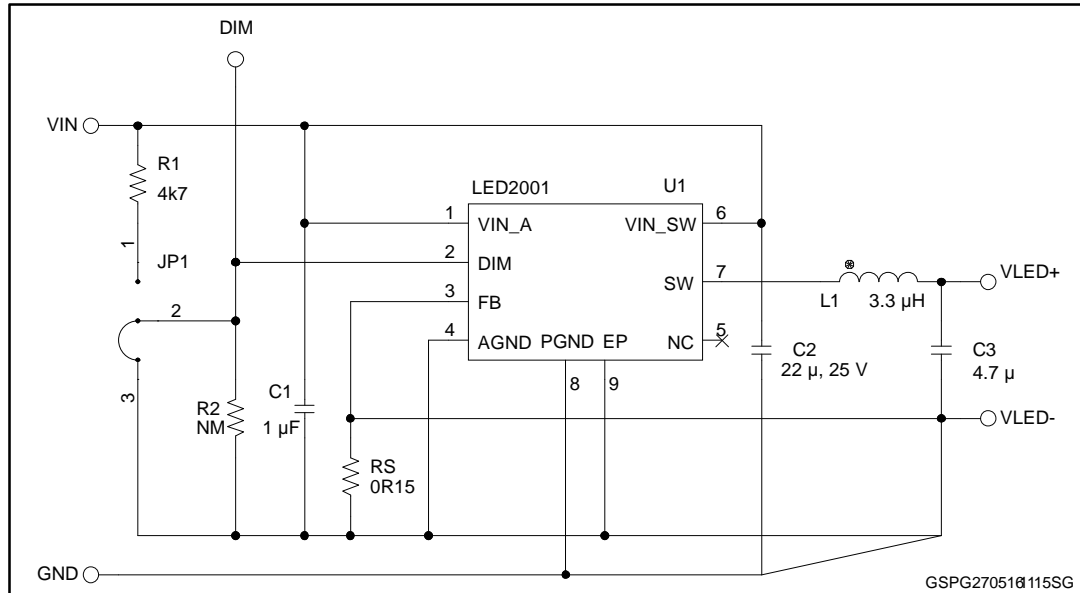

## 2 Revision history

**Table 1: Document revision history**

Date	Version	Changes
01-Aug-2013	1	Initial release.
27-May-2016	2	Updated: Figure 1 STEVAL-ILL054V2 circuit schematic.