

High-efficiency isolated offline LED drive with 11 W fixed output and high PF, based on the HVLED815PF (EU input range)

Data brief



Description

The STEVAL-ILL055V1 is an isolated SMPS designed in high power factor flyback topology. It generates a 640 mA nominal output current, delivering up to 11 W of output power and provides a cost-effective and space-saving solution. This product evaluation board is based on the HVLED815PF, a monolithic converter integrating both an 800 V avalanche-rugged MOSFET and PWM controller in a single package.

Features

- Input:
 - Voltage: 185 – 264 Vac
 - Frequency: 45 – 55 Hz
- Output:
 - Current: 640 mA
 - Voltage: 6 LED module (blue or white)
- Power factor
 - > 0.9
- Efficiency
 - 84%
- PCB type and size:
 - FR4
 - Double layer
 - Copper thickness: 35 μ m
 - LED driver size: 17 x 55 mm
 - Board size: 34 x 88 mm
- Isolation
 - Isolated 2 kV / 4 mm isolation gap
- EMI
 - According to EN55022 Class B

1 Schematic diagram

Figure 1: STEVAL-ILL055V1 circuit schematic

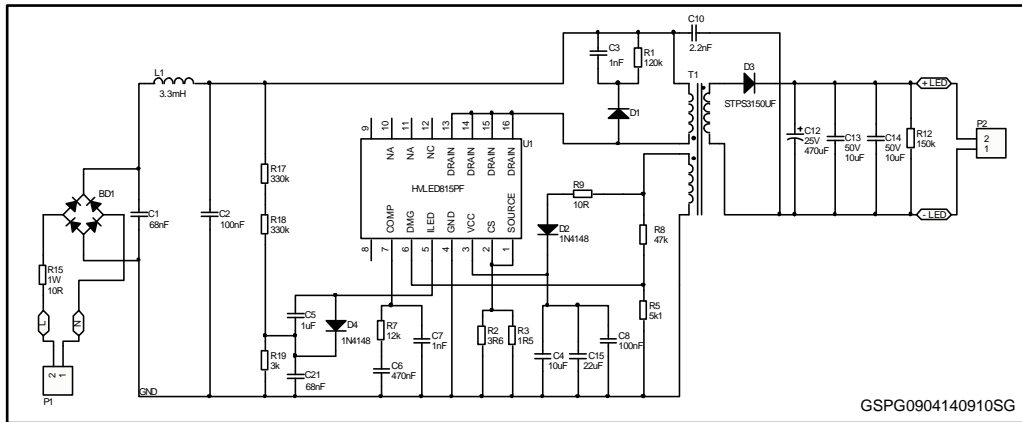

2 Revision history

Table 1: Document revision history

Data	Revision	Changes
14-Apr-2014	1	Initial release