

High brightness LED array driver based on the STP16CPC26

Data brief



Description

The STEVAL-ILL062V1 evaluation board is a high brightness LED array driver application based on the 16 channel, constant current LED sink driver STP16CPC26 from STMicroelectronics.

The LED driver is configured and controlled through an 8-bit STM8S microcontroller via SPI interface.

The industrial-grade L7981D DC-DC converter provides the voltages and power for the overall functioning of the board.

Features

- Demonstrates pre-configured patterns (with adjustable brightness/speed) such as rolling text, wave effect, dot sequence, etc.
- LED test points
- Potentiometer to change brightness and speed of patterns
- SWIM connector to program microcontroller
- Push buttons (backward/forward) to change between modes
- DC supply connector: 6 V - 24 V
- 32 white LEDs
- RoHS compliant

Figure 3. Jumpers to simulate open circuit

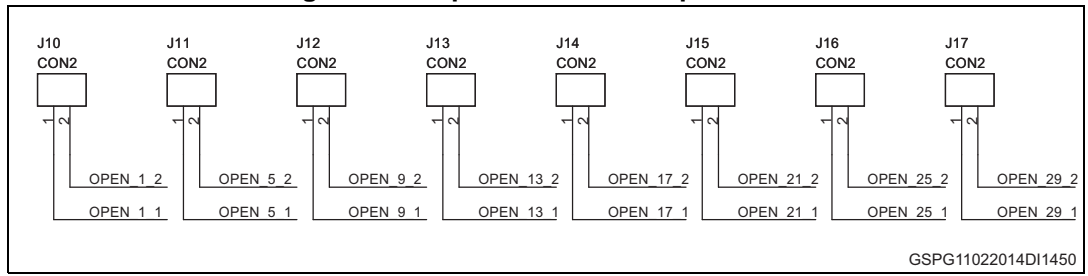
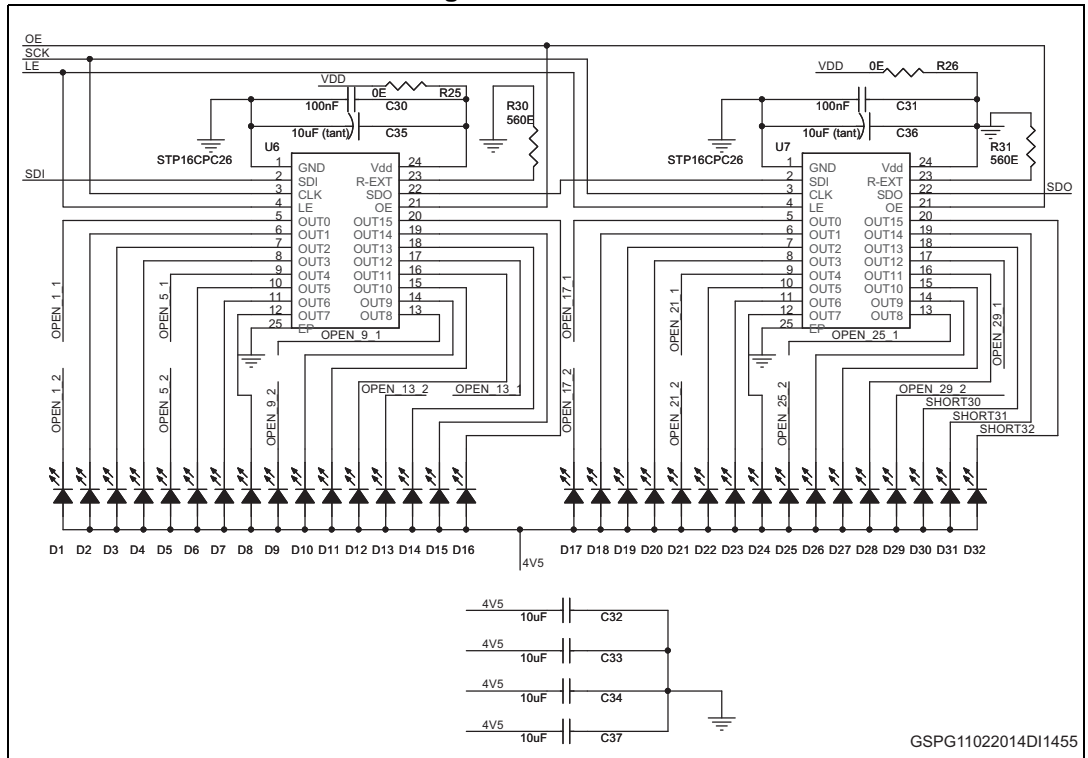

Figure 4. LED driver



2 Revision history

Table 1. Document revision history

| Date | Revision | Changes |
|-------------|----------|------------------|
| 07-Aug-2014 | 1 | Initial release. |