

## 3 A LED driver based on the LED5000 in BB+ topology

Data brief



### Features

- 5.5 V to 48 V operating input voltage range
- 850 kHz fixed switching frequency
- 200 mV typ. current sense voltage drop
- BB+ boost topology
- PWM dimming
- $\pm 3\%$  output current accuracy over temperature
- 200 mOhm typical  $R_{\text{DS(on)}}$
- Peak current mode architecture

- Short-circuit protection
- Compliant with ceramic output capacitors
- Inhibit for zero current consumption
- Thermal shutdown
- RoHS compliant

### Description

The STEVAL-ILL065V1 is a product evaluation board based on the LED5000, an 850 kHz fixed switching frequency monolithic step-down DC-DC converter designed to operate as a precise constant current source with an adjustable current capability up to 3 A DC.

The embedded PWM dimming circuitry features LED brightness control. The regulated output current level is set by connecting a sensing resistor to the feedback pin. The 200 mV typical  $R_{\text{SENSE}}$  voltage drop enhances performance in terms of efficiency.

The size of the overall application is minimized thanks to the high switching frequency and its compatibility with ceramic output capacitors. The device is fully protected against overheating, overcurrent and output short-circuit.

# 1 Board schematic

Figure 1: Schematic

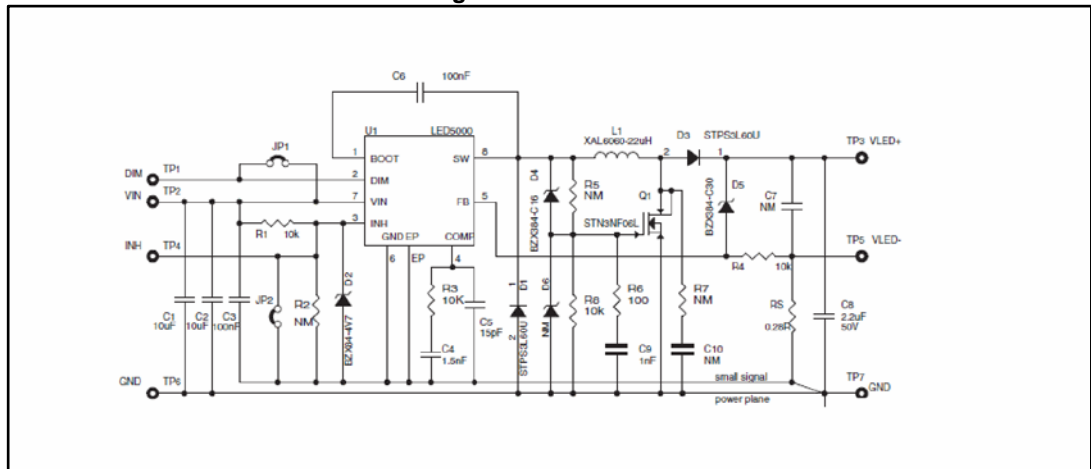

## 2 Revision history

Table 1: Document revision history

Date	Revision	Changes
25-Aug-2014	1	Initial release.