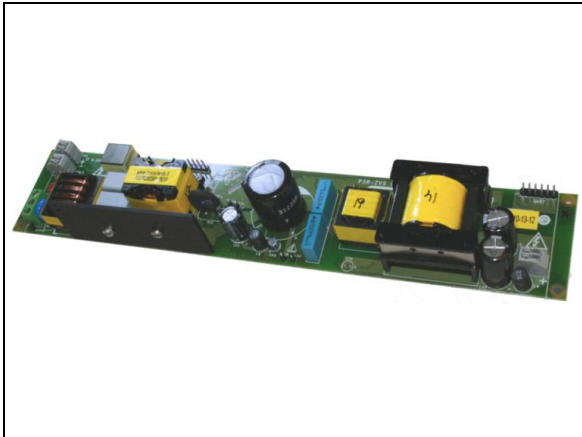

100 W LED street lighting evaluation board using STLUX385A

Data brief

**Features**

- STLUX385A based
- High efficiency (92%)
- Primary side controlled
- Up to 100 W (100 V at 1 A or 200 V at 0.5 A)
- Single isolated output suitable for LED connection.
- Wide input voltage range: 90 V to 265 V AC
- Adjustable LED current and dimming
- Output resolution: 11-bit equivalent.
- IDLE mode power consumption: < 200 mW
- Real-time fault detection and protection (e. g.: short- or open circuit)
- Remote control via DALI, 0 - 10 V, UART
- RoHS compliant

Description

The STEVAL-ILL066V1 evaluation board is a complete and configurable solution that efficiently controls a single dimmable high brightness LED string using the STLUX385A digital controller.

The LED efficiency is high during all stages of dimming and the STEVAL-ILL066V1 can achieve a 92% efficiency during full load while maintaining a low < 200 mW power consumption during idle periods.

The STLUX385A device handles a primary side regulated power conversion stage as well as all the supported communication links.

The power conversion stage consists of a PFC regulator followed by a “Zero Voltage Switching” (ZVS) LC resonant stage. The high precision dimming is adjusted using a primary side regulation (PSR) control technique.

The LED brightness can be dimmed by controlling the LED current down to a very low level.

The STEVAL-ILL066V1 evaluation board provides all the physical communication interfaces such as a DALI, insulated 0-10 and UART. All the communication is managed by the STLUX385A device. The UART interface and STLUX385A flexibility allow to quickly connect the STEVAL-ILL066V1 to alternative interfaces such as Wi-Fi, power line modems, Bluetooth® and Zigbee®. (Previous part number was STEVAL385LEDPSR).

1 Board description

Figure 1. STEVAL-ILL066V1 evaluation board

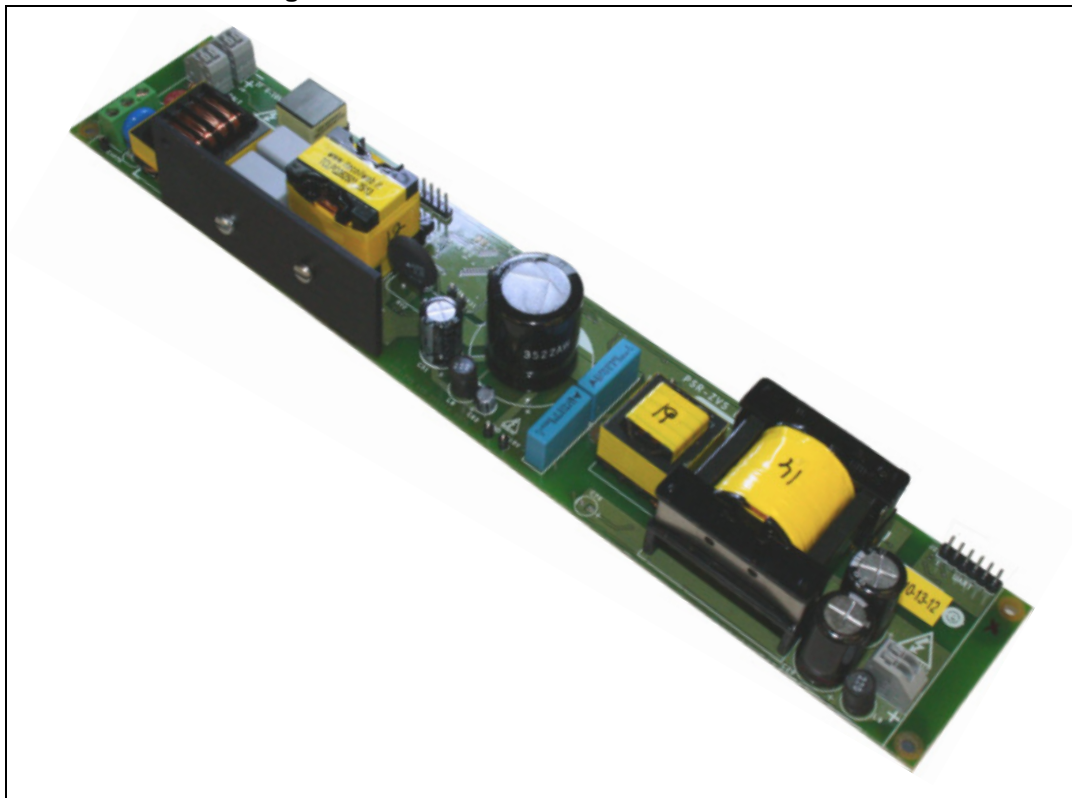

Board connector pinout

Table 1. Connector J8 pinout - AC-DC input

Name	Type	Function
ACIN	Power	Main AC/DC input
ACIN	Power	Main AC/DC input
EARTH	Power	Protective earth connection

Table 2. Connector J4 pinout - DC output

Name	Type	Function
"+"	Power	Positive load connection
"_"	Power	Negative load connection

Table 3. Connector J3 pinout - DALI interfaces

Name	Type	Function
DALI	DALI signal	DALI signal for isolated DALI interfaces - without polarization
DALI	DALI signal	DALI signal for isolated DALI interfaces - without polarization

Table 4. Connector J9 pinout - 0 - 10 V

Name	Type	Function
“+”	Positive reference	Positive reference for isolated 0 - 10 V interfaces
“-”	Negative reference	Negative reference for isolated 0 - 10 V interfaces

Table 5. Connector J2 pinout - serial interfaces

Name	Type	Function
1 (black)	Negative power	Directly connected to isolated Serial GND
2 (brown)	CTSn	Not used - pulled down
3 (red)	Fixed positive power	5.0 V power for the UART interfaces only
4 (orange)	TXD (input)	TXD signal - RXD on STLUX
5 (yellow)	RXD (output)	RXD signal - TXD from STLUX
6 (green)	RTSn	Not connected

Table 6. Connector J1 pinout - SWIM interfaces

Name	Type	Function
1	VCC_SWIM	power reference from board
2	SWIM	SWIM signal to/from STLUX
3	GND_SWIM	Directly connected to primary GND
4	RESn	Connected to STLUX NRST pin

2 Schematic diagrams

Figure 2. PSR-ZVS evaluation board schematic - STLUX385A - top

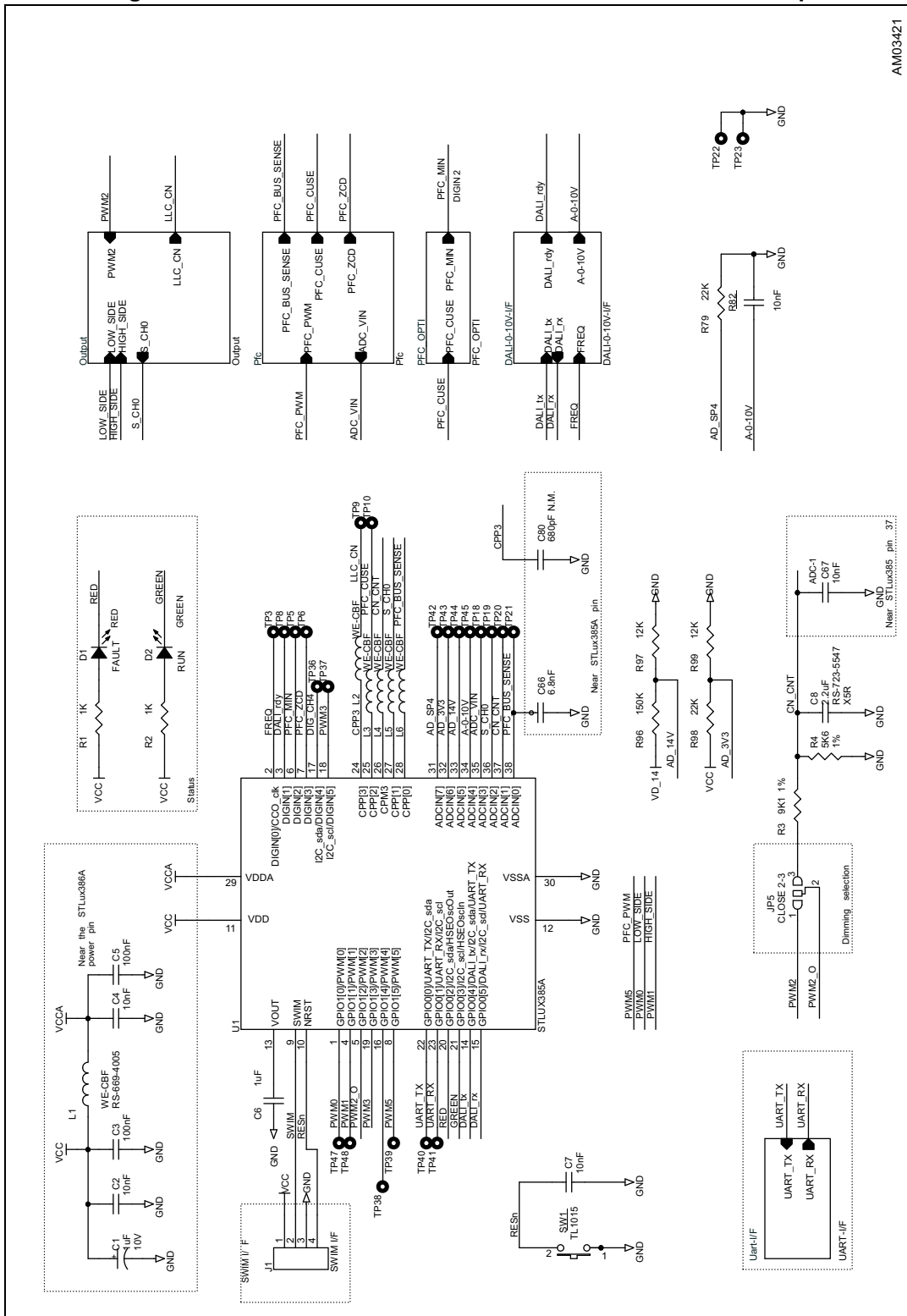

AM03421



Figure 3. PSR-ZVS evaluation board schematic - PFC and DC/DC zone

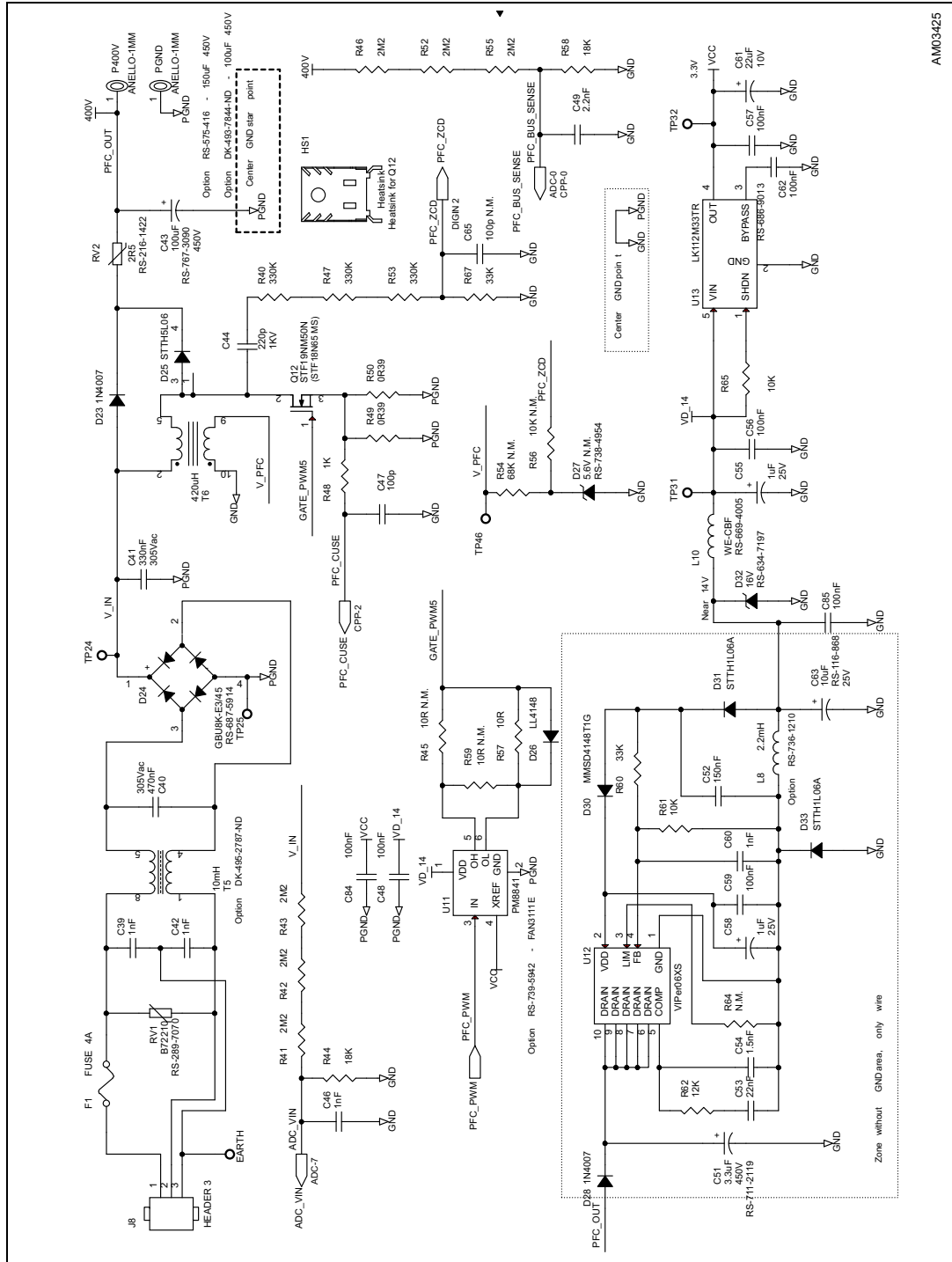
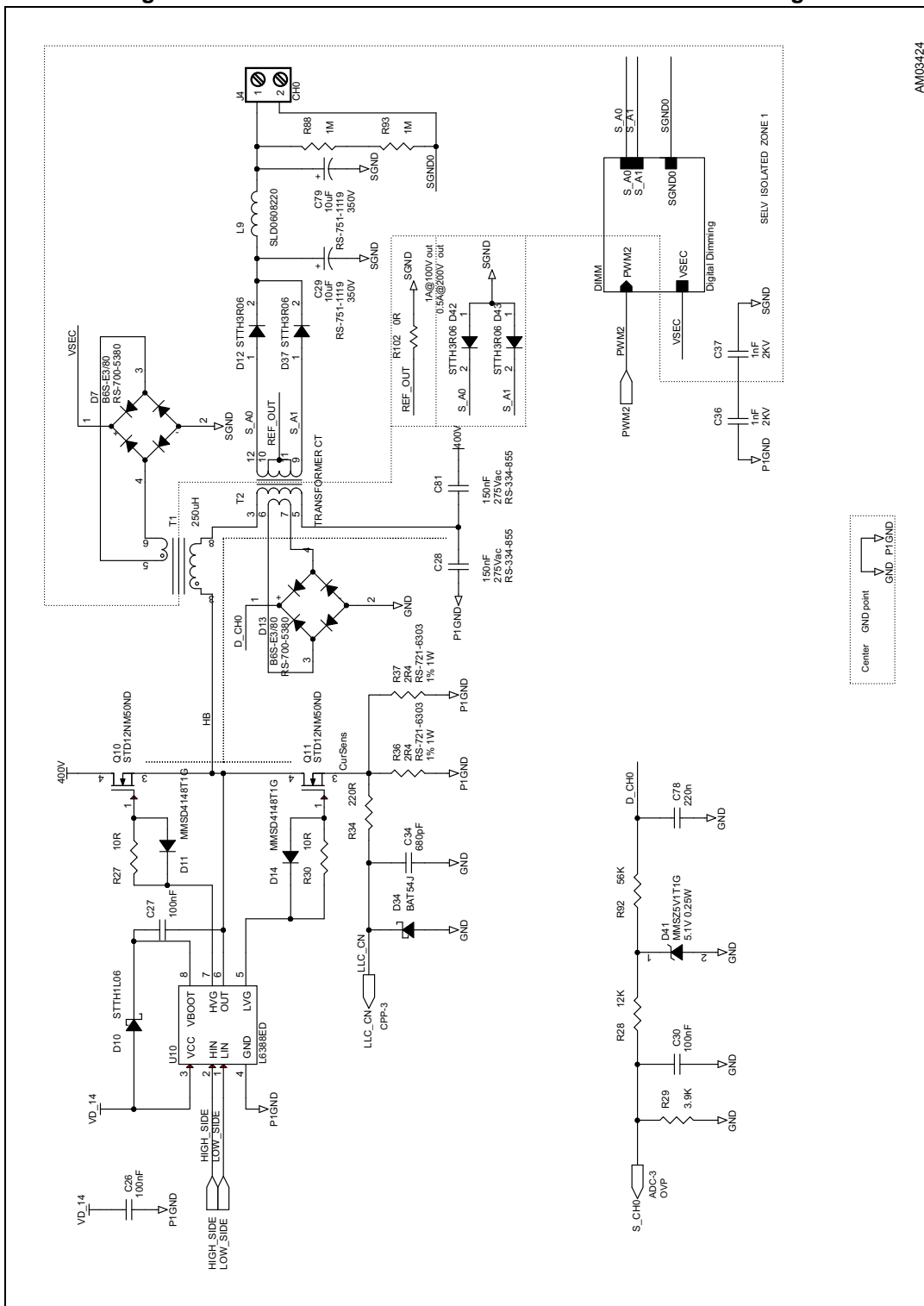

Figure 4. PSR-ZVS evaluation board schematic - PSR-ZVS stage



AM03424

Center GND point
GND, P1.GND



Figure 6. PSR-ZVS evaluation board schematic - THD optimizer

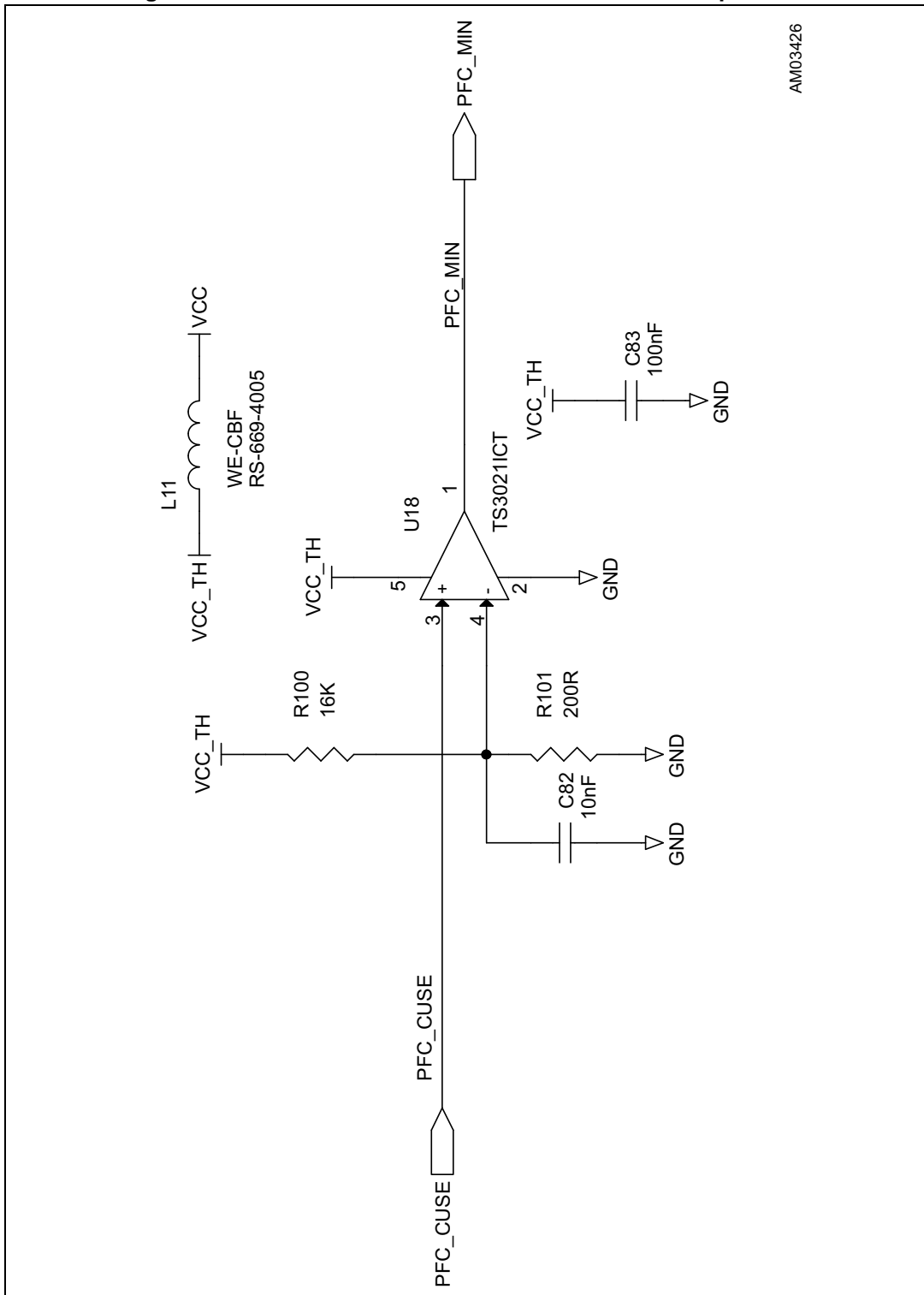
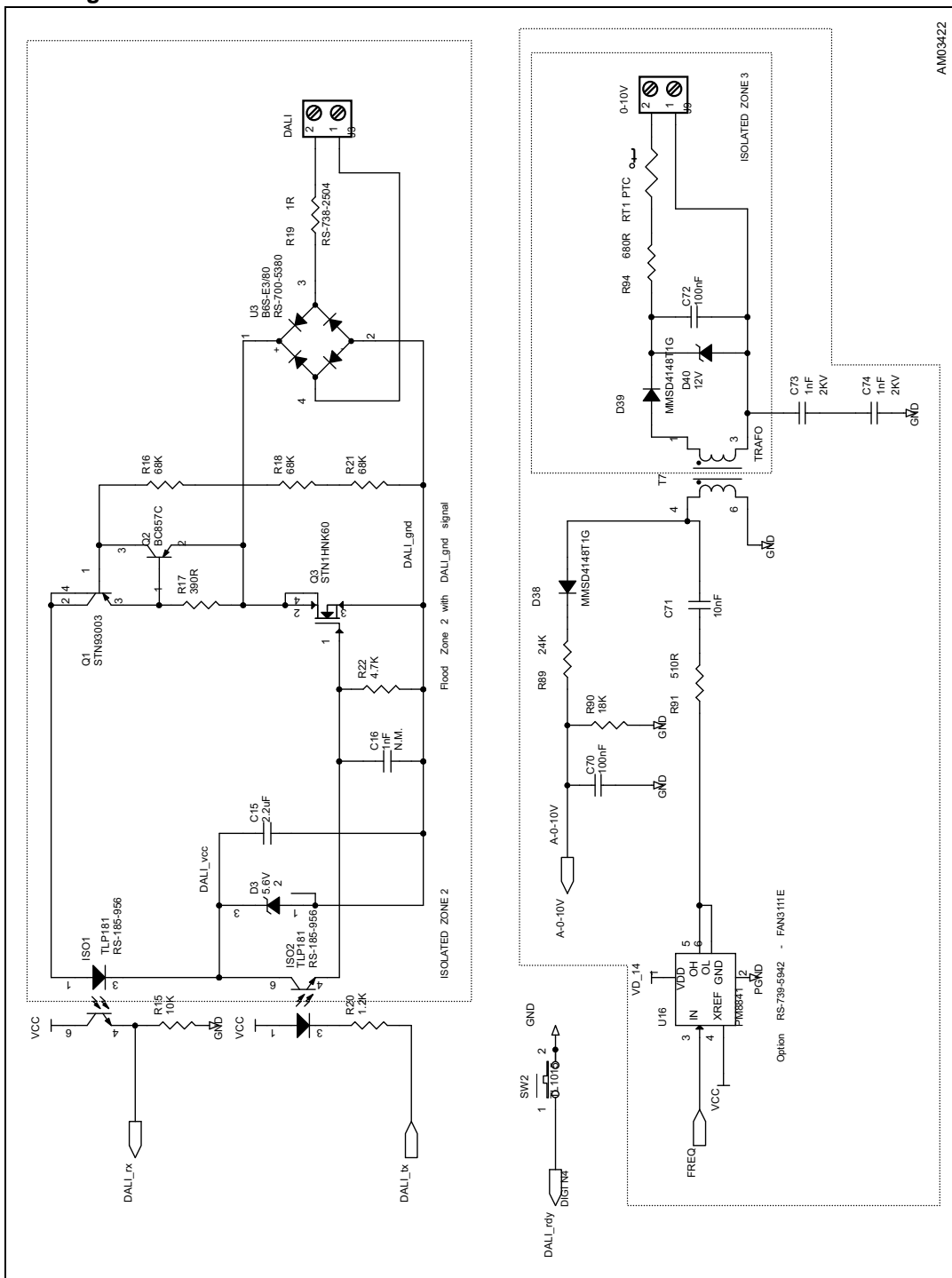
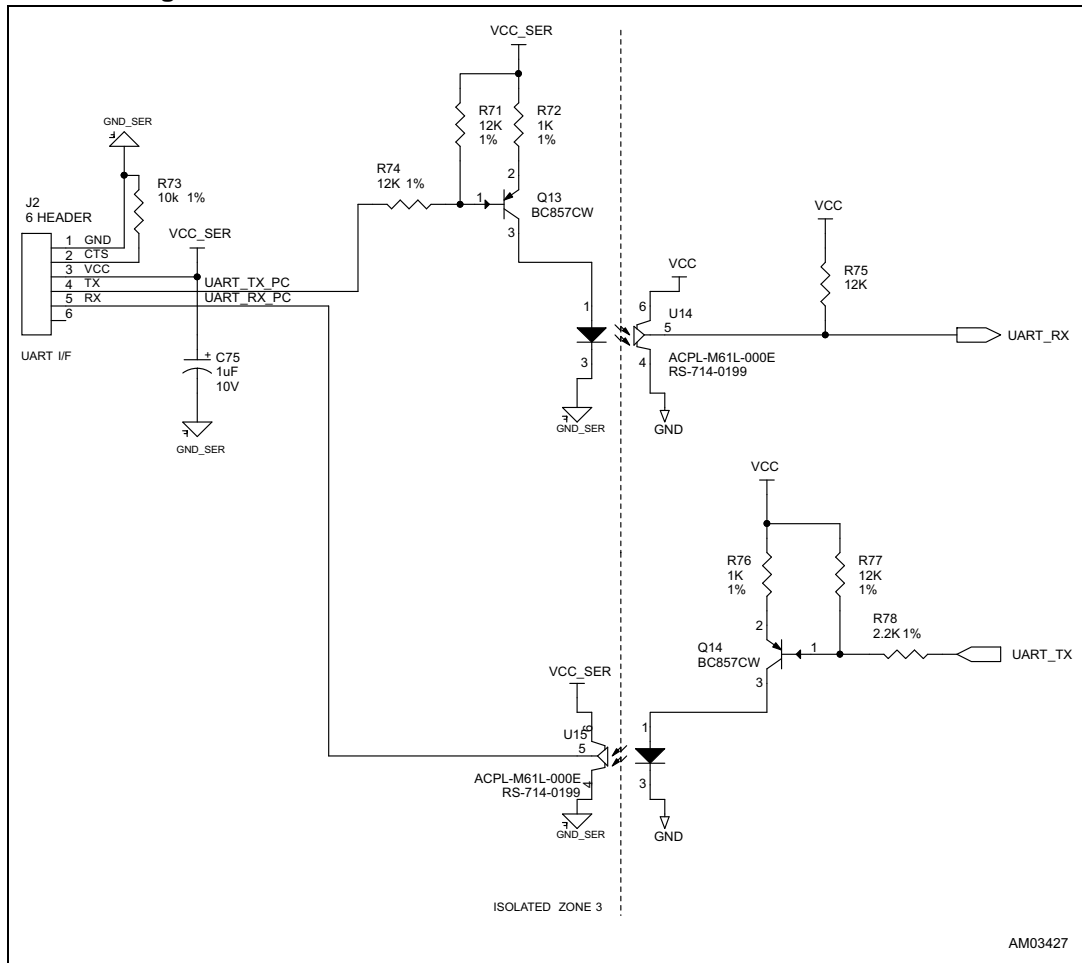

Figure 7. PSR-ZVS evaluation board schematic - DALI and 0 - 10 interfaces



AM03422

Figure 8. PSR-ZVS evaluation board schematic - serial interfaces



3 Revision history

Table 7. Document revision history

Date	Revision	Changes
06-May-2014	1	Initial release. This part number replaces the STEVAL385LEDPSR.