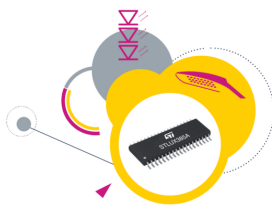


100 W LED street lighting evaluation board using the STLUX385A digital controller



Features

- based on STLUX385A digital controller
- high efficiency (92%)
- primary side controlled
- up to 100 W (100 V at 1 A or 200 V at 0.5 A)
- single isolated output suitable for LED connection
- wide input voltage range: 90 V to 265 V AC
- adjustable LED current and dimming
- output resolution: 11-bit equivalent
- IDLE mode power consumption: < 250 mW
- real-time fault detection and protection (short-circuit or open circuit)
- remote control via:
 - DALI ed.2.0
 - 0 - 10 V
 - UART
- RoHS compliant

Description

The STEVAL-ILL066V2 evaluation board is a complete and configurable solution that efficiently controls a single, dimmable, high-brightness LED string using the STLUX385A digital controller.

The LED efficiency is high during all stages of dimming: the STEVAL-ILL066V2 can achieve a 92% efficiency at full load while maintaining a low < 250 mW power consumption in idle periods and less than 500mW during failure (open or short).

The STLUX385A device handles a primary side regulated power conversion stage as well as all the supported communication links.

The power conversion stage consists of a PFC regulator followed by a “Zero Voltage Switching” (ZVS) LC resonant stage. The high precision dimming is adjusted using a primary side regulation (PSR) control technique.

The LED brightness can be dimmed by controlling the LED current down to a very low level.

The STEVAL-ILL066V2 evaluation board provides DALI, insulated 0-10 and UART physical communication interfaces, with all communication managed by the STLUX385A device.

The flexibility of the STLUX385A device and the UART interface allow quick connection of the STEVAL-ILL066V2 to various interfaces such as Wi-Fi, power line modems, NFC, Bluetooth® and Zigbee®.

Product summary	
STEVAL-ILL066V2 evaluation board	STEVAL-ILL066V2
STLUX385A digital controller for lighting and power conversion applications	STLUX385A
STSW-ILL066V2 firmware	STSW-ILL066V2

1 Overview

Figure 1. STEVAL-ILL066V2 evaluation board



Table 1. Connector J8 pinout - AC-DC input

Name	Type	Function
ACIN	Power	Main AC/DC input
ACIN	Power	Main AC/DC input
EARTH	Power	Protective earth connection

Table 2. Connector J4 pinout - DC output

Name	Type	Function
“+”	Power	Positive load connection
“-”	Power	Negative load connection

Table 3. Connector J3 pinout - DALI interfaces

Name	Type	Function
DALI	DALI signal	DALI signal for isolated DALI interfaces - without polarization
DALI	DALI signal	DALI signal for isolated DALI interfaces - without polarization

Table 4. Connector J9 pinout - 0 - 10 V

Name	Type	Function
“+”	Positive reference	Positive reference for isolated 0 - 10 V interfaces
“-”	Negative reference	Negative reference for isolated 0 - 10 V interfaces

Table 5. Connector J48 pinout - USB - serial interfaces

Name	Type	Function
1	VBUS	Power to USB interfaces area
2	USBDN	Negative USB data signal
3	USBDP	Positive USB data signal
4	ID	Not connected
5	GND	Ground reference to USB interfaces area

Table 6. Connector J1 pinout - SWIM interfaces

Name	Type	Function
1	VCC_SWIM	power reference from board
2	SWIM	SWIM signal to/from STLUX
3	GND_SWIM	Directly connected to primary GND
4	RESn	Connected to STLUX NRST pin

2 Schematic diagrams

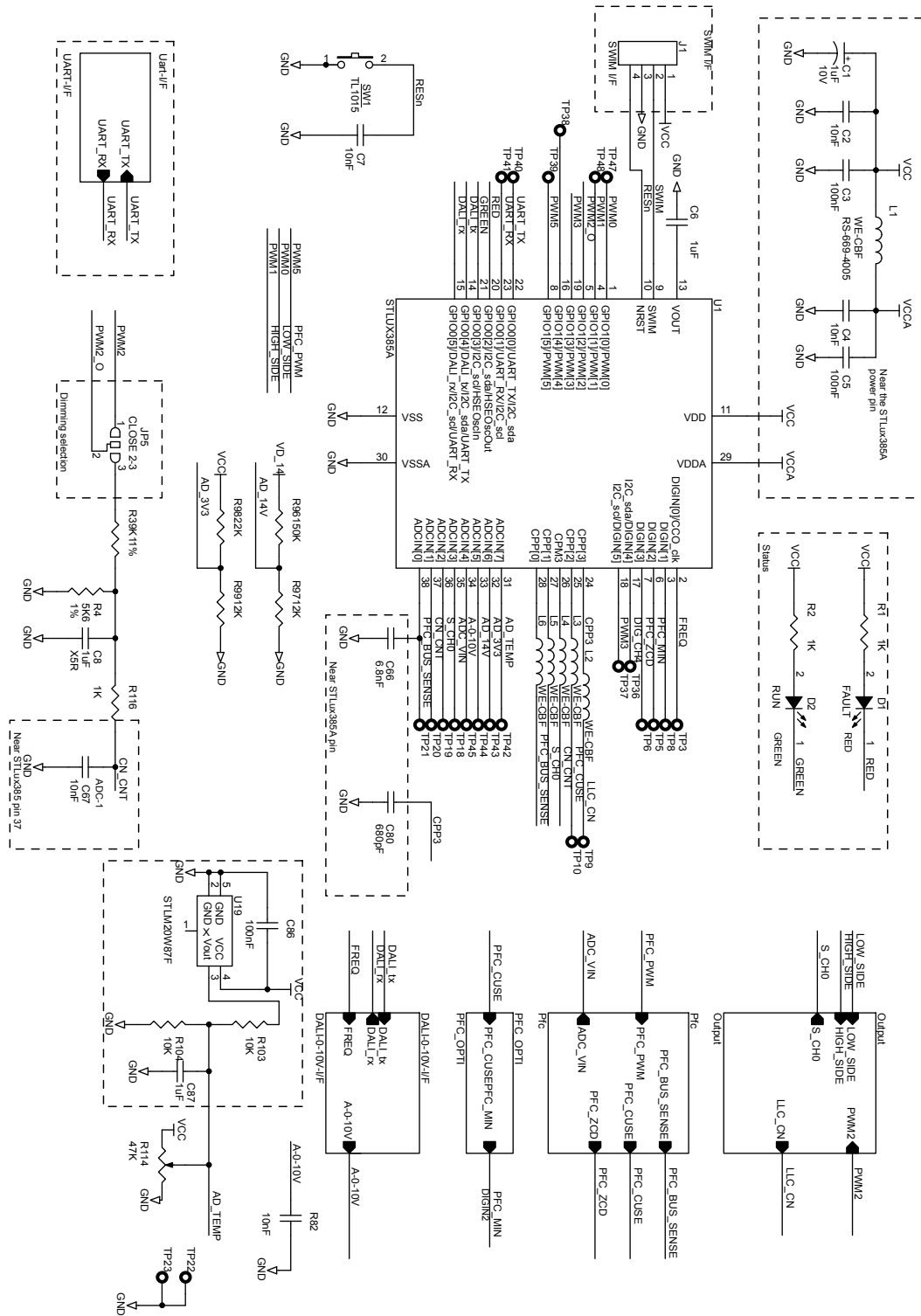
Figure 2. Schematic - STLUX385A - top


Figure 3. Schematic - PFC and DC/DC zone

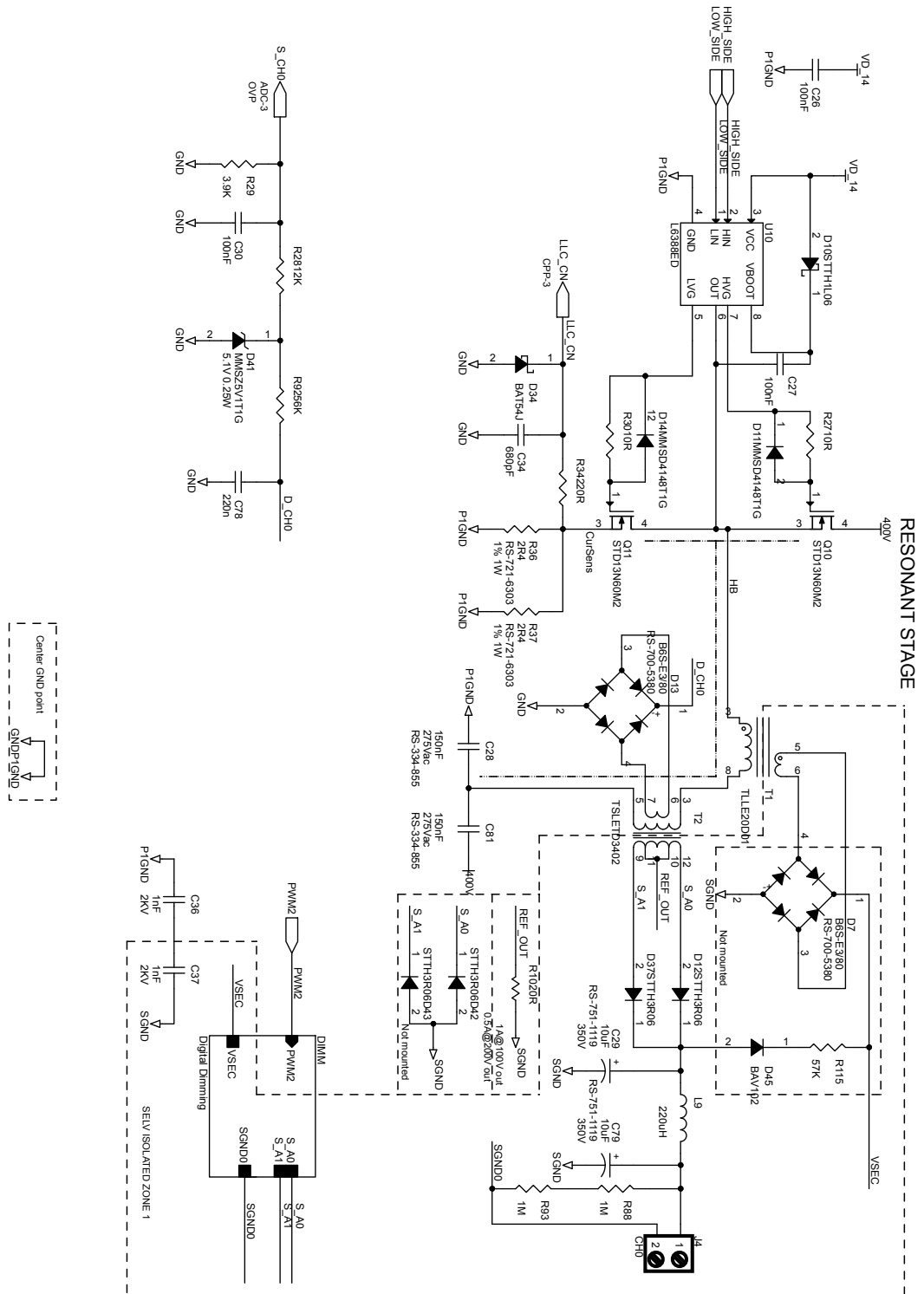


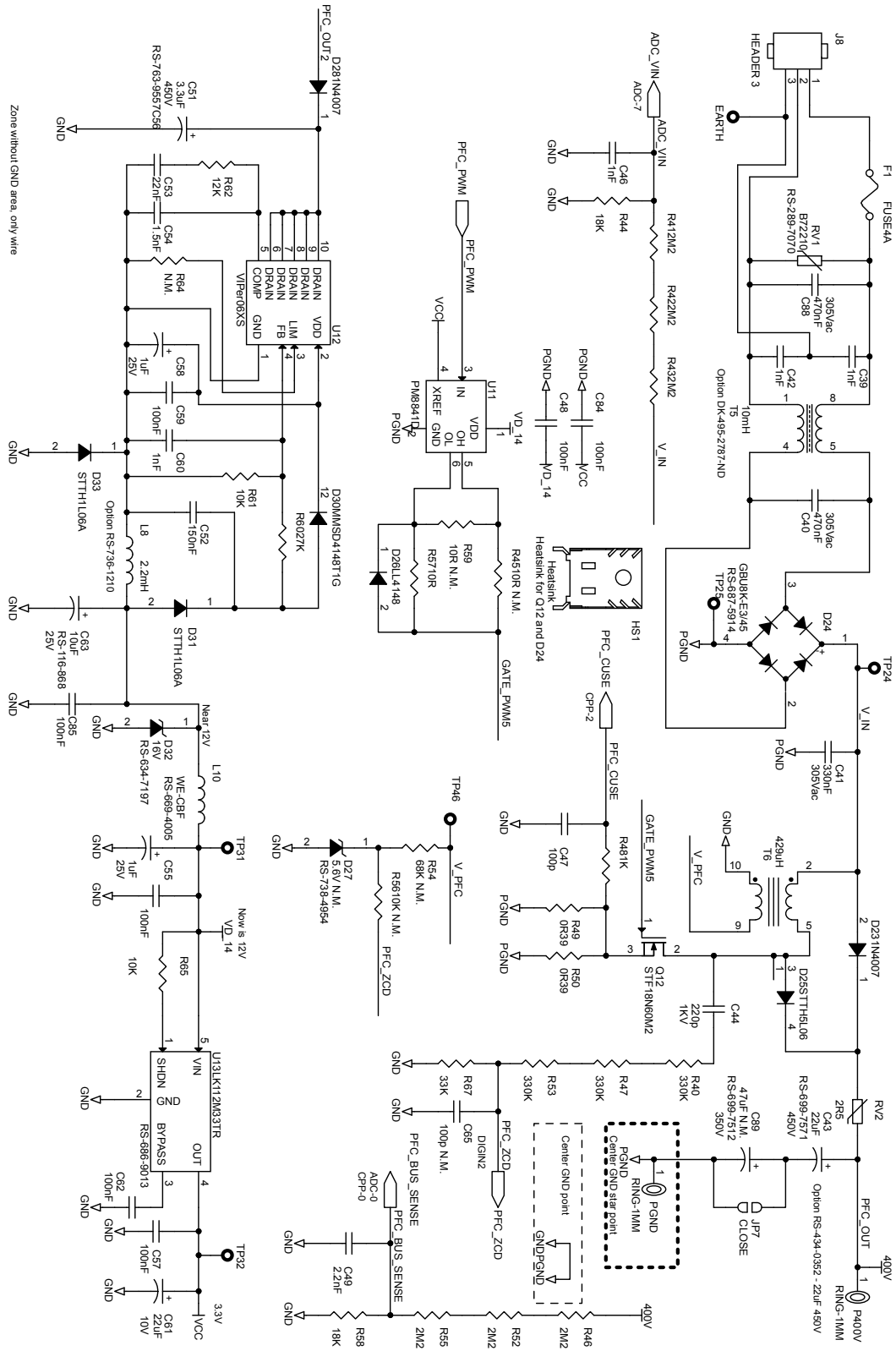
Figure 4. Schematic - PSR-ZVS stage


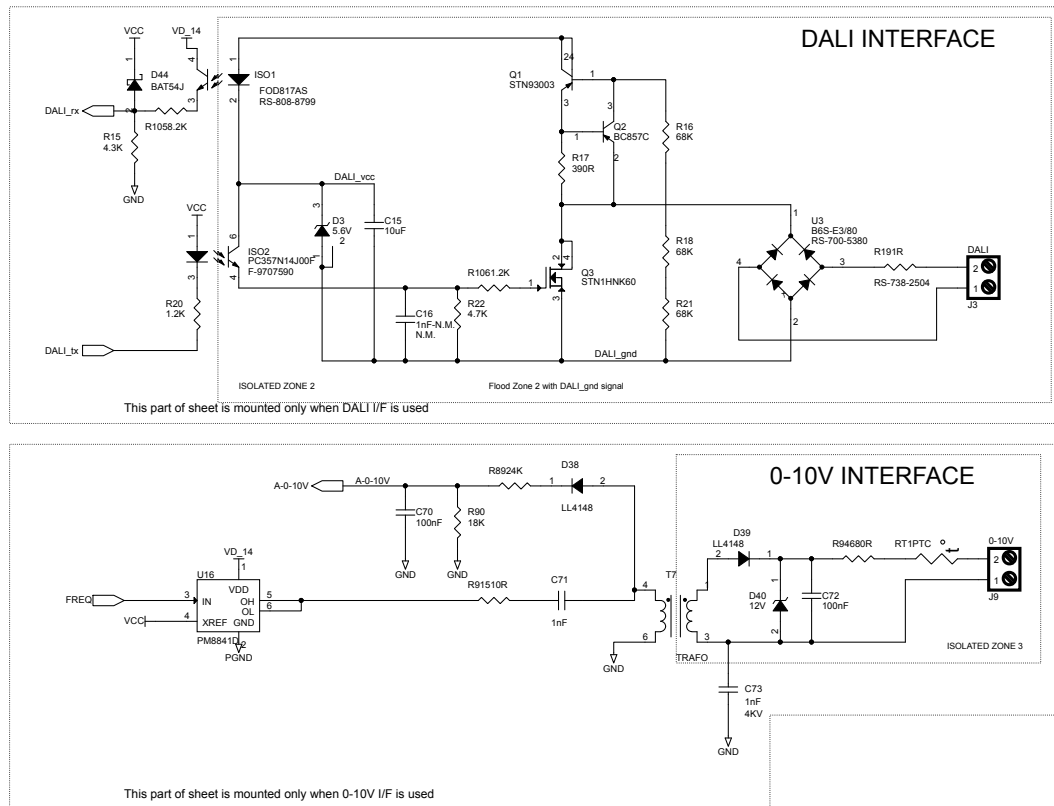
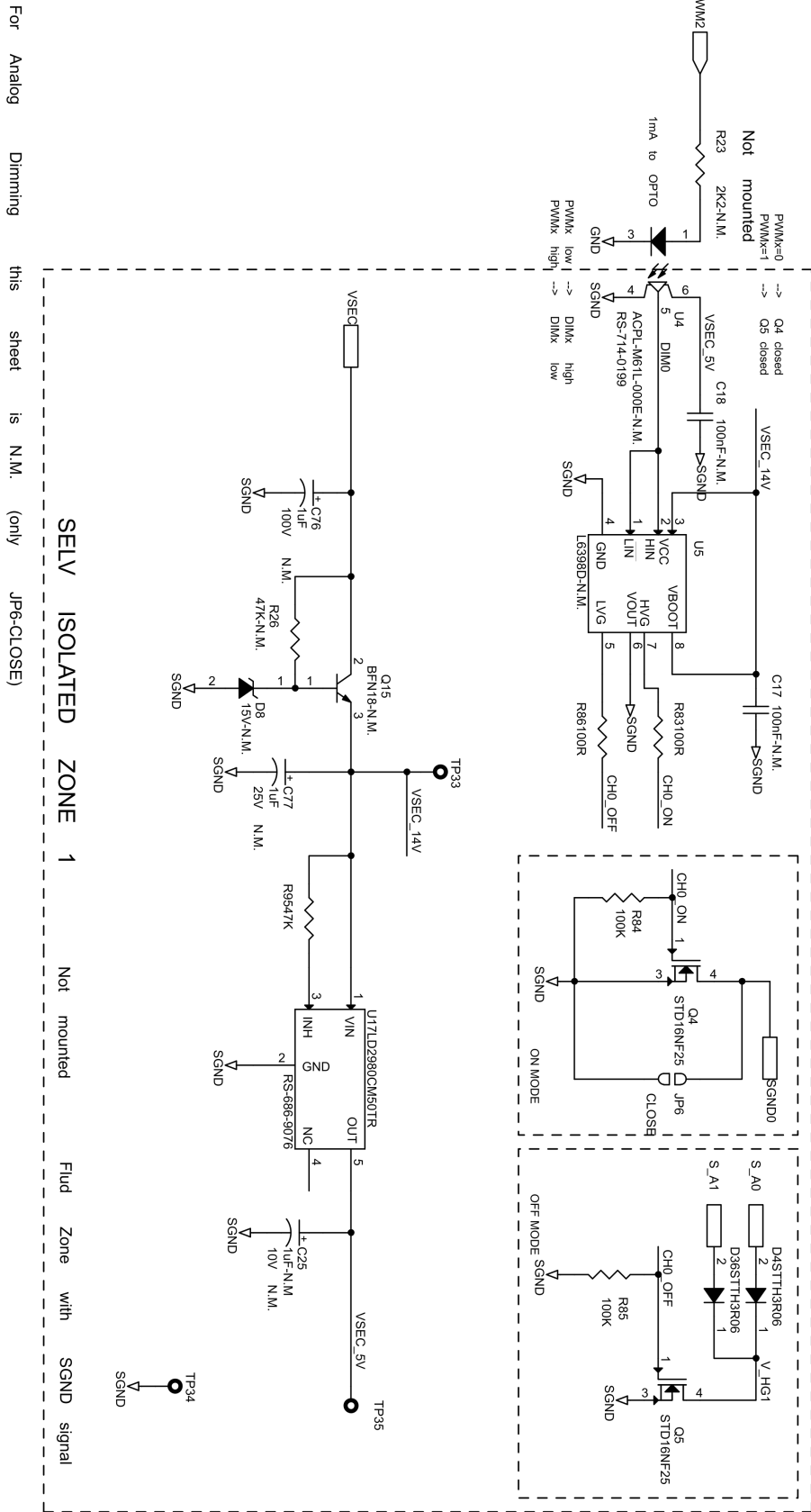
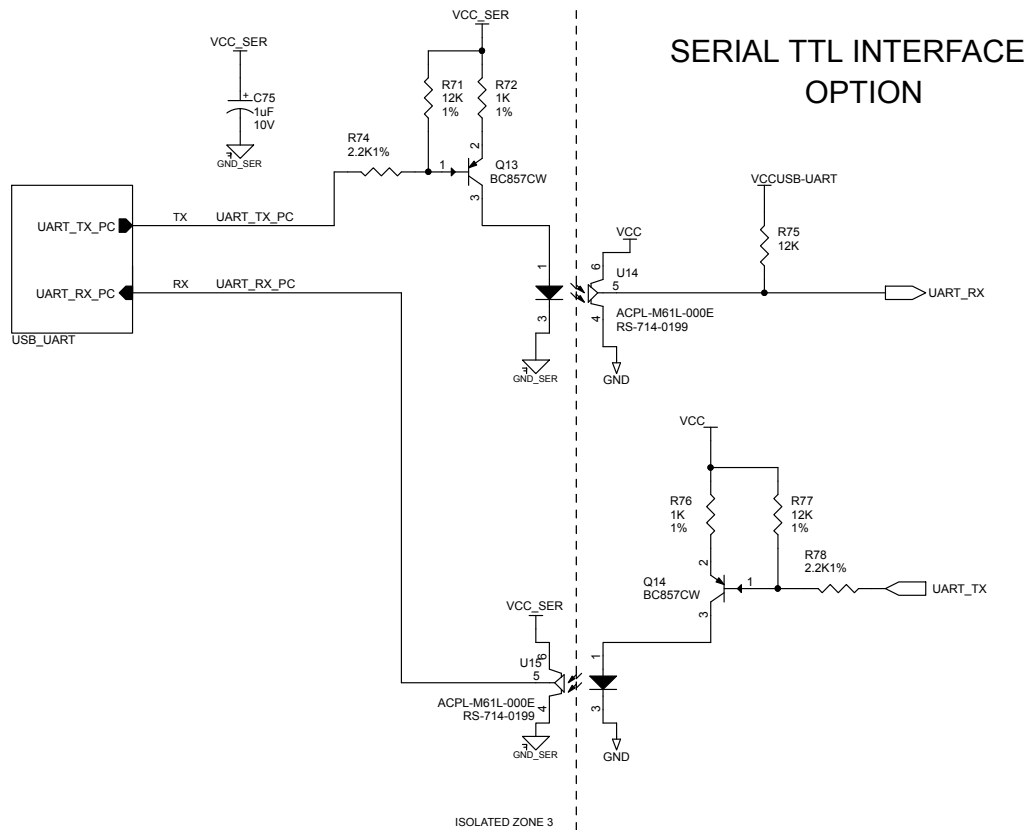
Figure 5. Schematic - digital dimming stage


Figure 6. Schematic - THD optimizer



For Analog Dimming this sheet is N.M. (only JP6-CLOSE)

SELV ISOLATED ZONE 1 Not mounted Fluid Zone with SGND signal

Figure 7. Schematic - DALI and 0 - 10 interfaces


This sheet is mounted only when UART I/F is used (only R75 is always mounted)

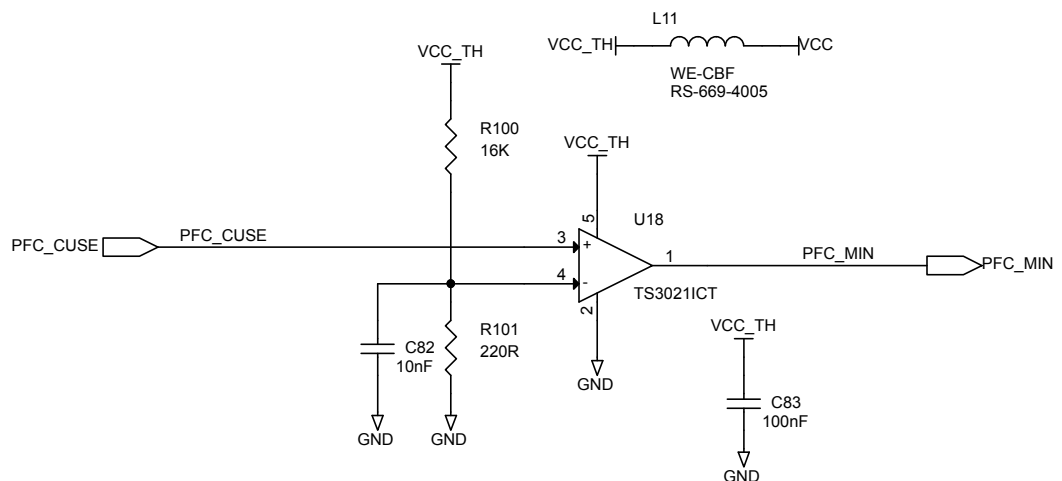
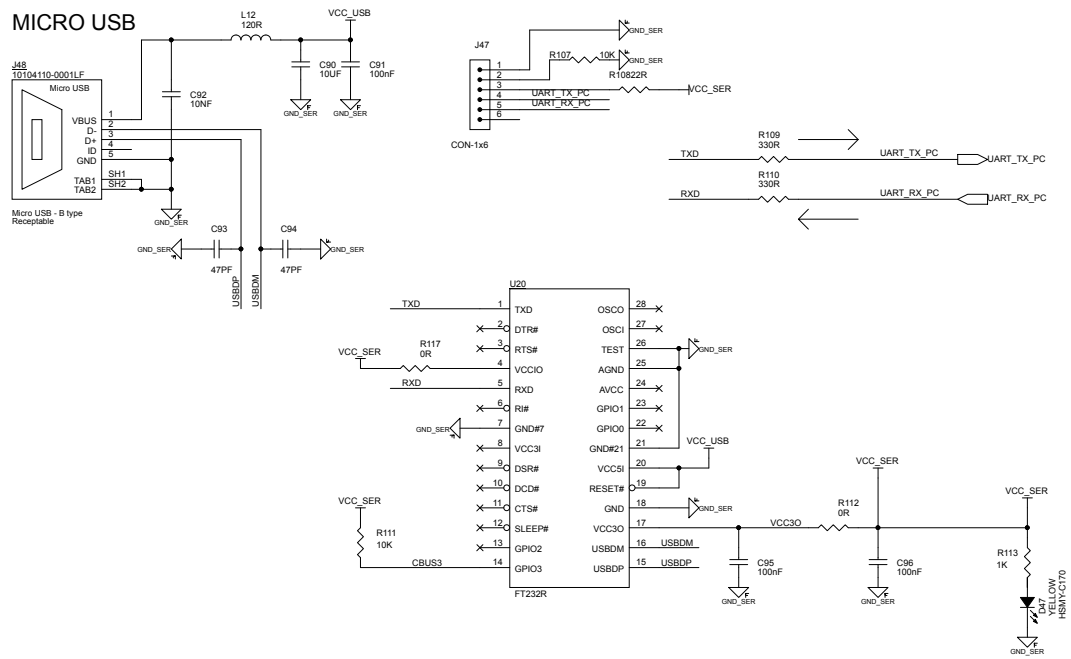
Figure 8. Schematic - serial interfaces


Figure 9. Schematic - USB interfaces


If use J48: mount R117, R111, R112, R109, R110 (default)

If use J47: remove R117, R111, R112, R109, R110

Revision history

Table 7. Document revision history

Date	Version	Changes
09-Mar-2018	1	Initial release.