

35 W wide input range flyback converter using HVLED001A quasi resonant flyback controller and STF10LN80K5

Data brief



Features

- Input voltage: V_{in} : 90 - 305 Vrms, f: 45 - 66 Hz
- Output voltage: 48 V / 730 mA
- High power factor, low THD
- No-load: better than 250 mW @ 230 V_{in}
- Full load efficiency: 90%
- Short circuit protection with auto restart
- Safety: accordance with EN60065
- PCB board: 130 mm x 50 mm single side PCB
- RoHS compliant

Description

The STEVAL-ILL069V2 supplies a stable and insulated 48 V voltage bus suitable for secondary side circuitry (e.g., LED current generators) for a total output power of 35 W when a wide range of input voltages is applied at its input. An auxiliary 16 V output is also present to supply small circuits which absorb a maximum current of 20 mA.

A very high power factor is obtained thanks to the features of the HVLED001A. Input voltage variations, excessive input voltage (surge or burst overvoltage) or very low input voltages are managed by some of the protections of the HVLED001A, improving the reliability of the application.

The efficiency of the application is very high even at very low load thanks to the improved frequency fold-back feature that also reduces the output voltage ripple at light load.

Output short circuit and overload protections are auto-restart for safe operation in lighting environments.

1 Board description

Figure 1: Jumper and connector locations

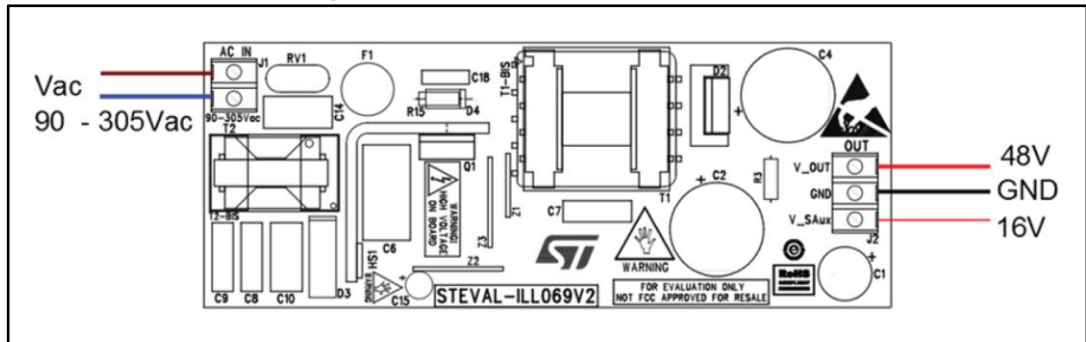

2 Schematic diagram

Figure 2: STEVAL-ILL069V2 circuit schematic

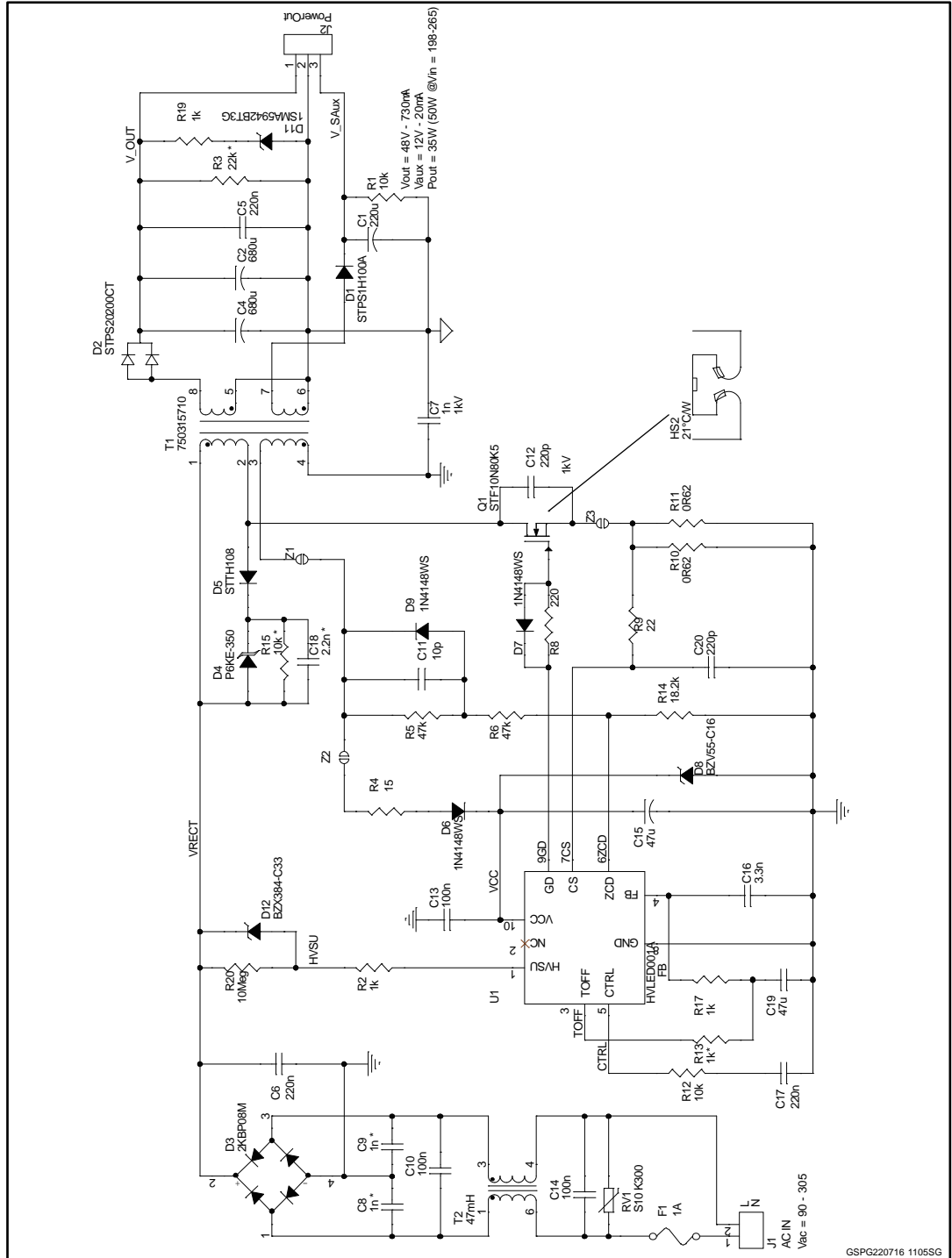

3 Revision history

Table 1: Document revision history

Date	Version	Changes
15-Sep-2016	1	Initial release.