

STLUX385A evaluation board

Data brief

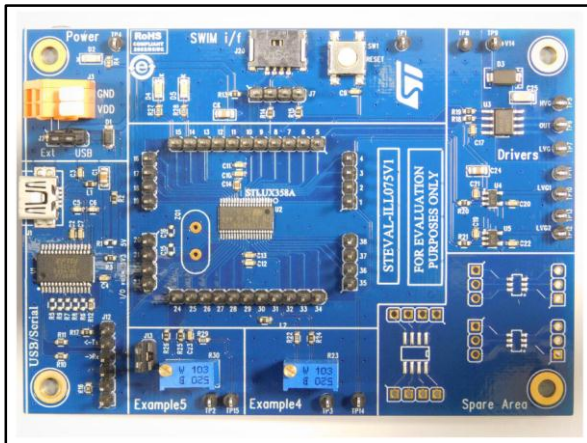

Features

- All STLUX385A pins available on connectors
- Convenient tool for validating SMED algorithms
- Graphical interface for SMED configuration
- On-board components for tutorial
- Micro-USB port for PC connectivity
- USB, external or SWIM power supply
- SWIM interface with STLINK or RLINK connectors
- Four extra footprint areas for SOT23-6 and one for SO8
- One external clock (HSE) footprint area
- RoHS compliant

Description

The STEVAL-ILL075V1 evaluation board is designed to help familiarize the user with the STLUX family of digital controllers and their innovative SMED (state machine, event driven) architecture. A convenient GUI enables the user to quickly generate the optimal SMED configuration for the application.

The external pins make it easy to inject SMED events and capture the SMED controlled PWM clock, thereby helping the user to validate the SMED configuration. Alternatively, the application circuit can be driven directly from the evaluation board.

The board provides a micro-USB connector to allow programming, GUI connectivity and configuration via a terminal utility running on a PC.

STLUX controllers integrate a serial interface which can be used to extend the STLUX communication capabilities via Bluetooth, WiFi or powerline modems.

The STEVAL-ILL075V1 evaluation board can be powered in three different ways: by external power supply, USB or via the SWIM interface.

The board features several free footprint areas which are ideal for connecting power drivers or amplifiers.

An additional free PCB footprint allows the user connect a quartz clock, which can be used in place of the STLUX385A internal clock.

1 Board description

Table 1: STEVAL-ILL075V1 electrical specifications

Parameter	Value
J3, Voltage	3.0 V min. to 5.5 V max
J3, Current	100 mA
J1, Voltage	5 V typ.
J1, Current	100 mA

The user must close the appropriate jumper to select the correct power supply.

Table 2: STEVAL-ILL075V1 power input selection

Parameter	Value
J2-EXT	External power supply via J3 (VDD)
J2-USB	Power supply via USB cable (J1) - default

Table 3: STLUX385A pin-out

Pin number	Connector	Type	Pin name	Main function	Alternative function 1	Alternative function 2	Alternative function 3
1	PIN1	I/O	GPIO1[0]/PWM[0]	SMED PWM channel 0	General purpose I/O 10	-	-
2	PIN2	I/O	DIGIN[0]/CCO_clk	Digital input 0	Configurable clock output signal (CCO)	-	-
3	PIN3	I	DIGIN[1]	Digital input 1	-	-	-
4	PIN4	I/O	GPIO1[1]/PWM[1]	SMED PWM channel 1	General purpose I/O 11	-	-
5	PIN5	I/O	GPIO1[2]/PWM[2]	SMED PWM channel 2	General purpose I/O 12	-	-
6	PIN6	I	DIGIN[2]	Digital input 2	-	-	-
7	PIN7	I	DIGIN[3]	Digital input 3	-	-	-
8	PIN8	I/O	GPIO1[5]/PWM[5]	SMED PWM channel 5	General purpose I/O 15	-	-
9	PIN9	I/O	SWIM	SWIM data interface	-	-	-
10	PIN10	I/O	NRST	Reset	-	-	-

Pin number	Connector	Type	Pin name	Main function	Alternative function 1	Alternative function 2	Alternative function 3
11	PIN11	PS	VDD	Digital and I/O power supply	-	-	-
12	PIN12	PS	VSS	Digital and I/O ground	-	-	-
13	PIN13	PS	VOOUT	1.8 V regulator capacitor	-	-	-
14	PIN14	I/O	GPIO0[4]/Dali_tx/ I2C_sda/Uart_TX	General purpose I/O 04	DALI data transmit	I2C data	UART data transmit
15	PIN15	I/O	GPIO0[5]/Dali_rx/ I2C_scl/Uart_RX	General purpose I/O 05	DALI data receive	I2C clock	UART data receive
16	PIN16	I/O	GPIO1[4]/PWM[4]	SMED PWM channel 4	General purpose I/O 14	-	-
17	PIN17	I	DIGIN[4]/I2C_sda	Digital input 4	I2C data	-	-
18	PIN18	I	DIGIN[5]/I2C_scl	Digital input 5	I2C clock	-	-
19	PIN19	I/O	GPIO1[3]/PWM[3]	SMED PWM channel 3	General purpose I/O 13	-	-
20	PIN20	I/O	GPIO0[2]/I2C_sda / HseOscout/Uart_tx	General purpose I/O 02	I2C data	output crystal oscillator signal	UART data transmit
21	PIN21	I/O	GPIO0[3]/I2C_scl/ HseOscin/Uart_rx	General purpose I/O 03	I2C clock	Input crystal oscillator signal /input clock signal	UART data receive
22	PIN22	I/O	GPIO0[0]/Uart_tx/ I2C_sda	General purpose I/O 00	UART data transmit	I2C data	-
23	PIN23	I/O	GPIO0[1]/Uart_rx/ I2C_scl	General purpose I/O 01	UART data receive	I2C clock	-
24	PIN24	I	CPP[3]	Positive analog comparator input 3	-	-	-
25	PIN25	I	CPP[2]	Positive analog comparator input 2	-	-	-
26	PIN26	I	CPM3	Negative analog comparator input 3	-	-	-

Pin number	Connector	Type	Pin name	Main function	Alternative function 1	Alternative function 2	Alternative function 3
27	PIN27	I	CPP[1]	Positive analog comparator input 1	-	-	-
28	PIN28	I	CPP[0]	Positive analog comparator input 0	-	-	-
29	PIN29	PS	VDDA	Analog power supply	-	-	-
30	PIN30	PS	VSSA	Analog ground	-	-	-
31	PIN31	I	ADCIN[7]	Analog input 7	-	-	-
32	PIN32	I	ADCIN[6]	Analog input 6	-	-	-
33	PIN33	I	ADCIN[5]	Analog input 5	-	-	-
34	PIN34	I	ADCIN[4]	Analog input 4	-	-	-
35	PIN35	I	ADCIN[3]	Analog input 3	-	-	-
36	PIN36	I	ADCIN[2]	Analog input 2	-	-	-
37	PIN37	I	ADCIN[1]	Analog input 1	-	-	-
38	PIN38	I	ADCIN[0]	Analog input 0	-	-	-

Table 4: Connector J3 pinout

Name	Type	Function
VDD	Positive power	Power the board if J2-EXT is closed
GND	Negative power	Directly connected to GND

Table 5: Connector J1 pinout

Name	Type	Function
1	USB-VCC	Power supply
2	USB-DM	USB signal
3	USB-DP	USB signal
4	Not connected	
5	GND	Directly connected to GND

Table 6: Connector J7 - J20 pinout

Name	Type	Function
1	VCC_SWIM	SWIM power sensing
2	SWIM	SWIM signal to/from STLUX
3	GND_SWIM	Directly connected to GND
4	RESn	Connected to STLUX NRST pin

2 Schematic diagrams

Figure 1: STEVAL-ILL075V1 circuit schematic (1 of 5)

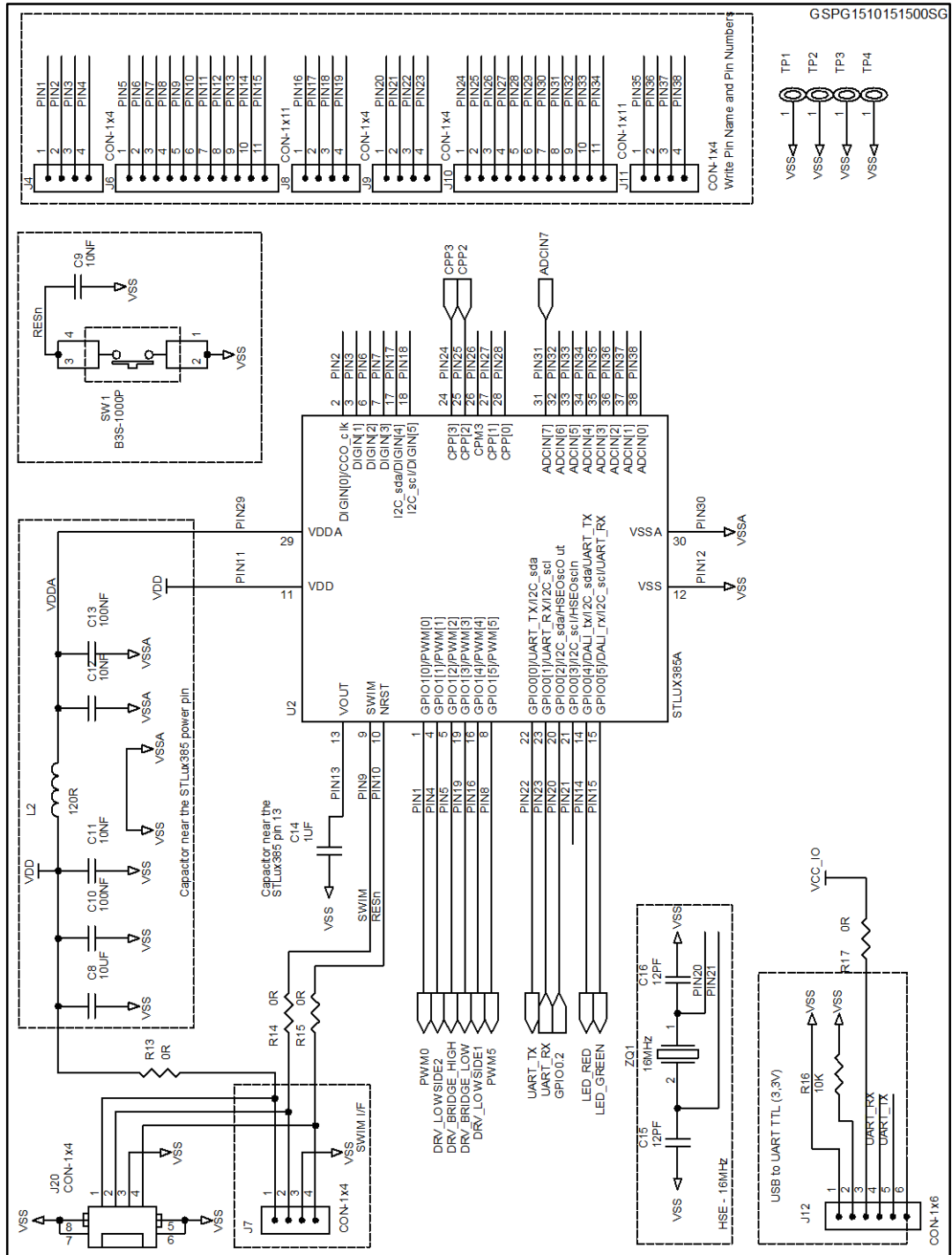

Figure 2: STEVAL-ILL075V1 circuit schematic (2 of 5)

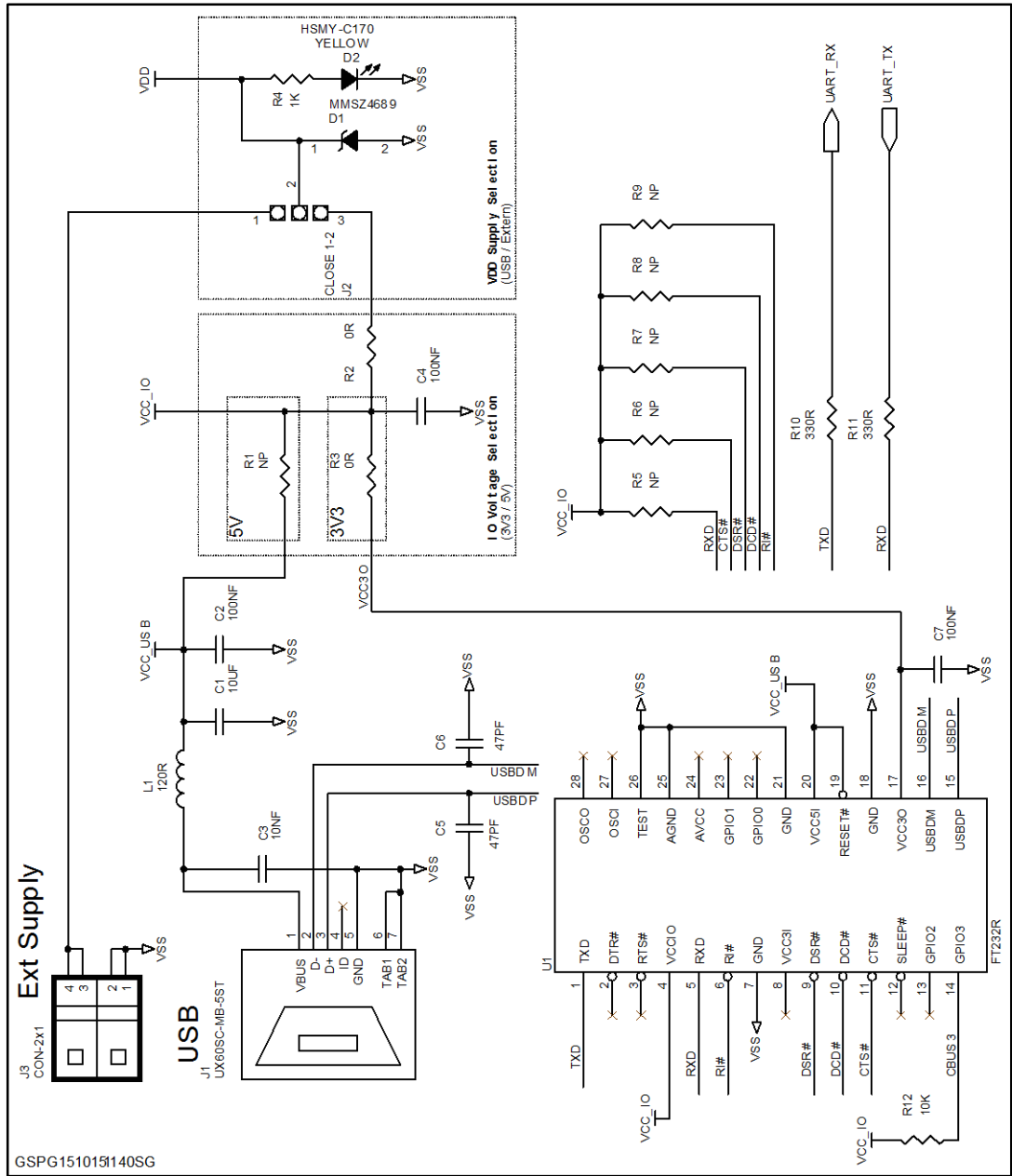

Figure 3: STEVAL-ILL075V1 circuit schematic (3 of 5)

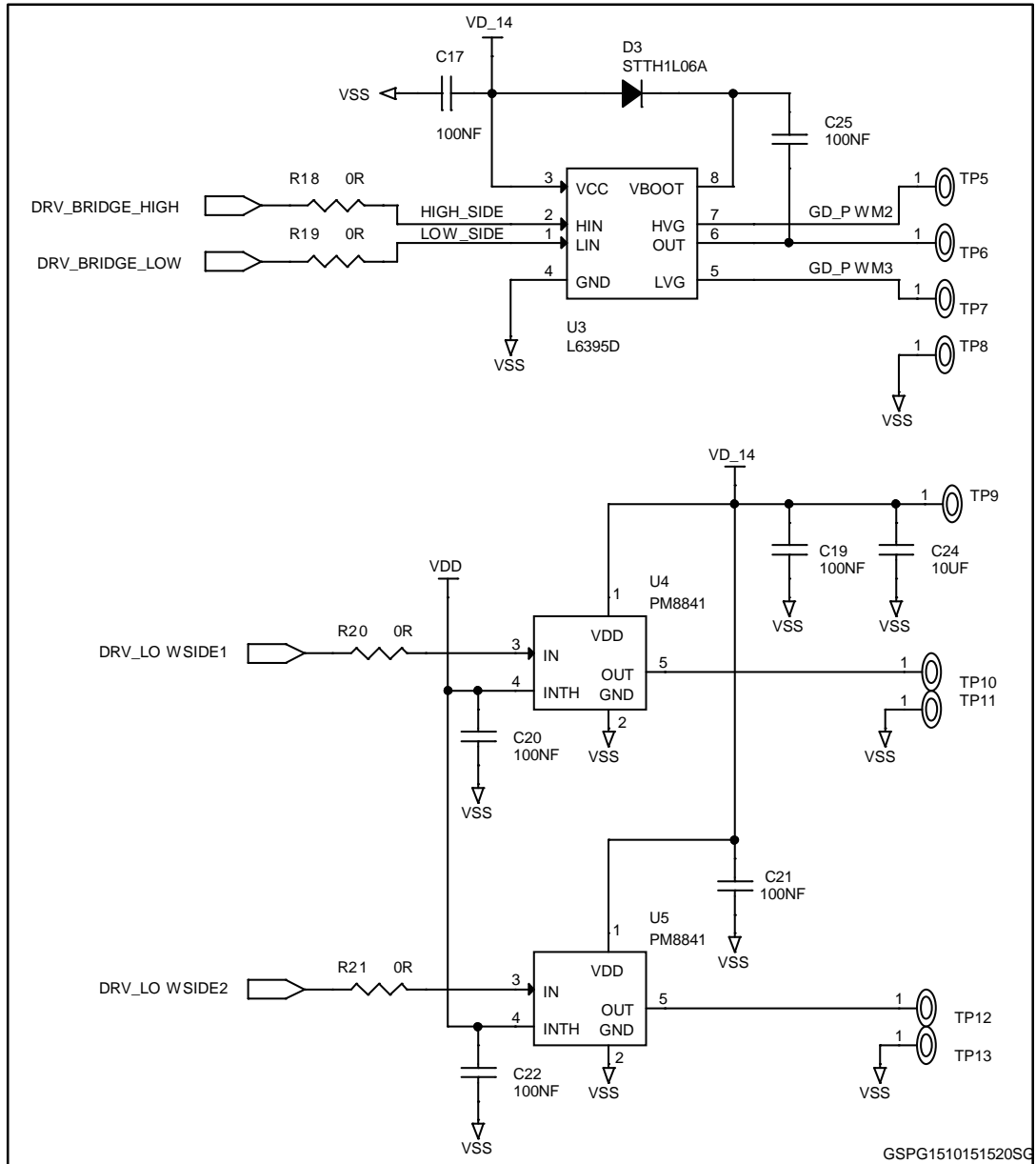

Figure 4: STEVAL-ILL075V1 circuit schematic (4 of 5)

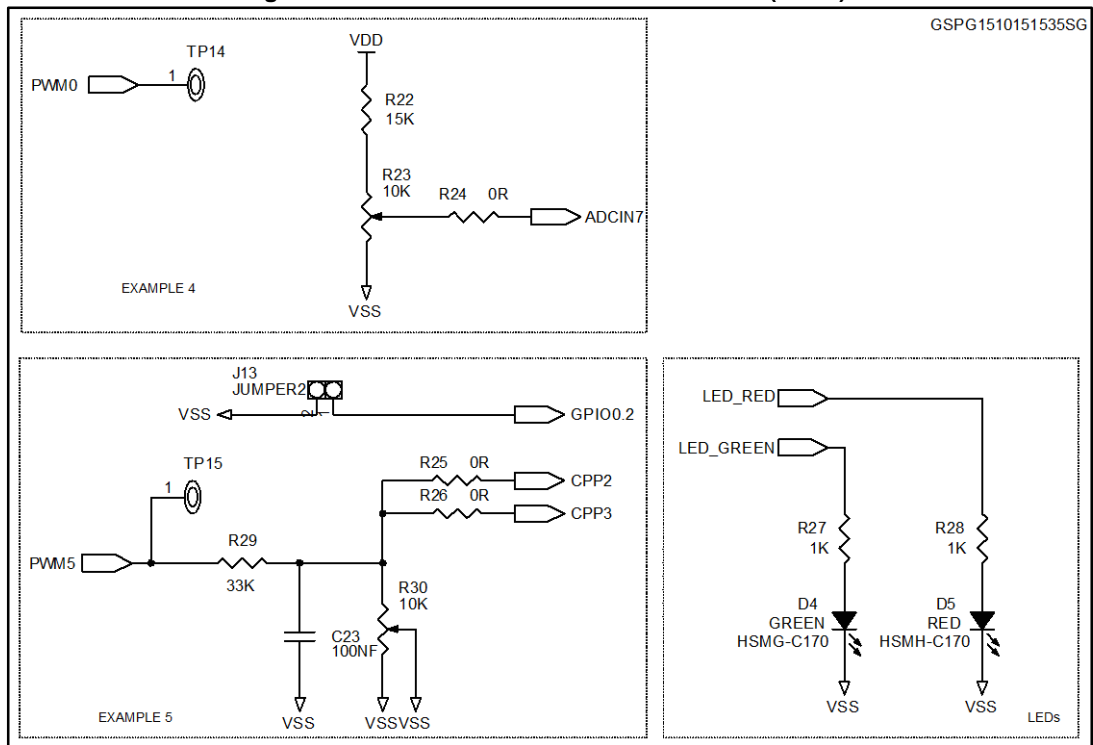

Figure 5: STEVAL-ILL075V1 circuit schematic (5 of 5)

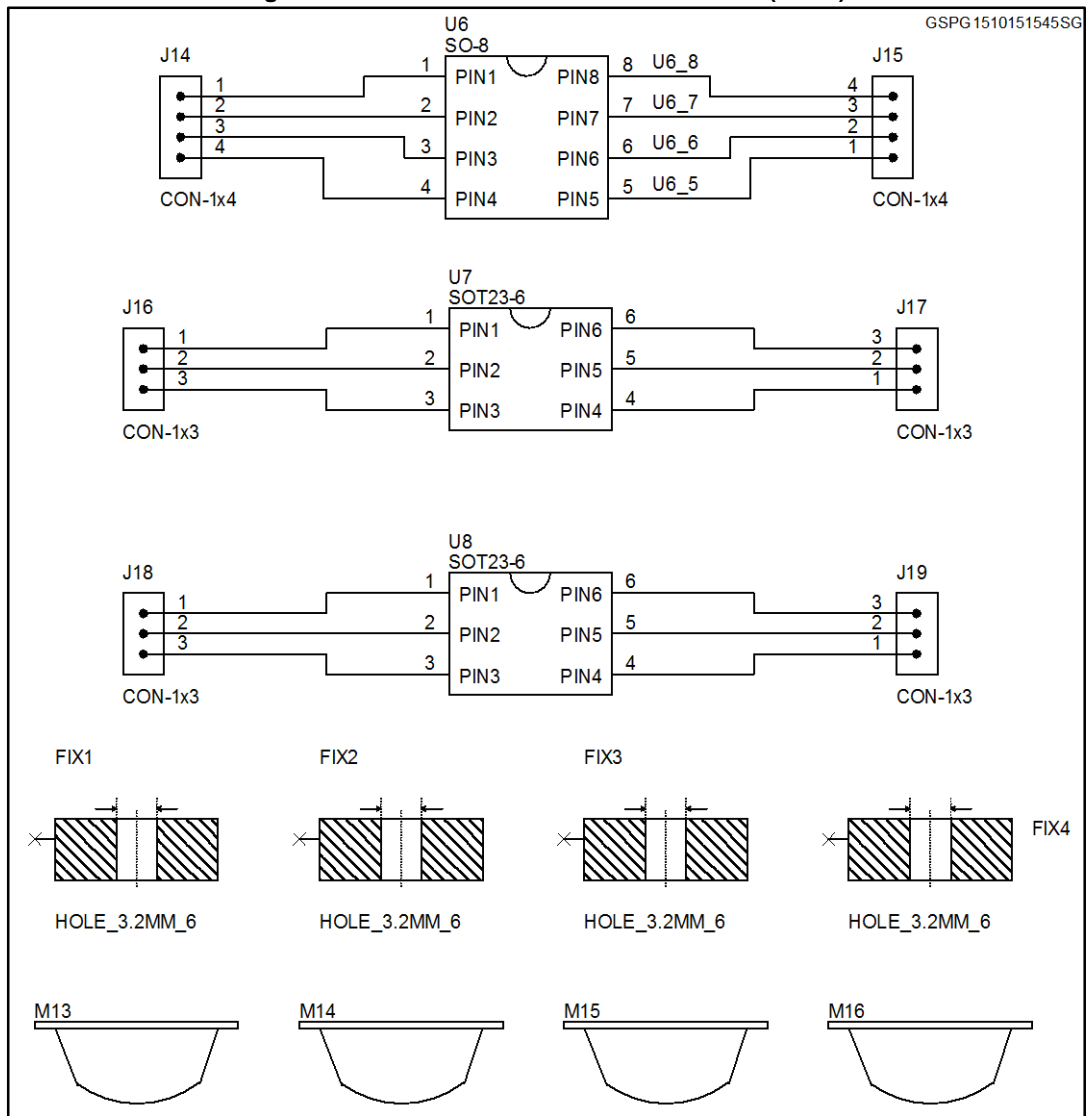

Table 7: STEVAL-ILL075V1 - Bill of material

Reference	Part / Value	Type / Technology information	Package
C1 C8 C24	10 μ F	CAP CER 10 μ F 10V X7R 0805	0805
C2 C4 C7 C10 C13 C17 C19 C20 C21 C22 C23	100 nF	CAP CER 100 nF 50V X7R 0603	0603
C3 C9 C11 C12	10 nF	CAP CER 10 nF 50V X7R 0603	0603
C5 C6	47 pF	CAP CER 47 pF 25V X5R 0603	0603
C14	1 μ F	CAP CER 1 μ F 25V X7R 0603	0603
C25	100 nF	CAP CER 100 nF 50 V +/-5% 1206	1206
D1	MMSZ4689	ZENER 5.1V 0.5W SOD123	SOD-123
D2	YELLOW	LED Yellow - 0805	LED-0805

Reference	Part / Value	Type / Technology information	Package
D3	STTH1L06A	600V Turbo 2 Ultrafast high voltage rectifier	SMA
D4	GREEN	LED Green - 0805	LED-0805
D5	RED	LED Red - 0805	LED-0805
J1	UX60SC-MB-5ST	CONN Mini USB2.0 SMT	UX60SC-MB-5ST
J2	CLOSE 1-2	JUMP254P-M-3	22-28-4033
J3	CON-2x1	Cage clamp connector, 2 pin	233-502
J4 J7 J8 J9 J11 J14 J15	CON-1x4	Through-hole-1x4-Pin height 10.92 Body 5.8 mm - pitch 2.54 mm	1x4 - pitch 2.54
J6 J10	CON-1x11	Through-hole-1x11-Pin height 10.92 Body 5.8 mm - pitch 2.54 mm	1x11 - pitch 2.54
J12	CON-1x6	Through-hole-1x6-Pin height 10.92 Body 5.8 mm - pitch 2.54 mm	1x6 - pitch 2.54
J13	JUMPER2	STRIP254P-M-2	22-28-4023
J16 J17 J18 J19	CON-1x3	Through-hole-1x3-Pin height 10.92 Body 5.8 mm - pitch 2.54 mm	1x3 - pitch 2.54
J20	CON-1x4	Conn 4 way, 1.27 mm used by Resonance Debugged, SIDE access	ERNI_214012
L1 L2	120 R	Ferrite bead, 120 ohm/500 mA, 0603, WE-CBF series	0603
R2 R3 R13 R14 R15 R17 R18 R19 R20 R21 R24 R25 R26	0 R	RES 0 ohm 5% 1/10W 0603	0603
R4 R27 R28	1 K	RES 1K ohm 5% 1/10W 0603 SMD	0603
R10 R11	330 R	330R ohm 5% 1/10W	0603
R12 R16	10 K	RES 10K ohm 5% 1/10W 0603 SMD	0603
R22 R29	33 K	33K ohm 5% 1/10W	0603
R23 R30	10 K	Trimmer 10 kohm MultiTurn / size 9.6x5x10mm / leaded / top Adjustment	LEADED
SW1	B3S-1000P	SMT tactile switch	B3S-1000P
U1	FT232R	UART over USB bridge, SSOP28	SSOP-28
U2	STLUX385A	Digital controller	TSSOP38_0_5mm
U3	L6395D	High-voltage high and low side driver 600 V SO-8	SO-8

Reference	Part / Value	Type / Technology information	Package
U4 U5	PM8841	High-voltage high and low side driver 600 V SOT23-5	SOT23-5
U6	SO-8	SO-8 PCF footprint provision	SO-8
U7 U8	SOT23-6	SOT23-6 PCF footprint provision	SOT23-6

Figure 6: STEVAL-ILL075V1 layout (top layer)

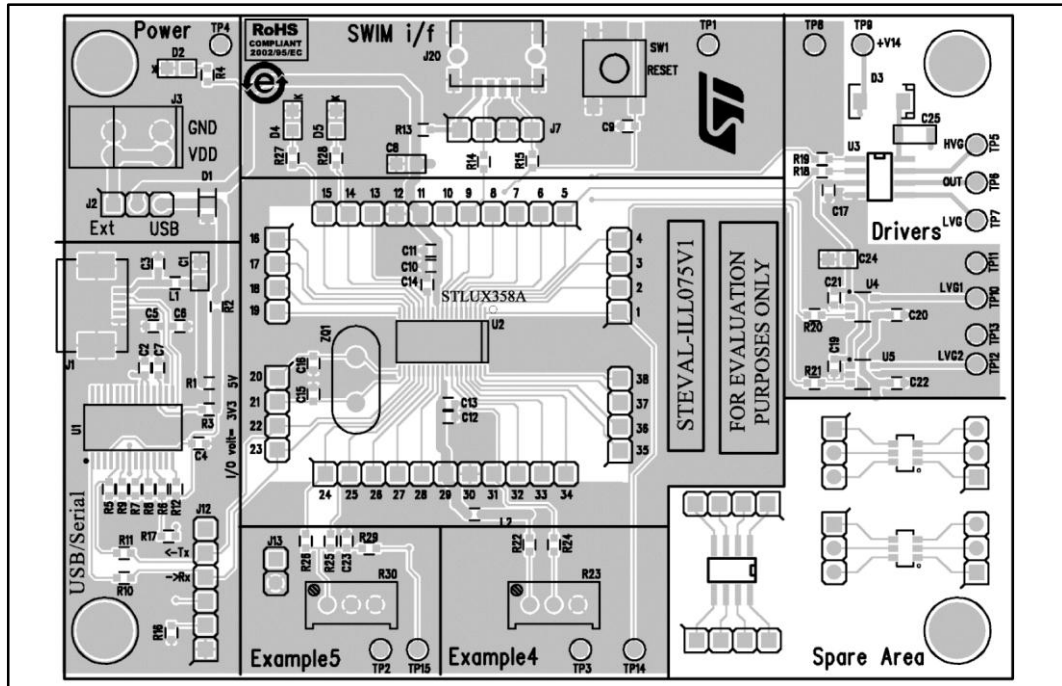

3 Revision history

Table 8: Document revision history

Date	Version	Changes
29-Oct-2015	1	Initial release.