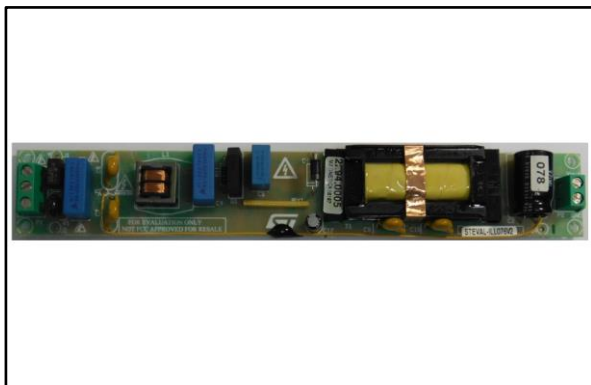

18 W wide input range ultra slim flyback converter using HVLED001A quasi resonant flyback controller and STD8N80K5

Data brief

**Features**

- Input voltage: V_{in} : 90 – 264 Vrms, f: 45 – 66 Hz
- Output power:
 - 18 W at wide input range
 - 40 W at European input range
- Output voltage: 56 V \pm 5 %
- High power factor, low THD
- No-load: better than 400 mW at 230 V_{in}
- Full load efficiency: greater than 92 %
- Short circuit protection with auto restart
- EMI: pre-compliant with EN55022 (B) limits
- Safety: complies with EN60950
- Dimensions: 183 mm x 28 mm x 17 mm
- PCB: single sided, 35 μ m, FR4, mixed PTH/SMD
- RoHS compliant

Description

This board implements an offline power converter based on a single stage high-PF flyback topology using the HVLED001A controller.

A very slim form factor is achieved with innovative magnetic componentry.

The output voltage is controlled by the primary side, thus reducing the need for costly opto-couplers. The HVLED001A PSR precision and the innovative structure of the transformer makes for highly accurate output voltage regulation against load and line changes.

A very high efficiency is obtained and a full set of protections including output short circuit and input overvoltage is included.

Conducted EMI is pre-screened and clearances and creepage distances adhere to EN60950 safety requirements.

Power factor and THD are optimized to be respectively higher than 0.95 and lower than 10% at full load over the entire input voltage range.

The main application for this converter is for bus power supplies in a LED string driver providing 4 kV isolation.

1 Schematic diagram and bill of materials

Figure 1: STEVAL-ILL076V2 circuit schematic

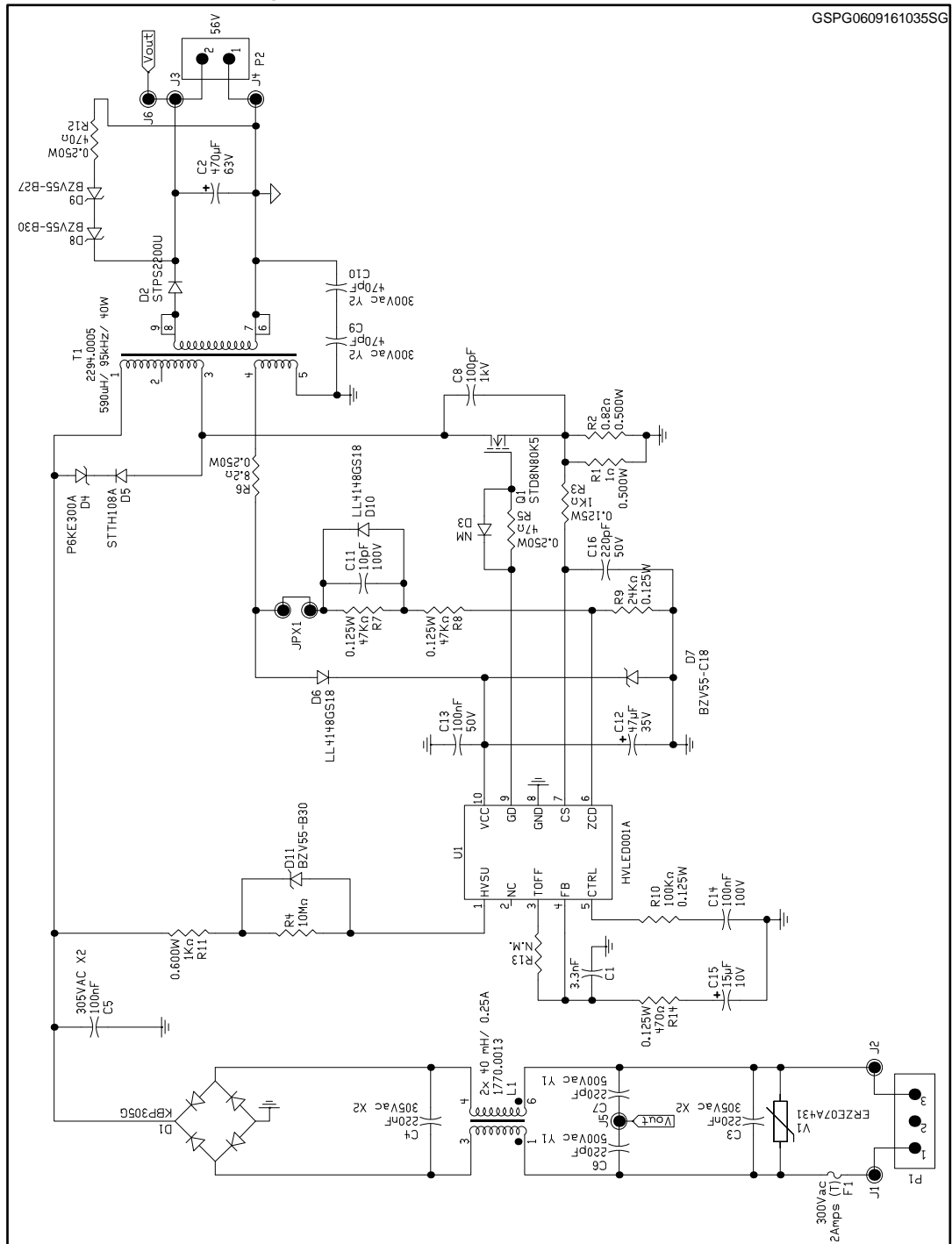

Table 1: Board bill of materials

Q.ty	Reference	Part / Value	Voltage / Watt / Ampere	Tolerance
1	C1	3.3 nF	50 V	10%
1	C2	470 µF	63 V	10%
2	C3, C4	220 nF	305 Vac X2	10%
1	C5	100 nF	305 Vac X2	10%
2	C6, C7	220 pF	500 Vac Y1	10%
1	C8	100 pF	1 kV	10%
2	C9, C10	470 pF	300 Vac Y2	10%
1	C11	10 pF	100 V	10%
1	C12	47 µF	35 V	10%
2	C13, C14	100 nF	100 V	10%
1	C15	15 µF	10 V	10%
1	C16	220 pF	50 V	10%
1	D1	KBP305G	600 V / 3 A	
1	D2	STPS2200U	200 V / 2 A	
0	D3	NM		
1	D4	P6KE300A	300 V	
1	D5	STTH108A	800 V / 1 A	
2	D6, D10	LL4148GS18		
1	D7	BZV55-C18	Zener 18 V	
2	D8, D11	BZV55-B30	Zener 30 V	
1	D9	BZV55-B27	Zener 27 V	
1	F1	2 Amps (T)	300 Vac	
1	JPX1		20.5 mm	
1	JPX2		171 mm TIW	
1	L1	1770.0013	2x 40 mH/ 0.25 A	
1	P1	SIP header		
1	P2	SIP header		
1	Q1	STD8N80K5	800 V / 8 A	
1	R1	1 ohms	0.500 W	1%
1	R2	0.82 ohms	0.500 W	1%
1	R3	1 Kohms	0.125 W	1%
1	R4	10 Mohms	0.125 W	1%
1	R5	47 ohms	0.250 W	1%
1	R6	8.2 ohms	0.250 W	1%
1	R7, R8	47 Kohms	0.125 W	1%

Q.ty	Reference	Part / Value	Voltage / Watt / Ampere	Tolerance
1	R9	24 Kohms	0.125 W	1%
1	R10	100 Kohms	0.125 W	1%
1	R11	1 Kohms	0.600 W	1%
1	R12	470 ohms	0.250 W	1%
1	R13	N.M.		
1	R14	470 ohms	0.125 W	1%
1	T1	2294.0005	590 μ H/ 95k Hz/ 40 W	
1	U1	HVLED001A		
1	V1	ERZE07A431	MOV	

3 Revision history

Table 2: Document revision history

Date	Version	Changes
13-Sep-2016	1	Initial release.