

18 W tube replacement zero ripple LED driver using HVLED001A quasi resonant flyback controller and STF10LN80K5

Data brief

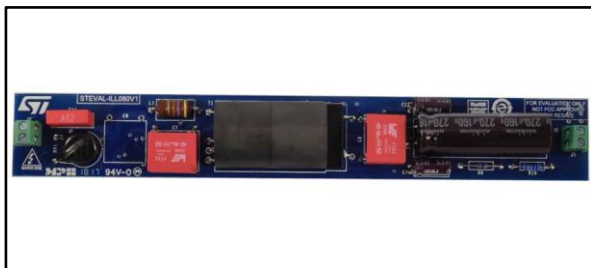

Features

- Input voltage: $V_{in} = 180 - 264$ Vrms, $f = 45 - 66$ Hz
- Output current: 200 mA
- 100 Hz output current ripple: $< 1\%$
- LED string voltage: $83\text{ V} \pm 10\%$
- No load output voltage: 110 V
- High power factor, low THD
- No-load: better than 300 mW at 230 V_{in}
- Full load efficiency: $> 85\%$
- Short circuit protection with auto restart
- RoHS compliant

Description

The STEVAL-ILL080V1 provides a 200 mA, ripple-free output current to supply a single LED string between 75 and 93 V.

The form factor and specific component selection render this board suitable for rounded enclosures, as replacements for fluorescent lamp tubes (T8 size).

As typical applications are totally sealed, non isolated, high power factor SEPIC topology is used to achieve a high power factor, low THD ($< 20\%$) and very high efficiency, as well as allowing input current ripple steering, which dramatically reduces EMI, even with small input filters.

The HVLED001A controller protections manage input voltage variations, excessive input voltage (overvoltage like surge or bursts) and very low input voltages.

The efficiency of the application is very high, compared with similar wattage applications.

1 Board description

Figure 1: Jumpers and connectors location

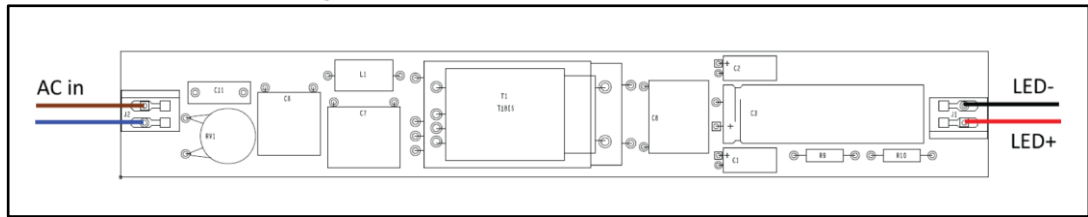
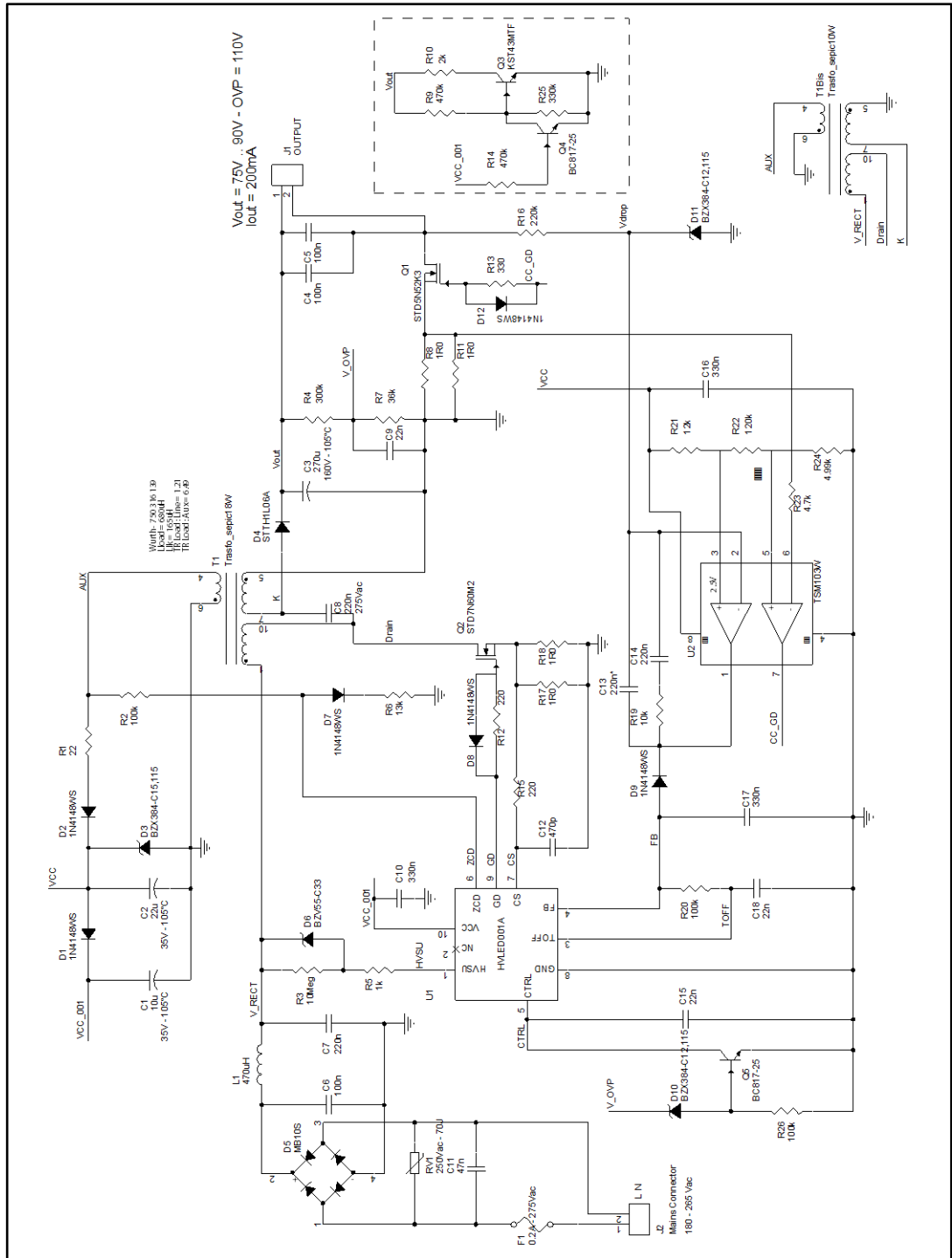

Figure 2: STEVAL-ILL080V1 circuit schematic



2 Revision history

Table 1: Document revision history

Date	Version	Changes
04-Aug-2017	1	Initial release.