

1 A buck LED driver board based on the ALED6000 automotive-grade dimmable LED driver



Features

- 4.5 V to 60 V input voltage
- Step-down conversion
- 1 A programmed LED current
- 500 kHz switching frequency
- Digital dimming
- Compliant with ceramic output capacitors
- 180° out of phase synchronization available
- Auto recovery overcurrent and thermal protection
- RoHS and WEEE compliant

Description

The [STEVAL-ILL089V1](#) evaluation board is based on the [ALED6000](#) monolithic current source for high power LED driving. Digital dimming is implemented by driving the dedicated DIM pin. Low drop-out operation with almost 100% duty cycle can be achieved.

The ALED6000 is a 61 V asynchronous switching regulator with embedded Power MOSFET, designed to source up to 3 A_{DC} current depending on the application conditions. The 250 mV typical R_{SENSE} voltage drop, the embedded switchover feature on the VBIAS pin and the light load management (pulse skipping) all contribute to maximizing power conversion efficiency across the entire load range.

The current limit threshold and the switching frequency are adjustable for application optimization. The device includes an internal 250 kHz oscillator that can be externally adjusted up to 1.5 MHz. The size of the overall application is minimized thanks to the high switching frequency and its compatibility with ceramic output capacitors. Two ALED6000 regulators can be synchronized in a 180° out-of-phase configuration for reduced total input RMS current.

Product summary table	
1 A buck LED driver board based on the ALED6000	STEVAL-ILL089V1
Automotive 3 A, 61 V monolithic current source with dimming capability	ALED6000
Application	Automotive Motor Control

1 Schematic diagram

Figure 1. STEVAL-ILL089V1 board schematic

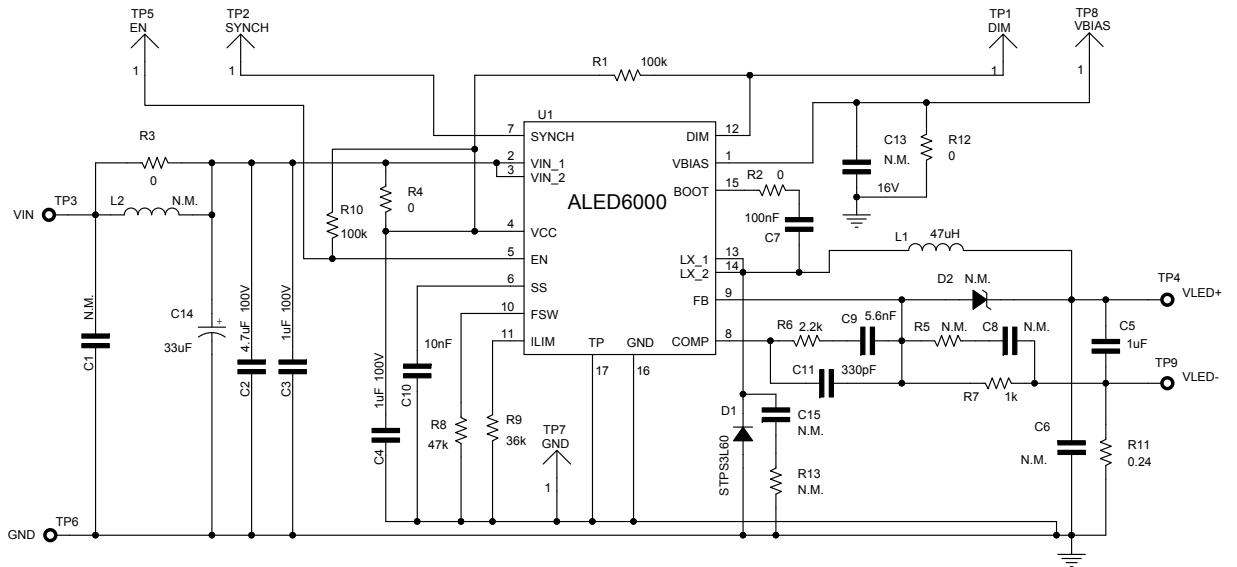

Revision history

Table 1. Document revision history

Date	Version	Changes
07-Nov-2019	1	Initial release.