



STEVAL-ILM001V1

Plug-in hardware module for the STM8S-DISCOVERY interface for DALI communication

Data brief

Features

- Level translation from DALI voltage levels (-6.5 to 22.5 V) to microcontroller levels (3.3 V / 5 V logic)
- Proper rise/fall times for the communication
- Current consumption limit (2 mA max.)
- Overvoltage protection for misconnection of rated mains voltage to DALI DA connectors
- RoHS compliant

Description

The STEVAL-ILM001V1 is a plug-in module for the STM8S-DISCOVERY kit and SW DALI library, to create a fully working DALI slave application. The STM8S-DISCOVERY + STEVAL-ILM001V1 work as a DALI slave device and can be connected to and controlled by any DALI network.

The LD1 on the STM8S-DISCOVERY kit is used as a light source. Its brightness, fade-in/out times, etc., as defined by the DALI standard, can be controlled through DALI to simulate a normal lamp behavior.

The DALI (Digital Addressable Lighting Interface) standard is a communication protocol widely used in intelligent lighting applications. Its use is not limited to fluorescent tube lamp dimmable ballasts, for which it was initially designed, but also for future LED applications.

The user is expected to be familiar with the DALI standard and its details.



1 Circuit schematic

Figure 1. Circuit schematic

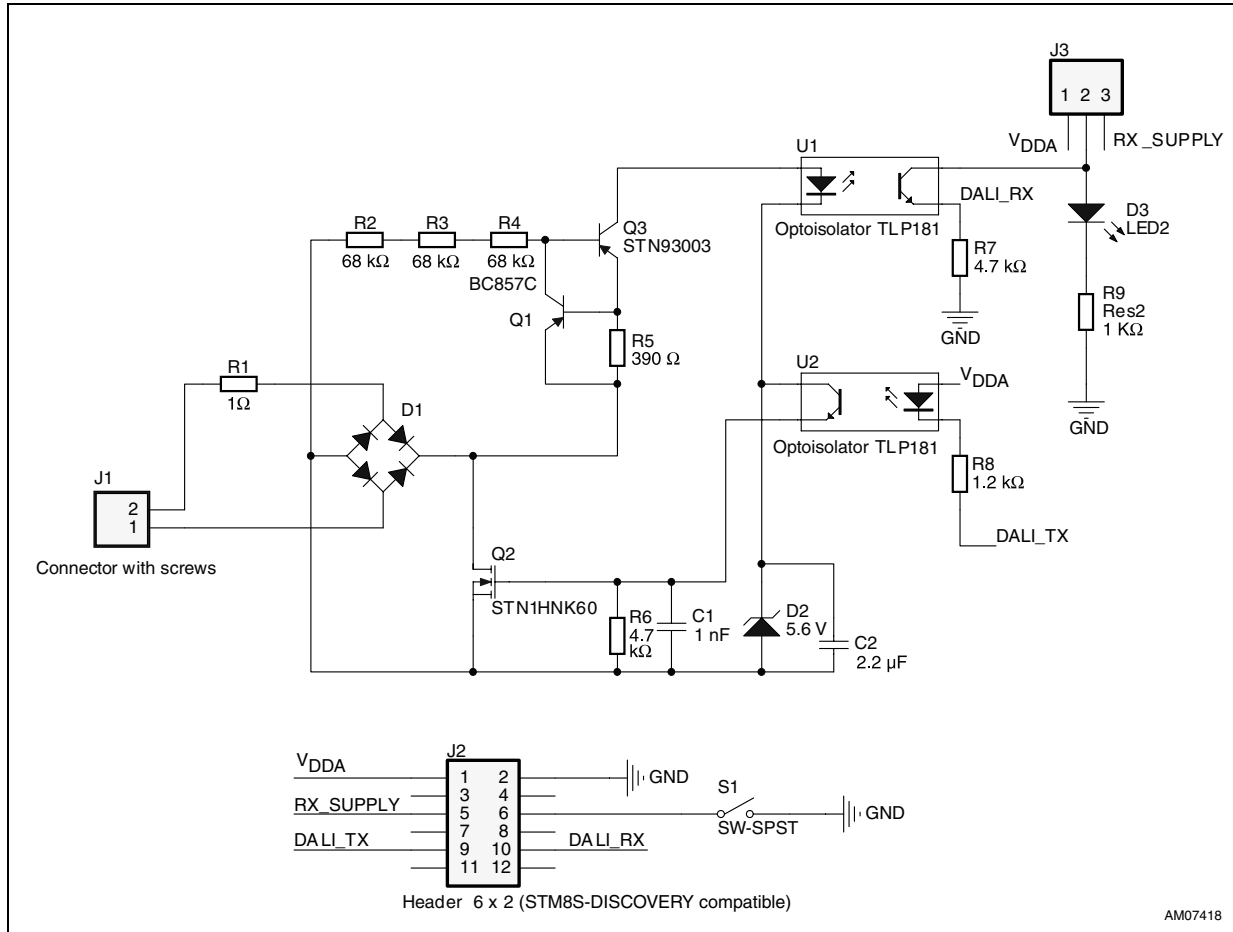

AM07418

2 Revision history

Table 1. Document revision history

Date	Revision	Changes
23-Dec-2010	1	Initial release.