

Industrial smart sensor kit based on L6364W dual IO-Link device transceiver



Features

- Kit content:
 - STEVAL-IOD004V1 (45.8 x 8.3 mm) main board with shape easy to be integrated in industrial sensors housing (not available for separate sale)
 - [STLINK-V3MINI](#) programmer and debugger tool
 - M8-M12 industrial connector adapter including a 20 cm cable
 - 14-pin flat cable
- Main board features:
 - Industrial sensor node based on [STM32G071EB](#) (mainstream Arm® Cortex®-M0+ RISC core MCU operating at up to 64 MHz frequency), [L6364W](#) (dual channel transceiver IC for SIO and IO-Link sensor applications), [IIS2MDC](#) (high accuracy, ultra-low-power, 3-axis digital output magnetometer) and [ISM330DHCX](#) (iNEMO inertial module with machine learning core, and finite state machine with digital output for industrial applications)
 - Runs an IO-Link v.1.1 demo-stack and MEMS control software, included in the companion package [STSW-IOD04K](#) together with the IODD file
 - Operating voltage range 7 to 32 V
 - Four-pole M8 industrial standard connector
 - [L6364W](#) embedded DC-DC converter provides 3.3 V supply for all on-board ICs
 - General-purpose LEDs for transmission, programming/debugging, warning, and status
 - Jumpers for CQ and DIO selection in independent or joint mode
 - Switch for transmission mode selection (transparent, single, or multioctet)
 - Reset button
 - 10-pin connector for sensor expansion options
 - SWD connector for debugging and programming capability
 - Protections against surge pulse (up to ± 3APK with 500 Ω coupling) and reverse polarity
 - EMC and EMI tested according to standard requirements
 - RoHS compliant

Product summary	
Industrial smart sensor kit based on L6364W dual IO-Link device transceiver	STEVAL-IOD04KT1
Software pack for STEVAL-IOD04KT1 with IO-Link stack v1.1, IODD, and control software for industrial sensors	STSW-IOD04K
Dual channel IO-Link device transceiver in CSP package	L6364W
Applications	Factory automation Industrial sensors

Description

The [STEVAL-IOD04KT1](#) is a reference design kit that exploits the features of the [L6364W](#) IO-Link dual-channel device transceiver.

The kit consists of the [STEVAL-IOD004V1](#) main board (not available for sale), the [STLINK-V3MINI](#) programmer and debugger tool, a 14-pin flat cable, and an M8 to M12 standard industrial connector adapter.

The kit acts as a modern smart industrial sensor to be connected to a master IO-Link hub (or a suitable PLC interface).

The power supply for the MCU, sensors, and other logic devices derives from the DC-DC converter controller embedded in the [L6364W](#).

The on-board [STM32G071EB](#) microcontroller runs an IO-Link demo stack v.1.1, which controls the IO-Link communication, and the software code that manages the [L6364W](#) transceiver and the MEMS industrial sensors.

The tiny dimensions of the main board have been achieved thanks to the small sizes of the CSP package options of [L6364W](#) and [STM32G071EB](#).

Connect the main board to an IO-Link master via the adapter and the M8 connector included in the kit for normal operation. Connect the same board to the [STLINK-V3MINI](#) through the flat cable only if you want to program the [STM32G071EB](#) with a new firmware.

1 Solution overview

This reference design targets IO-Link based applications, that is, smart industrial sensors that feature easy configuration, remote monitoring, reduced wiring, advanced diagnostics, and easy device replacement.

The main board (STEVAL-IOD004V1) has been designed with few ICs. Taking this into consideration, smart-sensing applications can benefit from the [L6364W](#) dual-channel transceiver. For example, the [ISM330DHCX](#) inertial module can monitor a robotic arm (for vibration and compensation) while the [IIS2MDC](#) can detect the magnetic field, providing a warning along the supplementary channel.

Figure 1. STEVAL-IOD004V1 functional block diagram

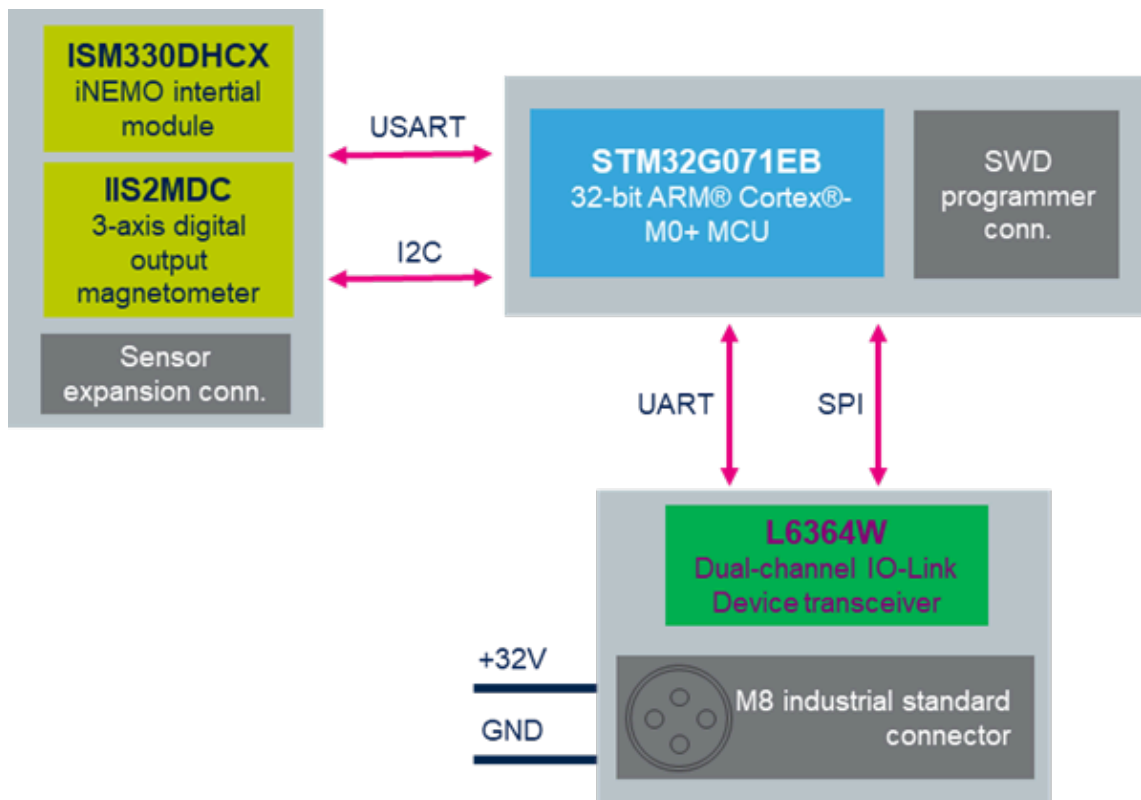

2 Schematic diagrams

Figure 2. STEVAL-IOD004V1 (main board) circuit schematic (1 of 4)

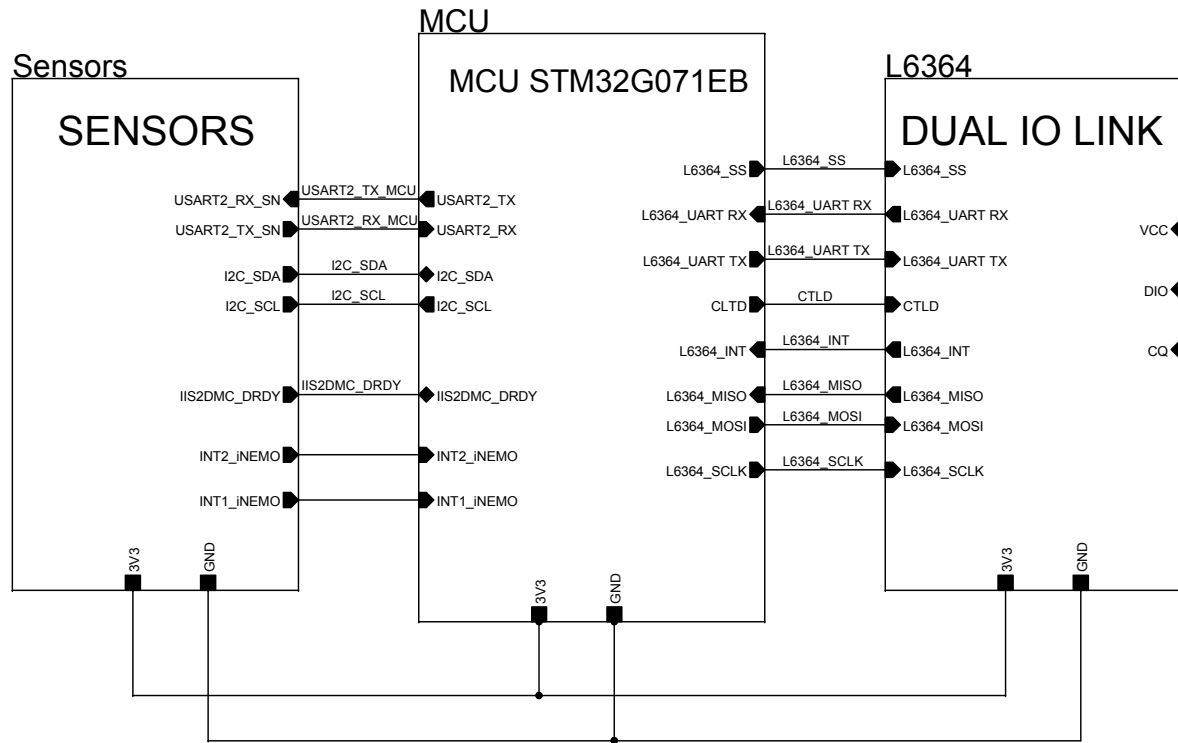

Figure 3. STEVAL-IOD004V1 (main board) circuit schematic (2 of 4)

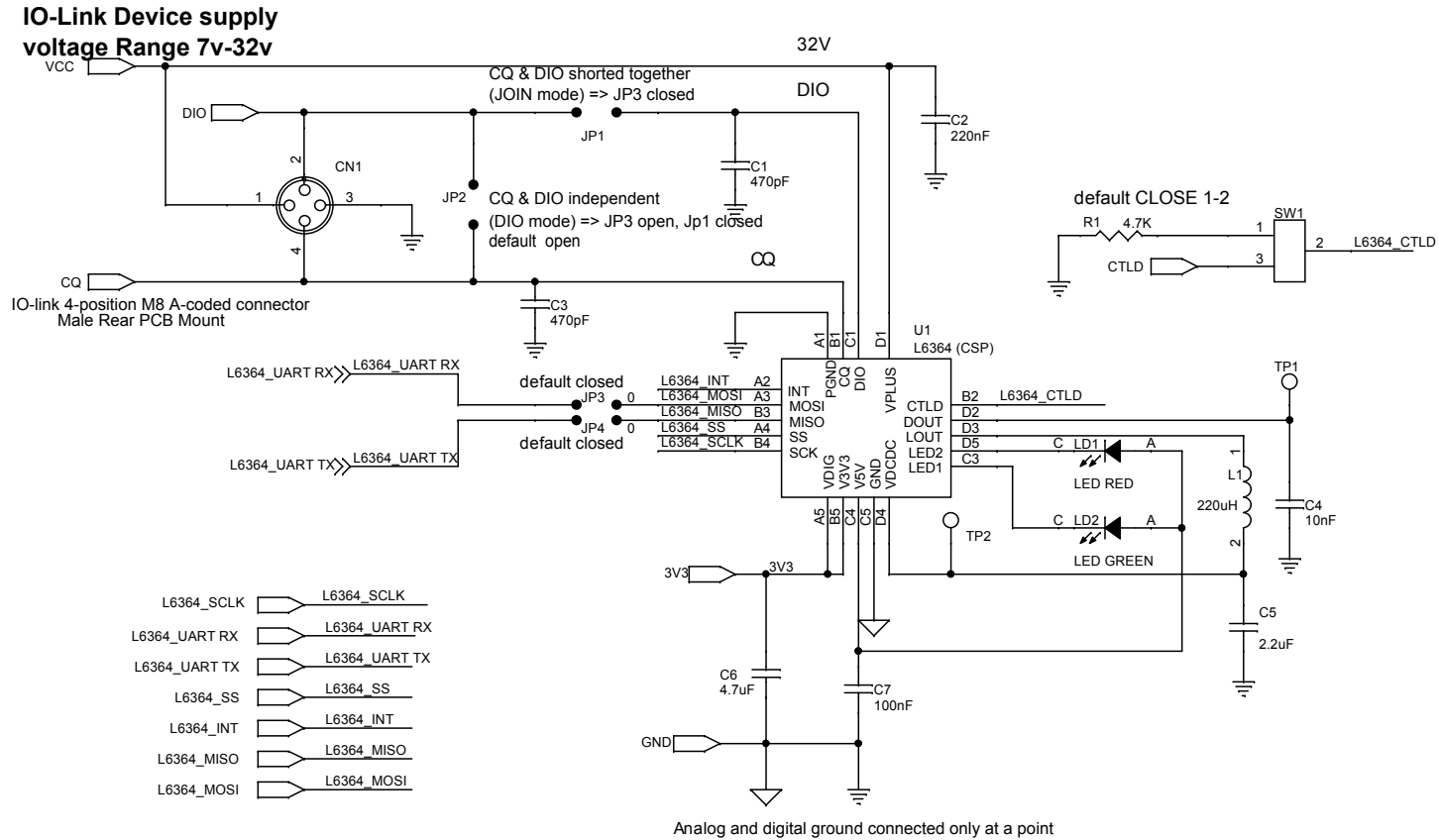

Figure 4. STEVAL-IOD004V1 (main board) circuit schematic (3 of 4)

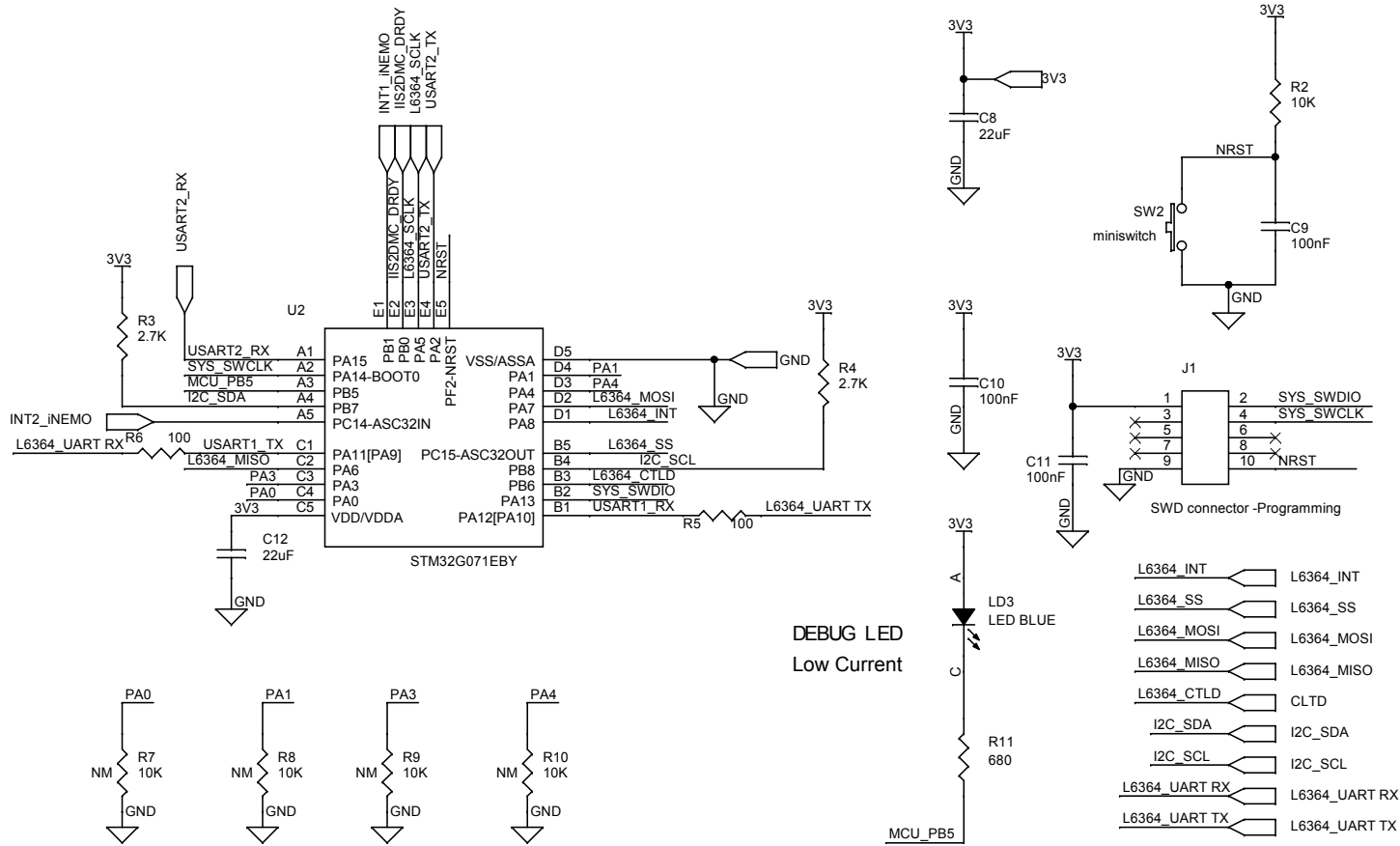
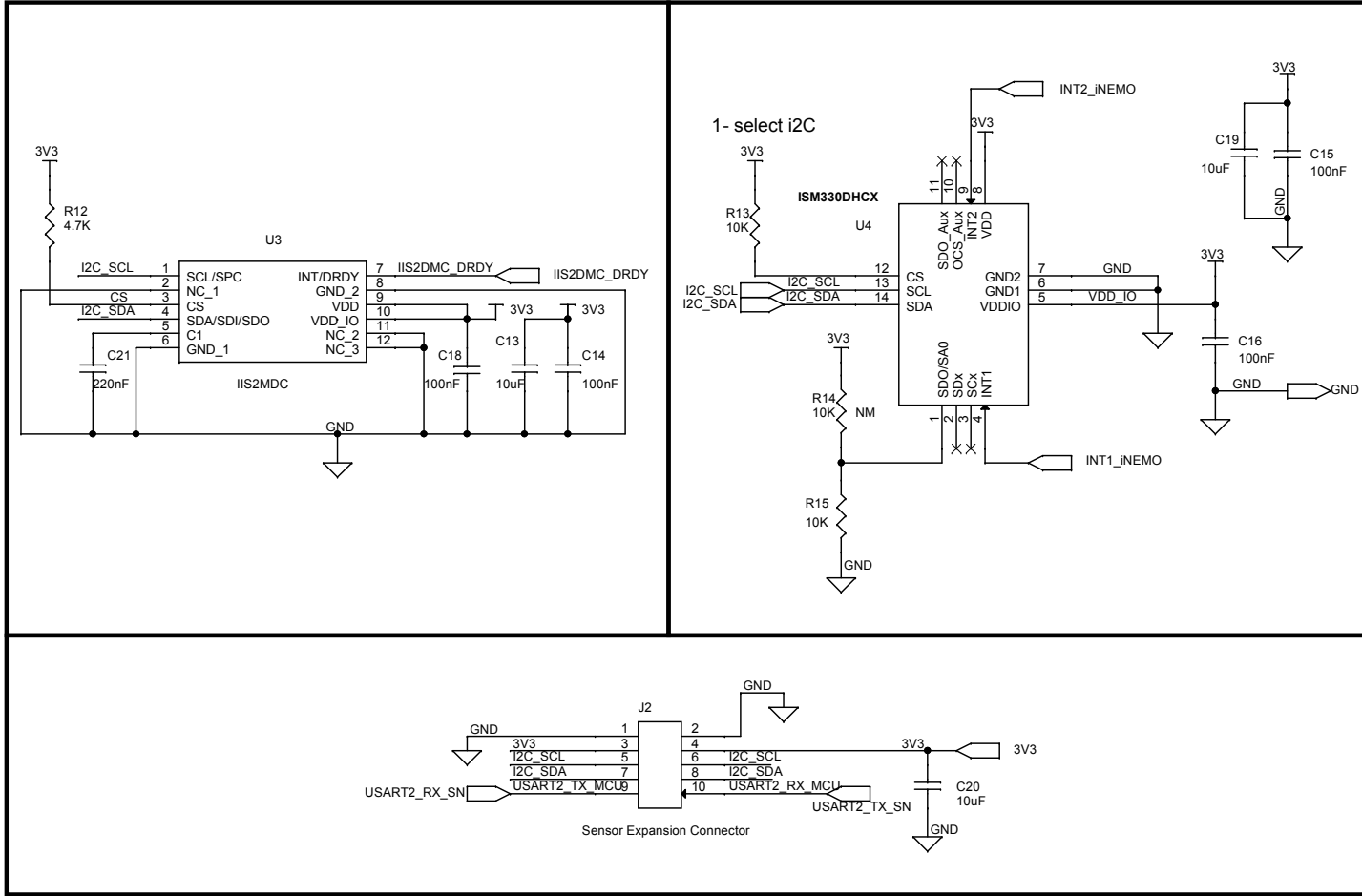

Figure 5. STEVAL-IOD004V1 (main board) circuit schematic (4 of 4)



3 Kit versions

Table 1. STEVAL-IOD04KT1 versions

Finished good	Schematic diagrams	Bill of materials
STEVAL\$IOD04KT1A ⁽¹⁾	STEVAL\$IOD04KT1A schematic diagrams	STEVAL\$IOD04KT1A bill of materials

1. This code identifies the STEVAL-IOD04KT1 evaluation kit first version.

Revision history

Table 2. Document revision history

Date	Revision	Changes
27-Oct-2021	1	Initial release.
13-Dec-2021	2	Updated cover page image.