

# 1500 W motor control power board based on STGIB15CH60TS-L SLLIMM™ 2nd series IPM

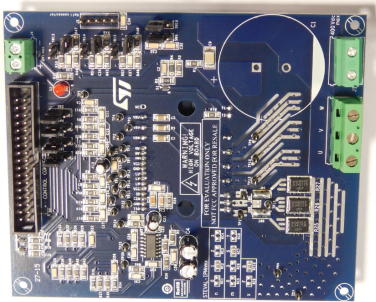

## Features

- Input voltage: 125 - 400 V<sub>DC</sub>
- Nominal power: up to 1500 W
- Nominal current: up to 9 A
- Input auxiliary voltage: up to 20 V DC
- Single- or three-shunt resistors for current sensing (with sensing network)
- Two options for current sensing: dedicated op-amps or through MCU
- Overcurrent hardware protection
- IPM temperature monitoring and protection
- Hall sensor or encoder input
- Uses the STGIB15CH60TS-L IGBT intelligent power module from the 2<sup>nd</sup> series of SLLIMM™ IPMs
- Motor control connector (32-pin) to interface with ST MCU boards
- Universal conception for further evaluation with breadboard and testing pins
- Very compact size

## Description

The **STEVAL-IPM15B** is a compact motor drive power board based on the SLLIMM™ (small low-loss intelligent molded module) 2<sup>nd</sup> series module **STGIB15CH60TS-L**. It provides an affordable, easy-to-use solution for driving high power motors for a wide range of applications such as white goods, air conditioners, compressors, power fans, high-end power tools, and generally 3-phase inverters for motor drives. The IPM itself consists of short-circuit rugged IGBTs and a wide range of features including undervoltage lockout, smart shutdown, temperature sensing and NTC inside, and overcurrent protection. The main characteristics of this evaluation board are its small size, minimal BOM and high efficiency. It consists of an interface circuit (BUS and Vcc connectors), bootstrap capacitors, snubber capacitor, hardware short-circuit protection, fault event signal and temperature monitoring. In order to increase its flexibility, it was designed to work in single or three-shunt configuration and with double current sensing options such as three dedicated op-amps on-board, or op-amps embedded on the MCU. A Hall/Encoder part completes the circuit. Thanks to these advanced characteristics, the system has been specifically designed to achieve accurate and fast conditioning of the current feedback, matching the typical requirements for field-oriented control (FOC). The STEVAL-IPM15B is compatible with ST's STM32-based control board, providing a complete platform for motor control.

Product summary	
STEVAL-IPM15B compact motor drive power board	<a href="#">STEVAL-IPM15B</a>
STGIB15CH60TS-L SLLIMM™ 2nd series IPM	<a href="#">STGIB15CH60TS-L</a>

# 1 Schematic diagrams

Figure 1. STEVAL-IPM15B circuit schematic (1 of 6)

## STEVAL-IPMnmx decoder

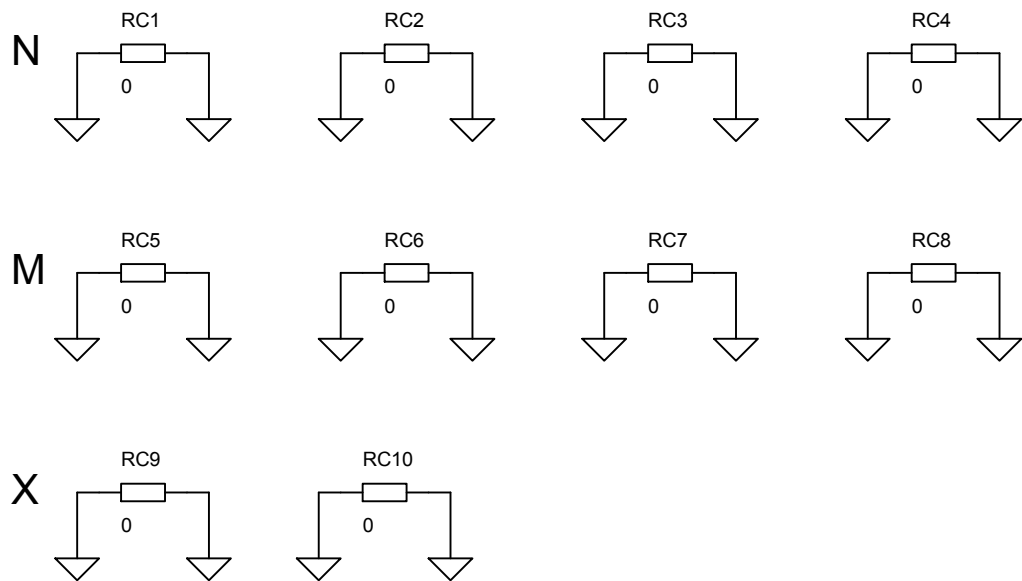

**Figure 2. STEVAL-IPM15B circuit schematic (2 of 6)**

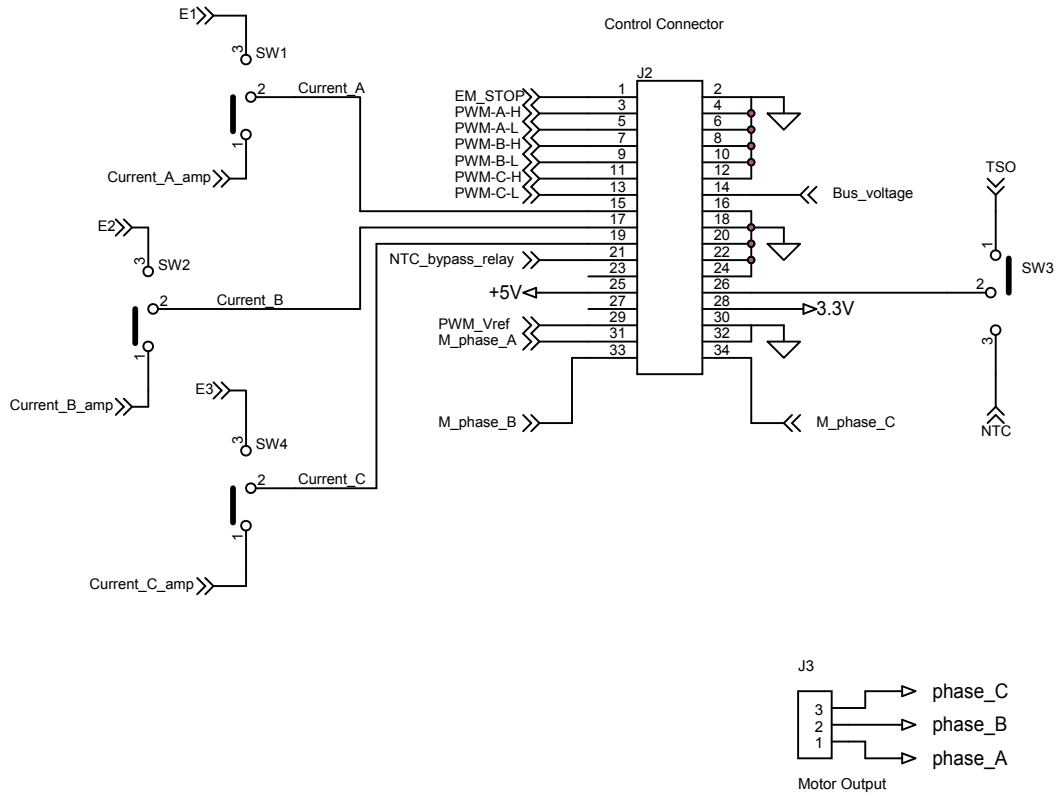

Figure 3. STEVAL-IPM15B circuit schematic (3 of 6)

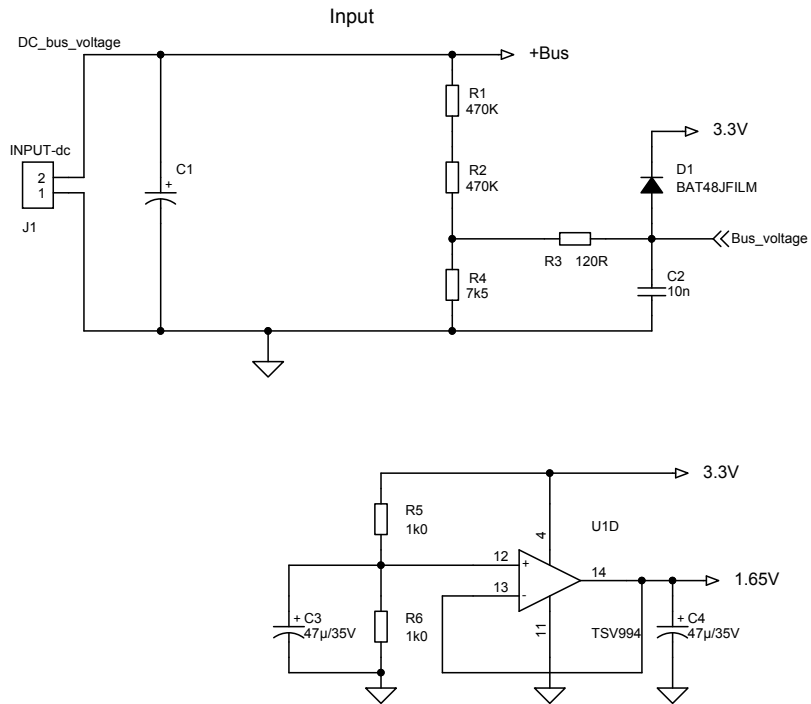
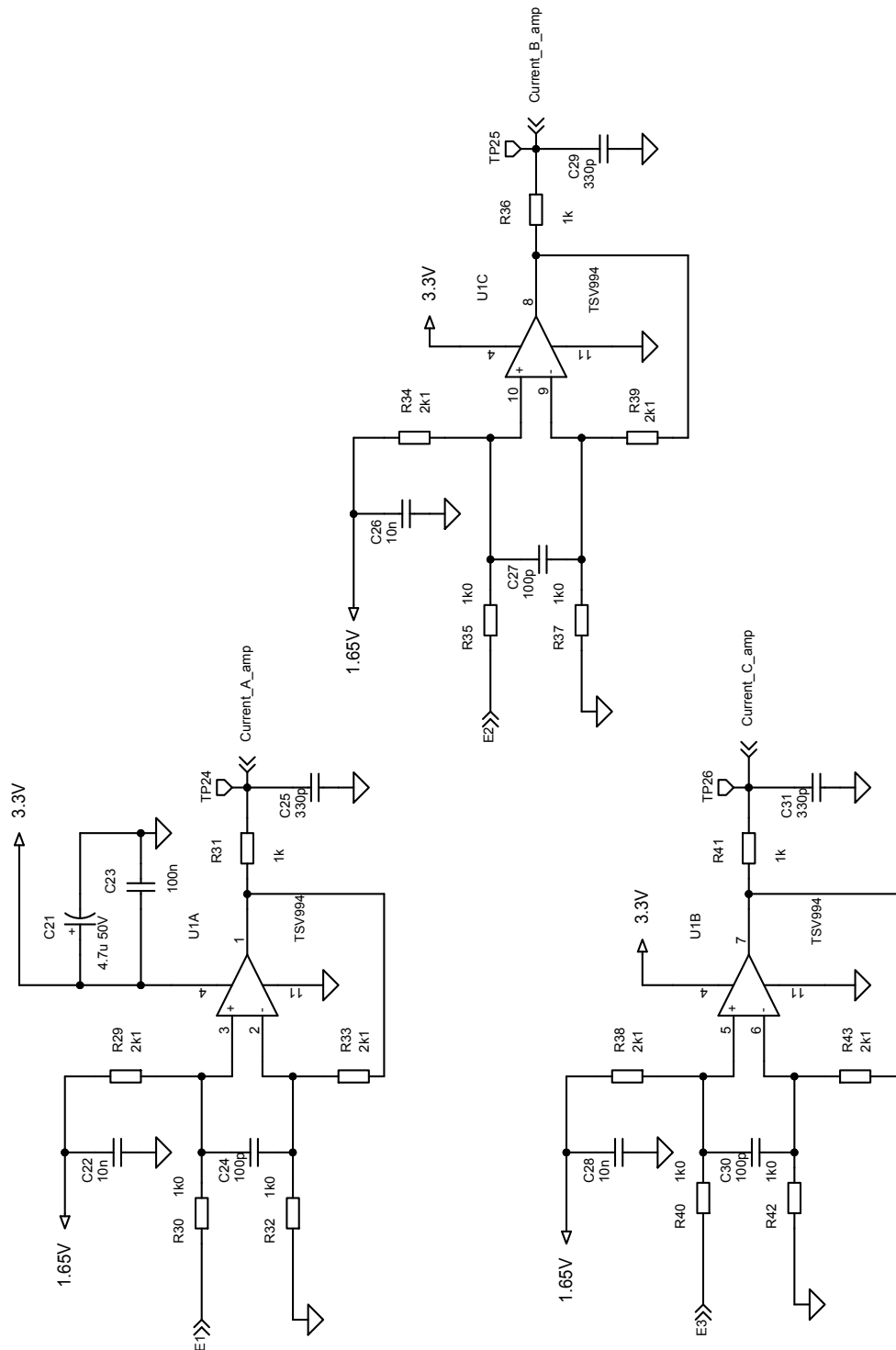

Figure 4. STEVAL-IPM15B circuit schematic (4 of 6)



**Figure 5. STEVAL-IPM15B circuit schematic (5 of 6)**

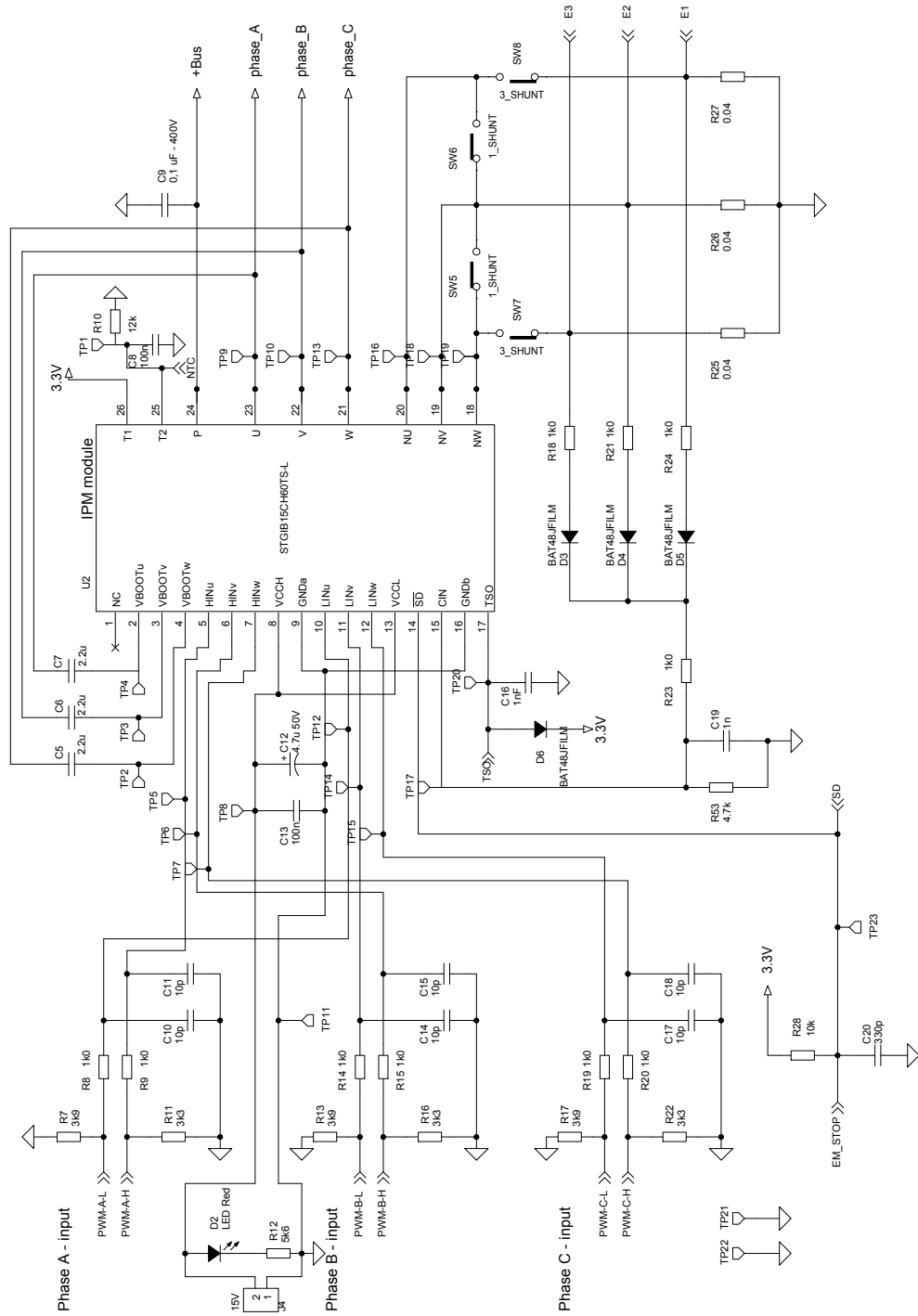
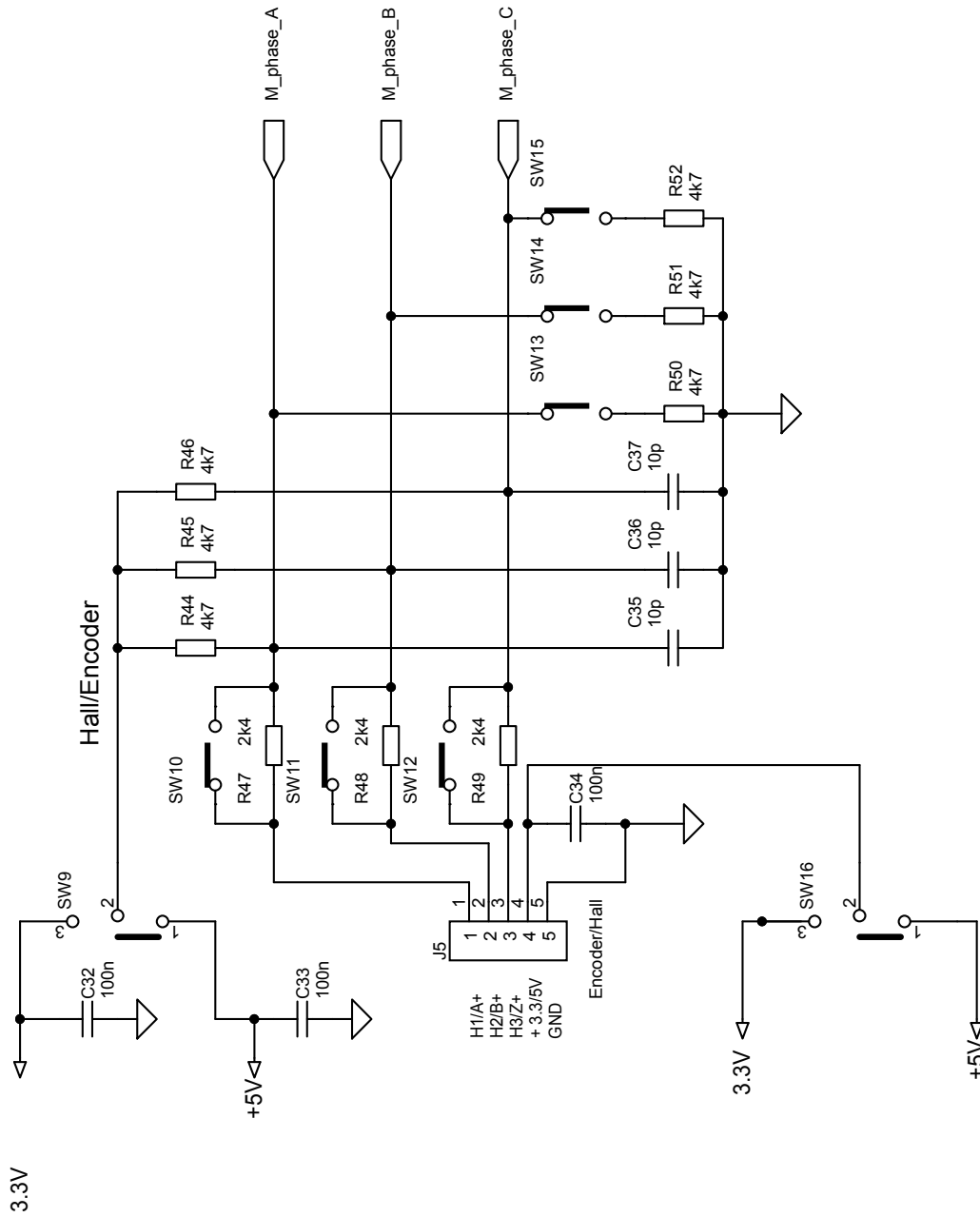

Figure 6. STEVAL-IPM15B circuit schematic (6 of 6)



## Revision history

**Table 1. Document revision history**

Date	Version	Changes
06-Nov-2015	1	Initial release.
03-Mar-2016	2	Updated: figure 1 and figure 3.
06-Apr-2018	3	Updated: title, features and figure 5.
13-Sep-2019	4	Updated: Figure 3. STEVAL-IPM15B circuit schematic (3 of 6) and Figure 4. STEVAL-IPM15B circuit schematic (4 of 6)