

1500 W motor control power board based on STIB1560DM2T-L SLLIMM™ 2nd series MOSFET IPM

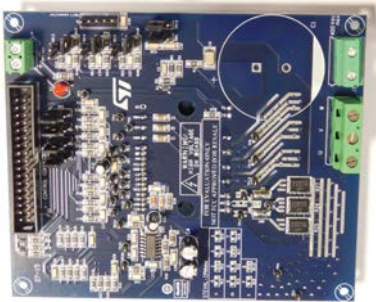

Features

- Input voltage: 125 - 400 VDC
- Nominal power: up to 1500 W
 - Allowable maximum power is related to the application conditions and cooling system
- Nominal current: up to 6 A_{rms}
- Input auxiliary voltage: up to 20 V DC
- Single- or three-shunt resistors for current sensing (with sensing network)
- Two options for current sensing: dedicated op-amps or through MCU
- Overcurrent hardware protection
- IPM temperature monitoring and protection
- Hall sensor or encoder input
- MOSFET intelligent power module:
 - SLLIMM™ 2nd series IPM (STIB1560DM2T-L - DBC package)
- Motor control connector (32-pin) to interface with ST MCU boards
- Universal conception for further evaluation with breadboard and testing pins
- Very compact size
- WEEE compliant
- RoHS compliant

Product summary	
1500 W motor control power board based on STIB1560DM2T-L SLLIMM™ 2nd series MOSFET IPM	STEVAL-IPMM15B
SLLIMM 2nd series IPM, 3-phase inverter 0.15 Ω typ., 15 A, 600 V Power MOSFET	STIB1560DM2T-L
Featured technologies	STPOWER SLLIMM MDmesh DM2
Development environments	STM32 MCSDK STSW-POWERSTUDIO
Applications	PMSM / BLDC Motor 3-phase Induction Motor (ACIM)

Description

The **STEVAL-IPMM15B** is a compact motor drive power board equipped with the SLLIMM (small low-loss intelligent molded module) 2nd series module 2nd series n-channel super junction MDmesh™ DM2 fast-recovery diode (**STIB1560DM2T-L**). It provides an affordable, easy-to-use solution for driving high power motors for a wide range of applications such as white goods, air conditioners, compressors, power fans, high-end power tools, and generally 3-phase inverters for motor drives.

The IPM itself consists of MOSFETs and a wide range of features including undervoltage lockout, smart shutdown, temperature sensing and NTC inside, and overcurrent protection.

The main characteristics of this evaluation board are its small size, minimal BOM and high efficiency. It consists of an interface circuit (BUS and V_{CC} connectors), bootstrap capacitors, snubber capacitor, hardware short-circuit protection, fault event signal and temperature monitoring. It is designed to work in single or three-shunt configuration and with two current sensing options: three dedicated op-amps on the evaluation board, or op-amps available on a connected microcontroller. A Hall/Encoder section completes the circuit.

The system is designed to achieve accurate and fast conditioning of current feedback to satisfy the typical requirements for field-oriented control (FOC).

The **STEVAL-IPMM15B** is compatible with ST control boards based on STM32 microcontrollers, providing a complete platform for motor control.

1 Schematic diagrams

Figure 1. STEVAL-IPMM15B board schematic (1 of 5)

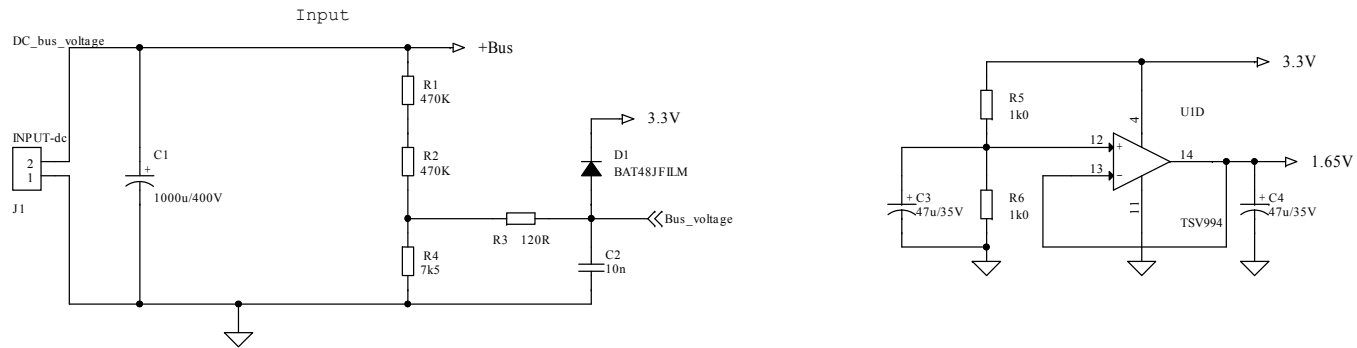

STEVAL-IPM1nmx decoder

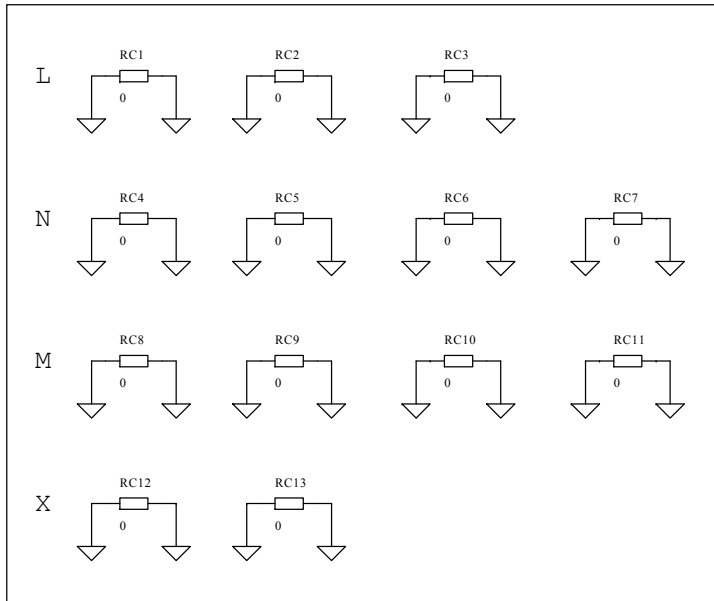

Figure 2. STEVAL-IPMM15B board schematic (2 of 5)

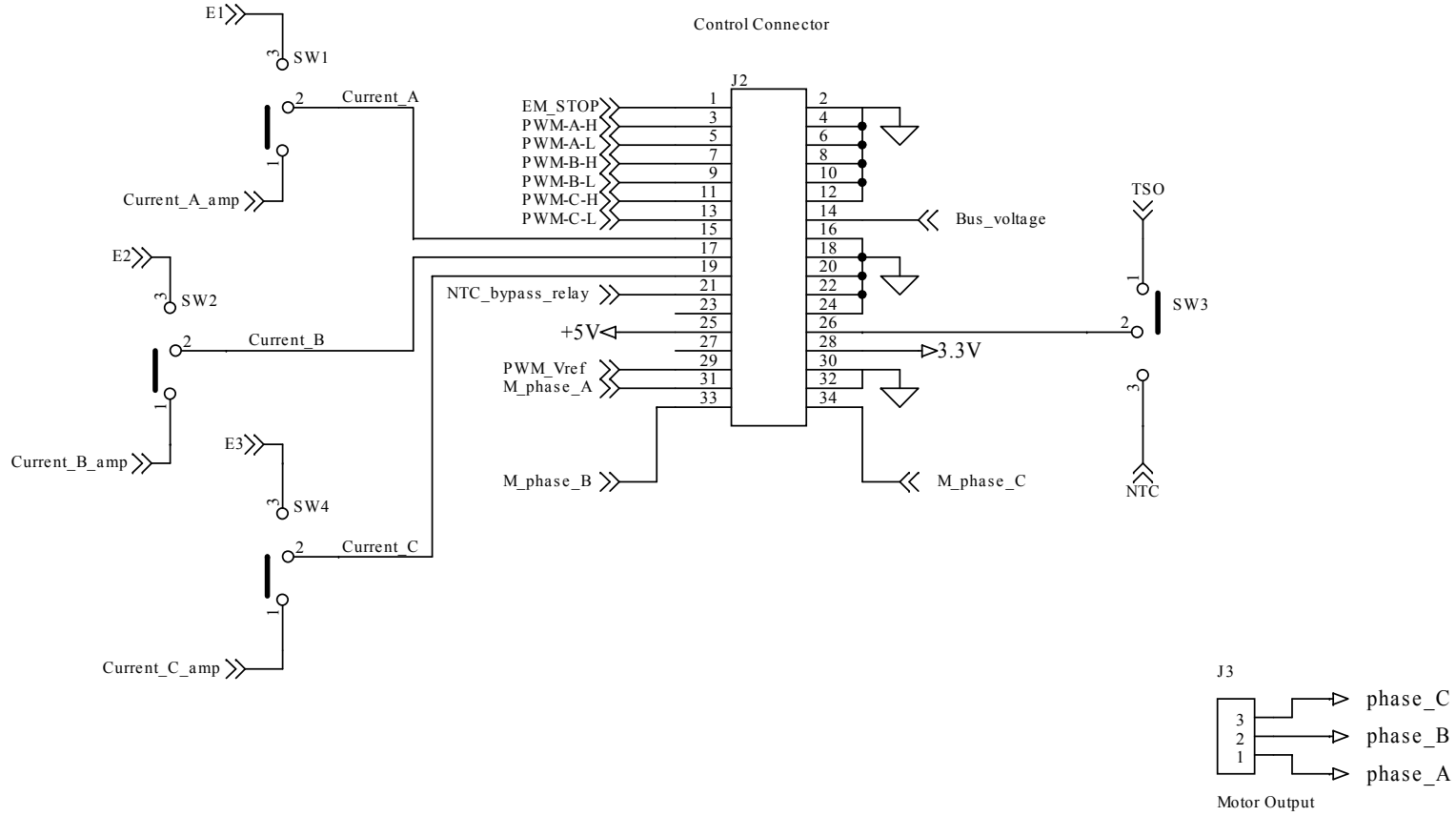

Figure 3. STEVAL-IPMM15B board schematic (3 of 5)

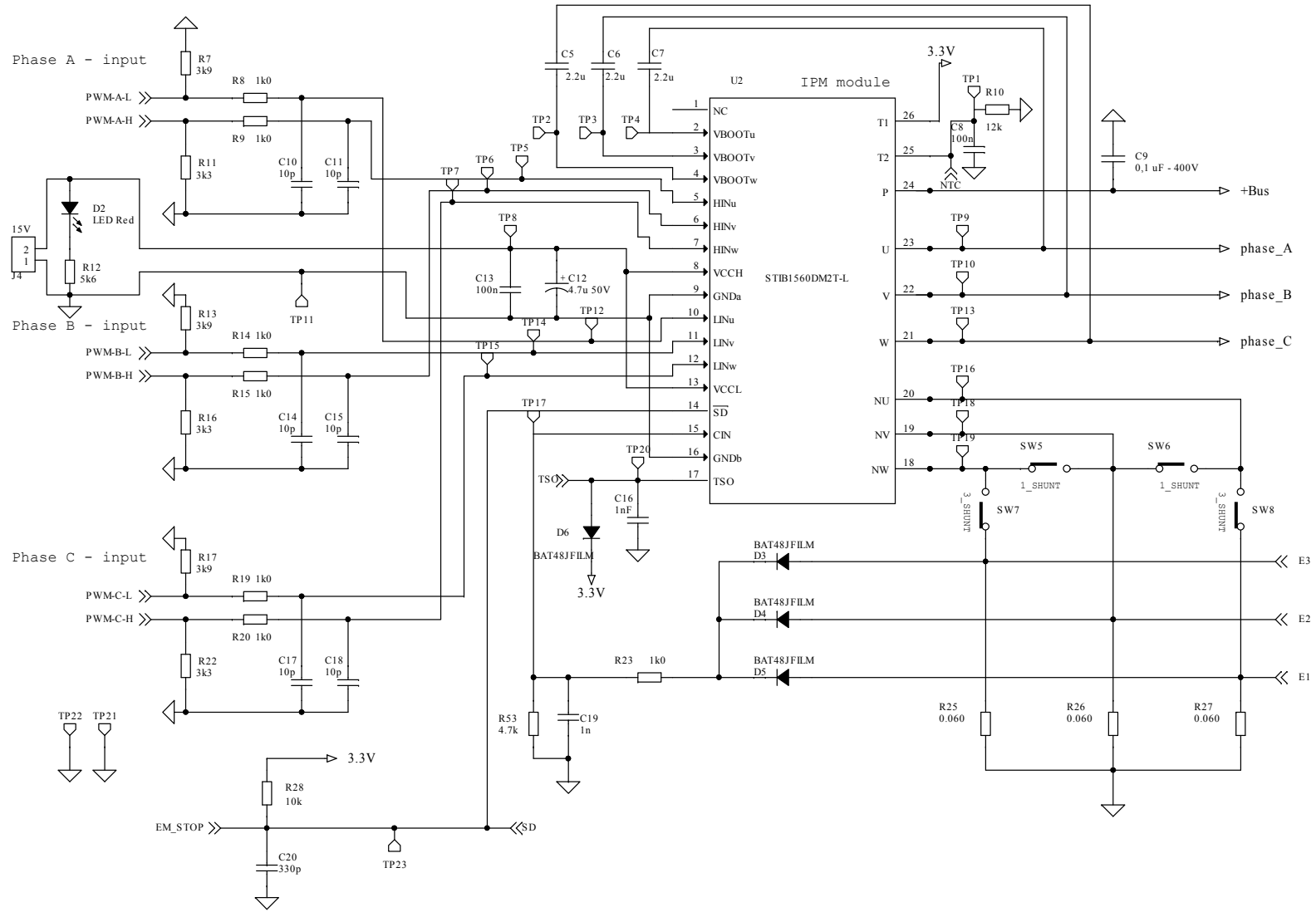

Figure 4. STEVAL-IPMM15B board schematic (4 of 5)

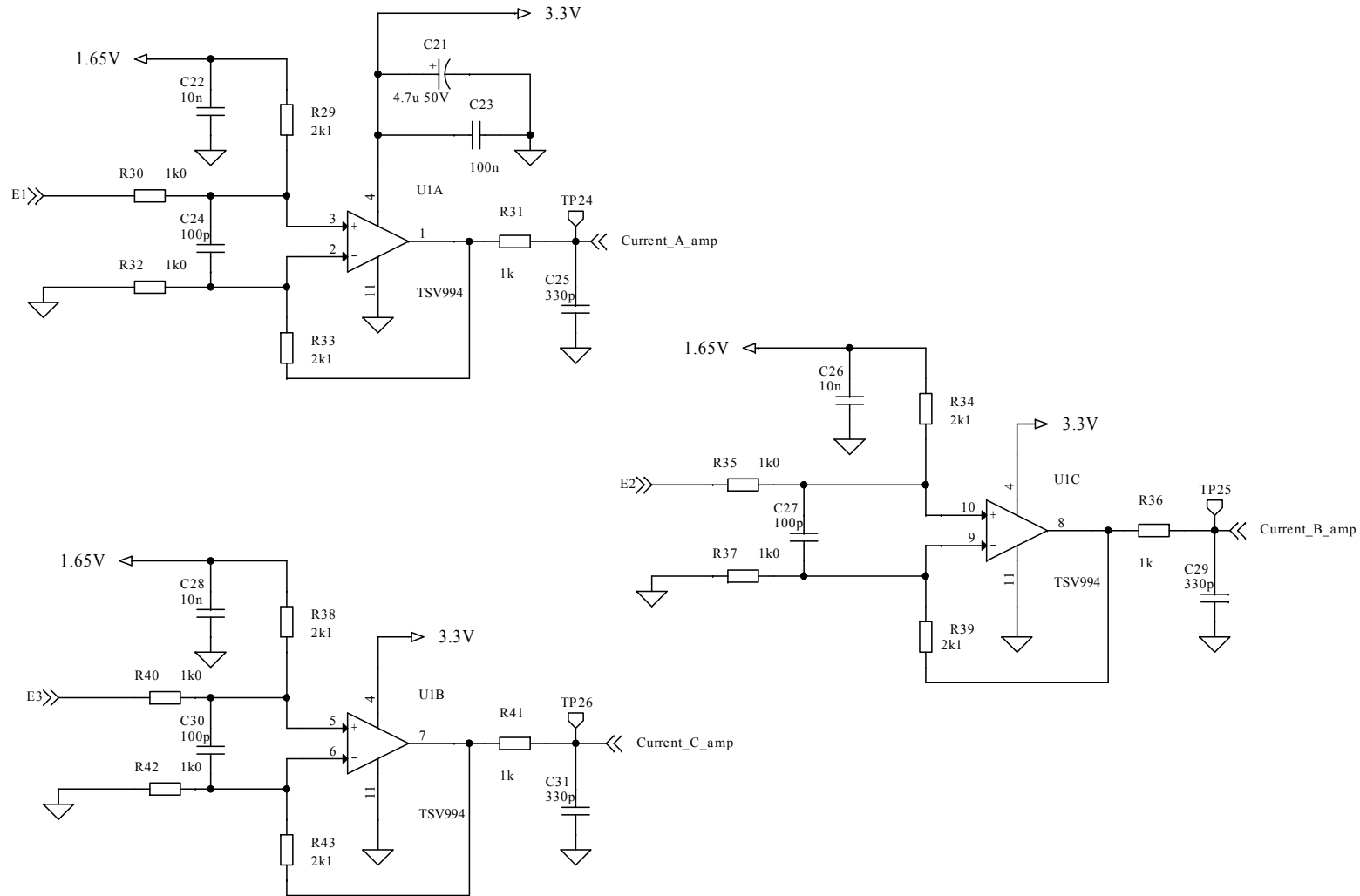
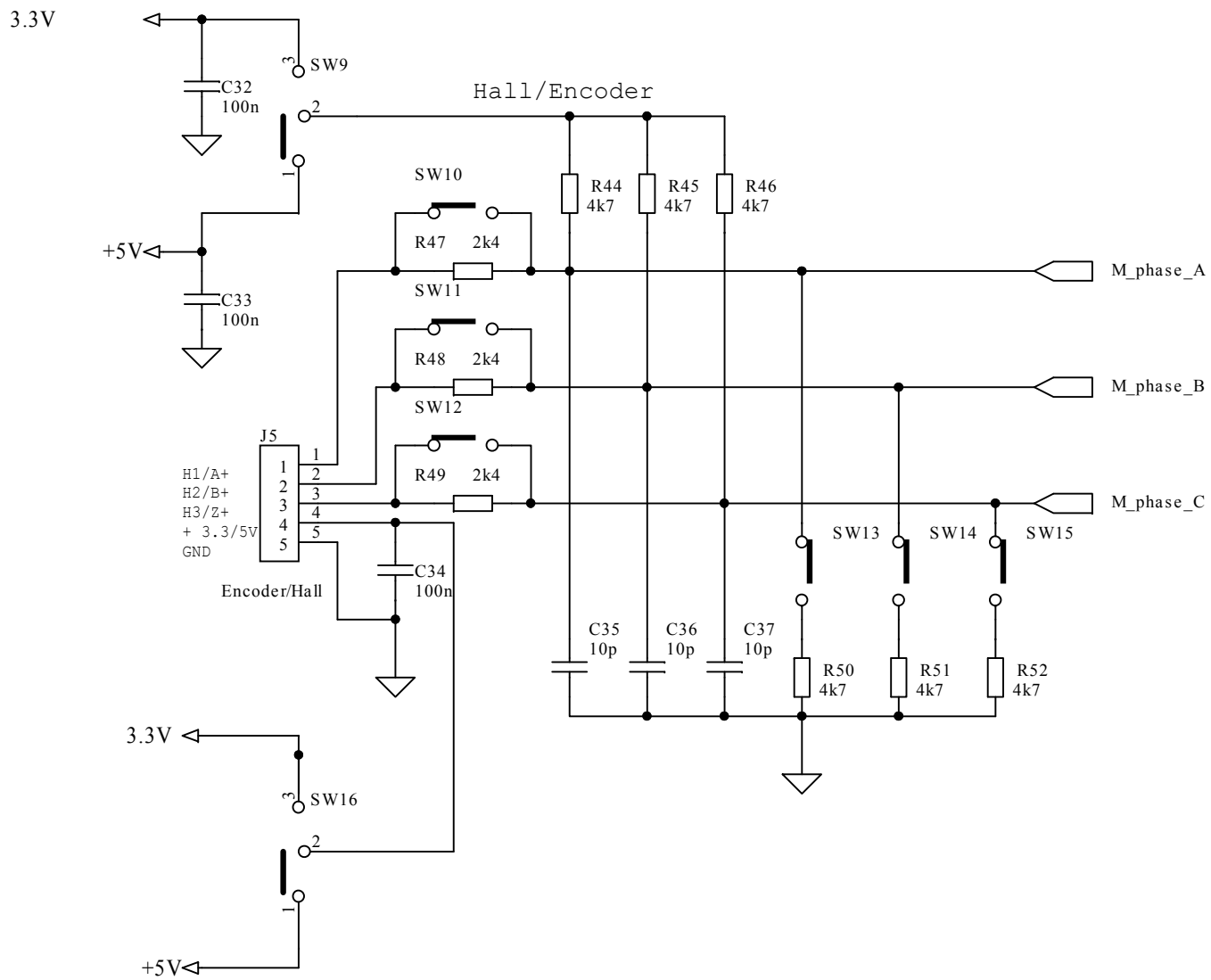

Figure 5. STEVAL-IPMM15B board schematic (5 of 5)



Revision history

Table 1. Document revision history

Date	Version	Changes
16-Apr-2020	1	Initial release.