

Motor control power board based on the SLLIMM-nano 2nd series

Data brief

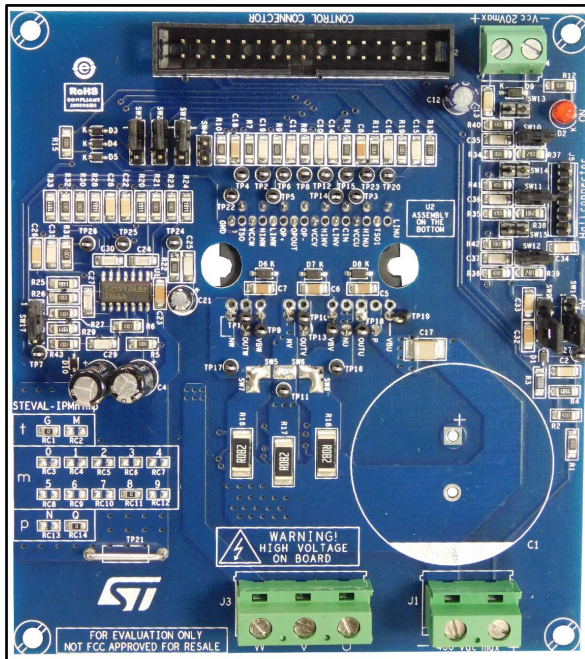

- Motor control connector (32 pins) interfacing with ST MCU boards
- Universal design for further evaluation with bread board and testing pins
- Very compact size
- RoHS compliant

Description

The STEVAL-IPMnG8Q is a compact motor drive power board based on SLLIMM™-nano (small low-loss intelligent molded module) 2nd series product (STGIPQ8C60T-HZ). It provides an affordable and easy-to-use solution for driving high power motors in a wide range of applications such as power white goods, air conditioning, compressors, power fans and 3-phase inverters for motor drives in general.

The main characteristics of this evaluation board are small size, minimal BOM and high efficiency. It features an interface circuit (BUS and V_{CC} connectors), bootstrap capacitors, snubber capacitor, hardware short-circuit protection, fault event signal and temperature monitoring. It is designed to work in single- or three-shunt configuration and with triple current sensing options: three dedicated on-board op-amps, op-amps embedded on MCU or single internal IPM op-amp. The Hall/Encoder part completes the circuit.

The system is designed to achieve accurate and fast conditioning of current feedback to satisfy the typical requirements for field oriented control (FOC).

The STEVAL-IPMnG8Q is compatible with ST's control board based on STM32, providing a complete platform for motor control.

Features

- Input voltage: from 125 to 400 V_{DC}
- Nominal power: up to 600 W
- Nominal current: up to 4.8 A_{rms}
- Input auxiliary voltage: up to 20 V_{DC}
- Single- or three-shunt resistors for current sensing (with sensing network)
- Three options for current sensing: dedicated external op-amps, internal SLLIMM-nano op-amp (single) or via MCU
- Overcurrent hardware protection
- IPM temperature monitoring and protection
- Hall sensor or encoder input
- IGBT intelligent power module:
 - 2nd series SLLIMM-nano IPM (STGIPQ8C60T-HZ – full molded package)

Schematic diagrams

Figure 1: STEVAL-IPMnG8Q circuit schematic (1 of 5)

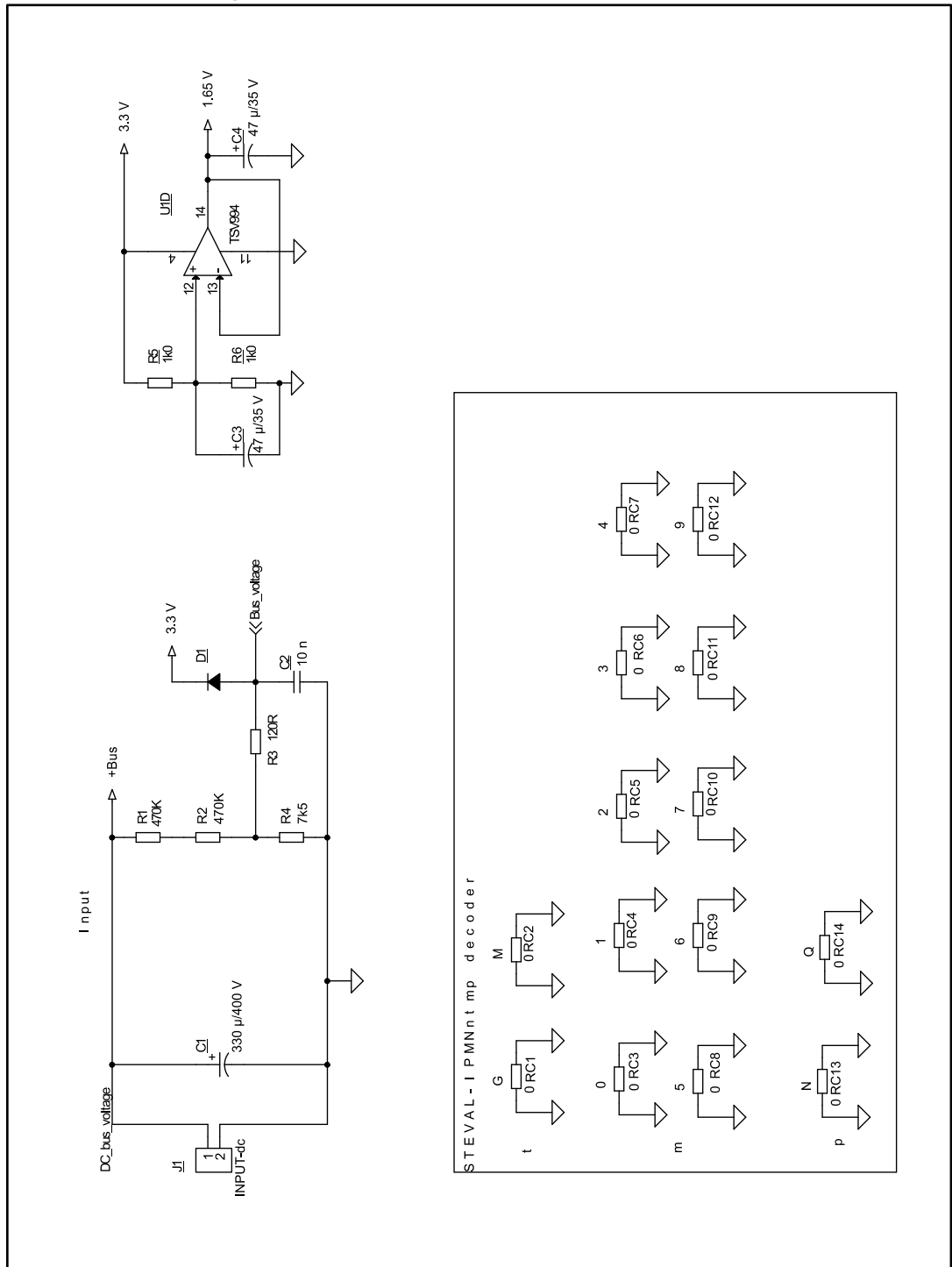

Figure 2: STEVAL-IPMNG8Q circuit schematic (2 of 5)

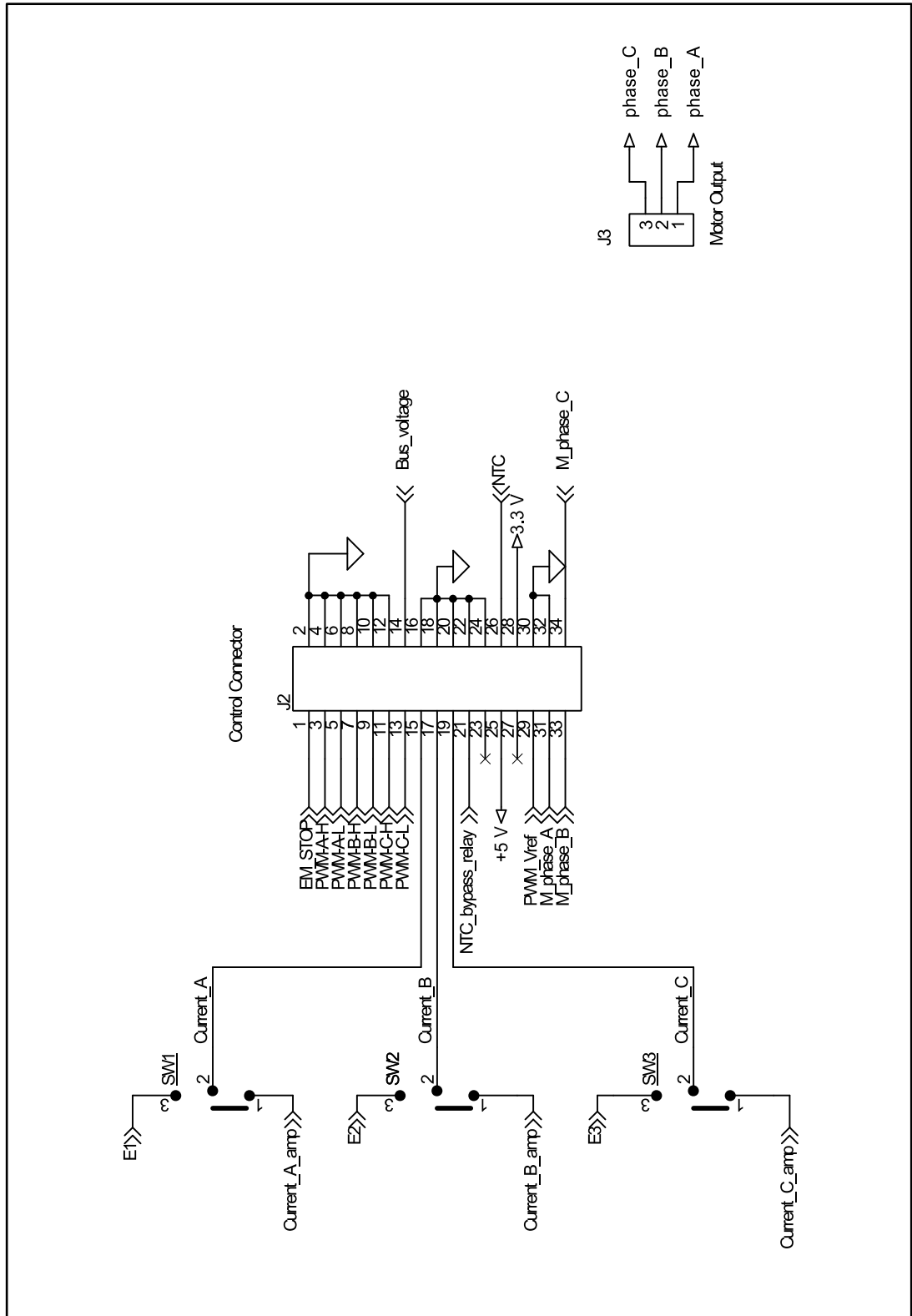

Figure 3: STEVAL-IPMnG8Q circuit schematic (3 of 5)

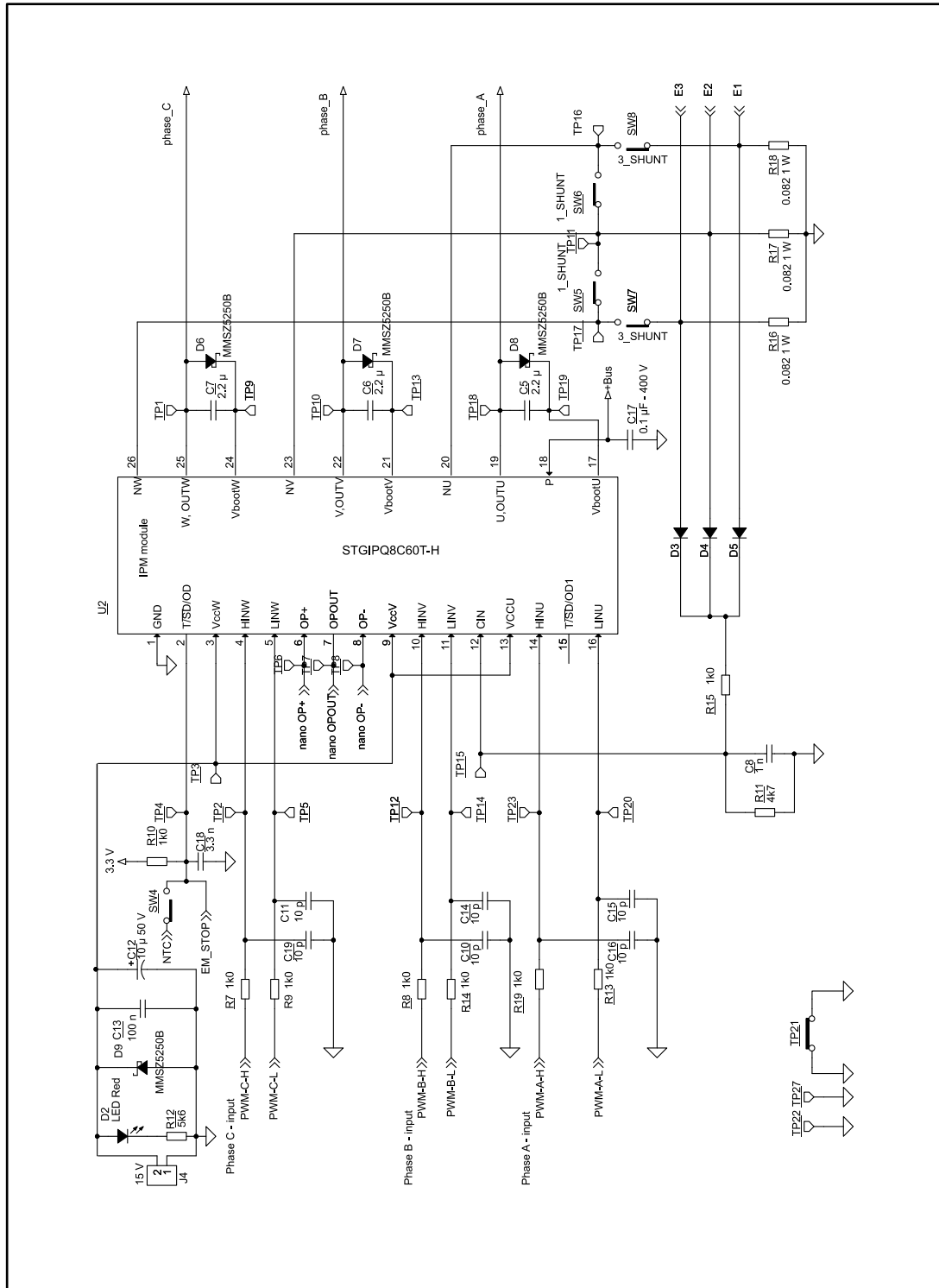

Figure 4: STEVAL-IPMnG8Q circuit schematic (4 of 5)

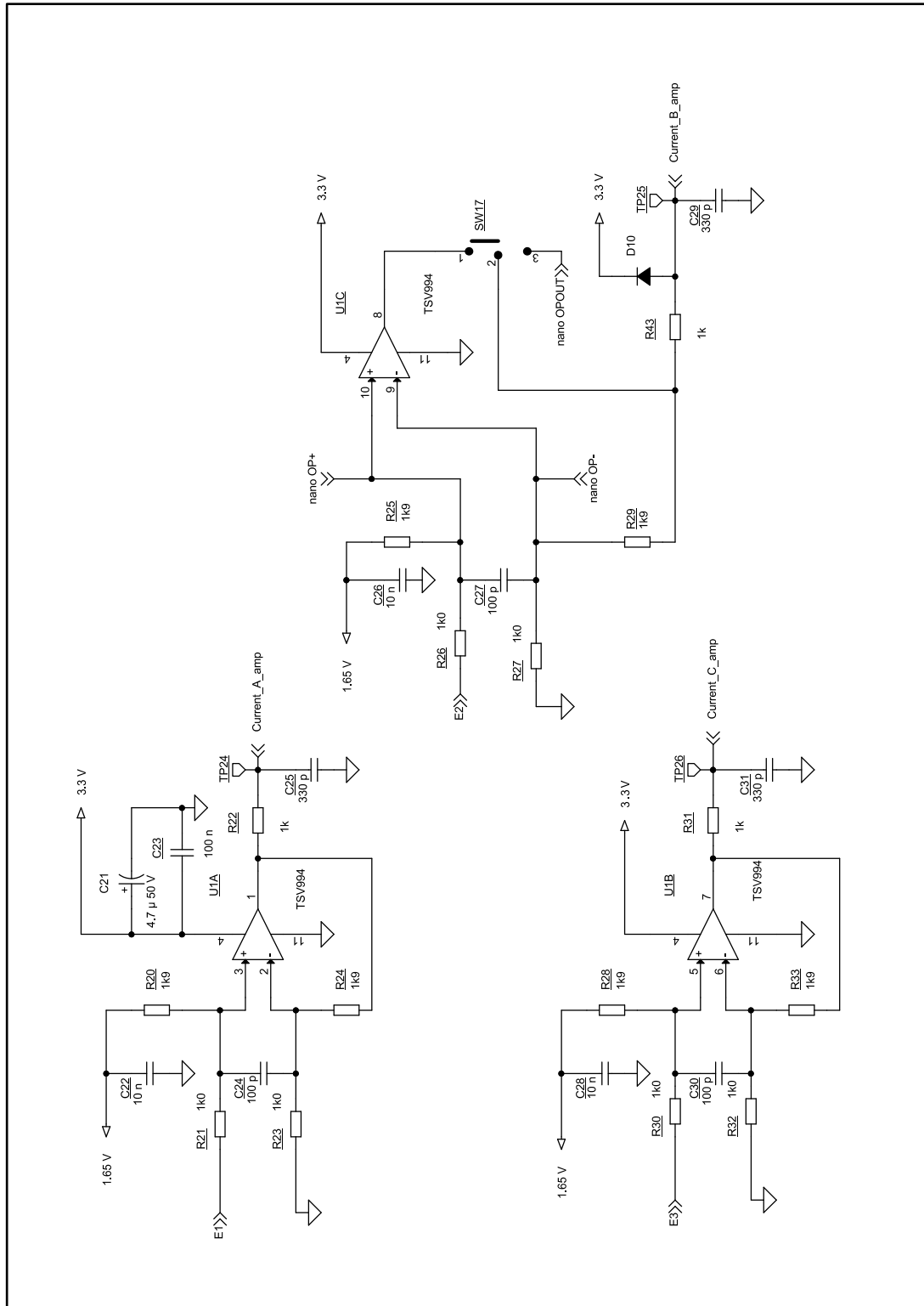
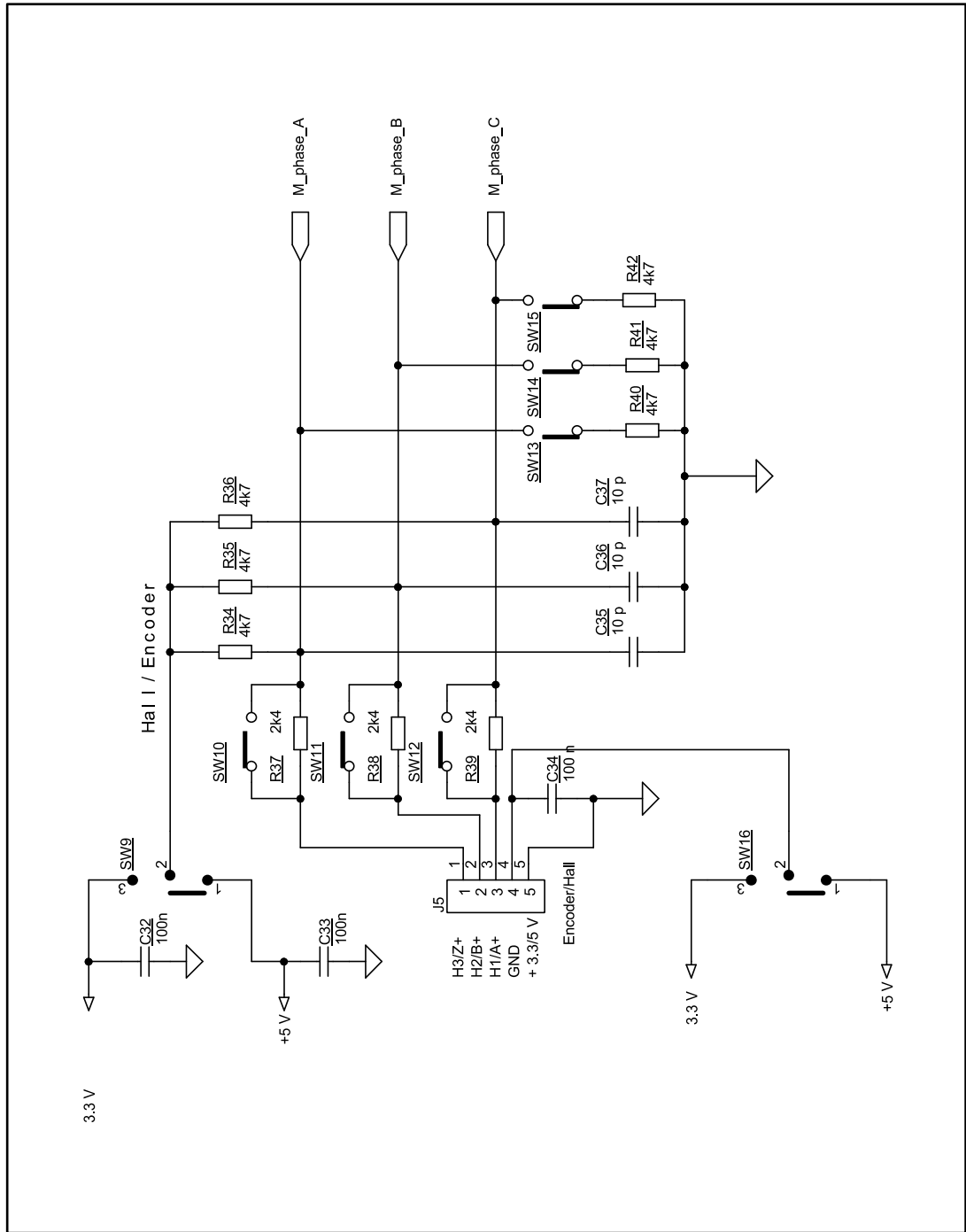

Figure 5: STEVAL-IPMnG8Q circuit schematic (5 of 5)



Revision history

Table 1: Document revision history

Date	Version	Changes
12-Sep-2017	1	Initial release.