

60 W motor control power board based on STIPNS1M50T-H SLLIMM™-nano SMD IPM MOSFET

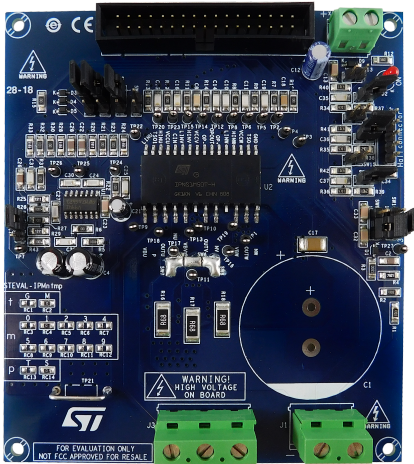

Features

- Input voltage: from 125 to 400 V_{DC}
- Nominal power: up to 60 W
- Nominal current: up to 0.6 A
- Input auxiliary voltage: up to 20 V_{DC}
- Single- or three-shunt resistors for current sensing (with sensing network)
- Three options for current sensing: dedicated external op-amps, internal SLLIMM-nano SMD op-amp (single) or via MCU
- Overcurrent hardware protection
- IPM temperature monitoring and protection
- Hall sensor or encoder input
- MOSFETs intelligent power module:
 - SLLIMM-nano IPM (STIPNS1M50T-H) - SMD package
- Motor control connector (32 pins) interfacing with ST MCU boards
- Universal design for further evaluation with breadboard and testing pins
- Very compact size
- WEEE compliant
- RoHS compliant

Description

The **STEVAL-IPMnM1S** is a compact motor drive power board based on SLLIMM-nano SMD (small low-loss intelligent molded module) product (**STIPNS1M50T-H**). It provides an affordable and easy-to-use solution for driving high power motors in a wide range of applications such as power white goods, air conditioning, compressors, power fans and 3-phase inverters for motor drives in general.

The IPM itself consists of six MOSFETs, three high voltage half-bridge gate driver ICs and a wide range of features like undervoltage lockout, smart shutdown, internal temperature sensor and NTC, overcurrent protection and internal op-amp.

The main characteristics of this evaluation board are small size, minimal BOM and high efficiency. It features an interface circuit (BUS and VCC connectors), bootstrap capacitors, snubber capacitor, hardware short-circuit protection, fault event signal and temperature monitoring. It is designed to work in single- or three-shunt configuration and with triple current sensing options: three dedicated on-board op-amps, op-amps embedded on MCU or single internal IPM op-amp. The Hall/Encoder part completes the circuit.

The system is designed to achieve accurate and fast conditioning of current feedback to satisfy the typical requirements for field oriented control (FOC).

The STEVAL-IPMnM1S is compatible with ST's control board based on STM32, providing a complete platform for motor control.

Product summary	
Motor control power board based on the SLLIMM-nano in SMD package	STEVAL-IPMnM1S
SLLIMM-nano SMD small low-loss intelligent molded module IPM, 3-phase inverter, 1 A, 3.6 Ohm max., 500 V MOSFET	STIPNS1M50T-H

1 Schematic diagrams

Figure 2. STEVAL-IPMnM1S - circuit schematic (1 of 5)

Figure 3. STEVAL-IPMnM1S - circuit schematic (2 of 5)

Figure 5. STEVAL-IPMnM1S - circuit schematic (4 of 5)

Figure 6. STEVAL-IPMnM1S - circuit schematic (5 of 5)

Revision history

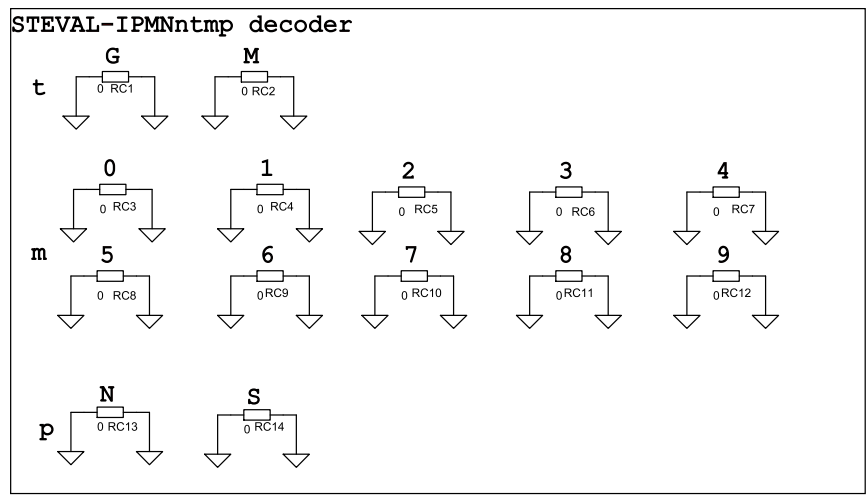
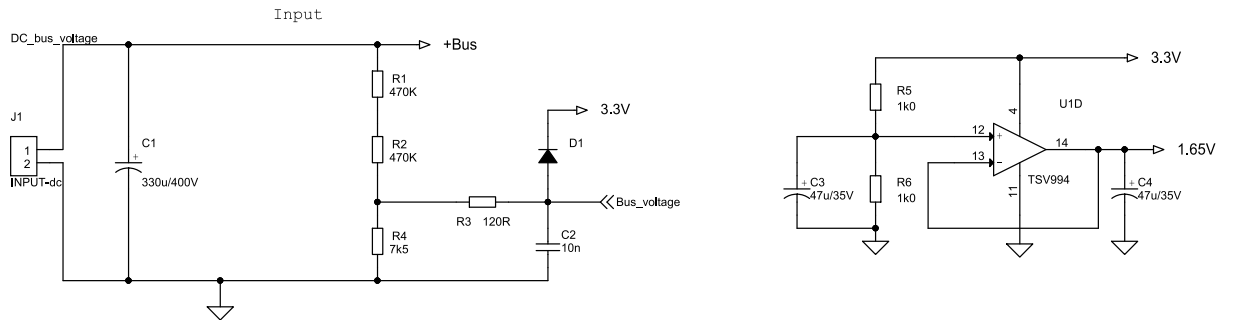
Table 1. Document revision history

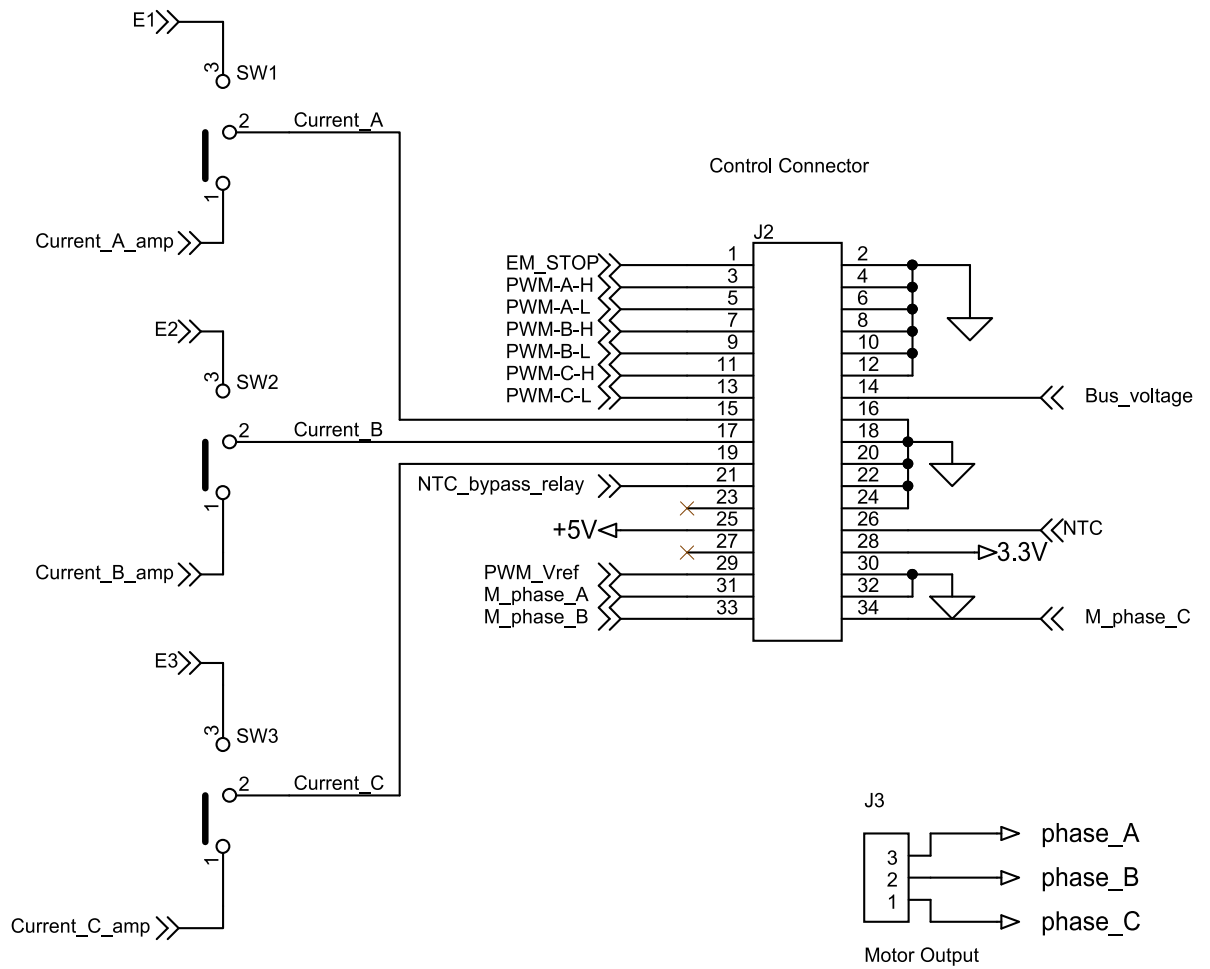
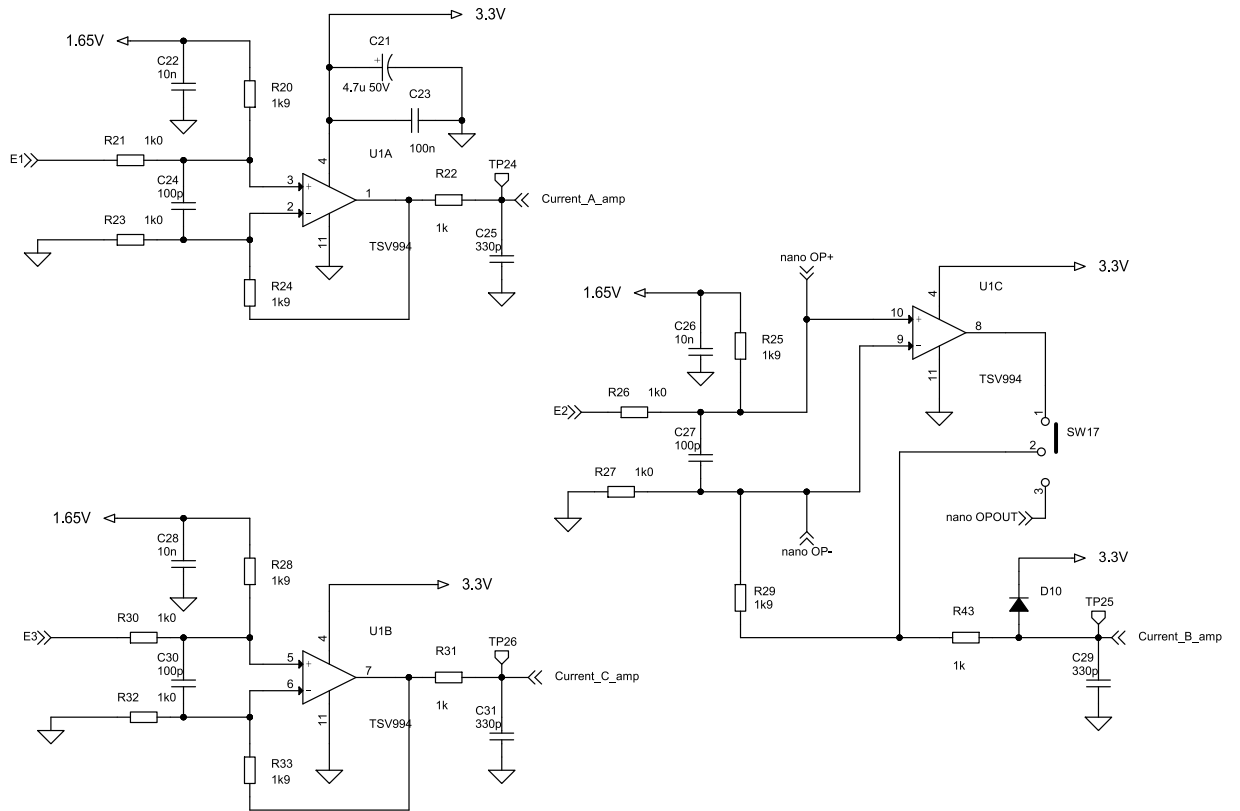
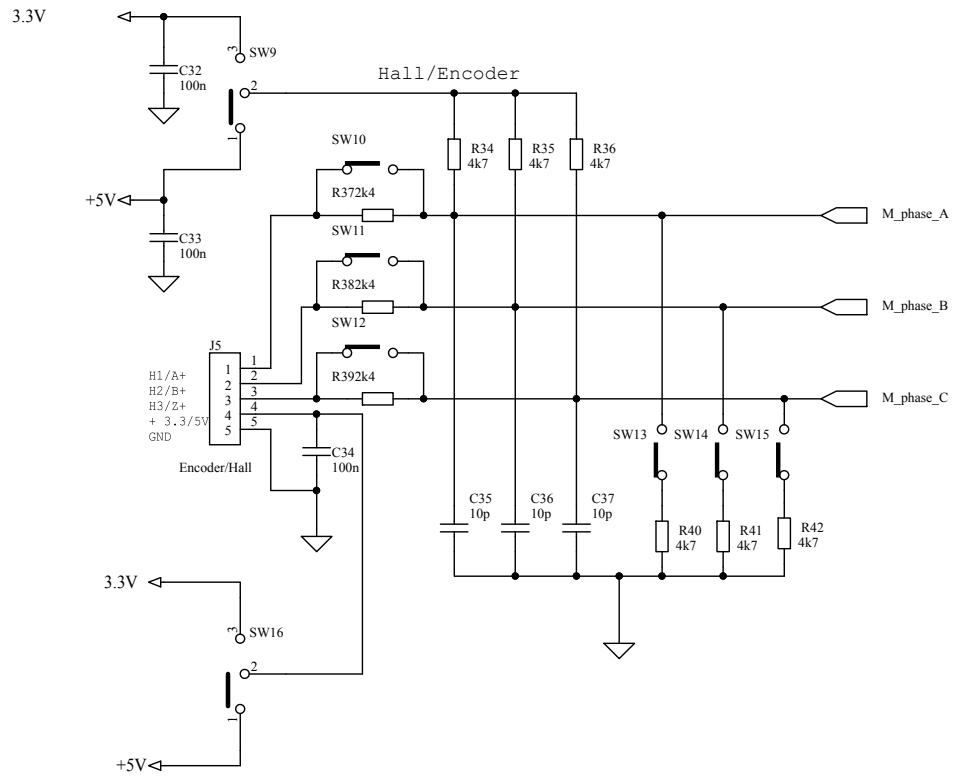
Date	Version	Changes
10-Aug-2018	1	Initial release.
21-Sep-2018	2	Update Section features and Section 1 schematic